

The
CASHFLOW 560
REFERENCE SERIES
CHANGE GIVER
APPLICATIONS DESIGN
GUIDE

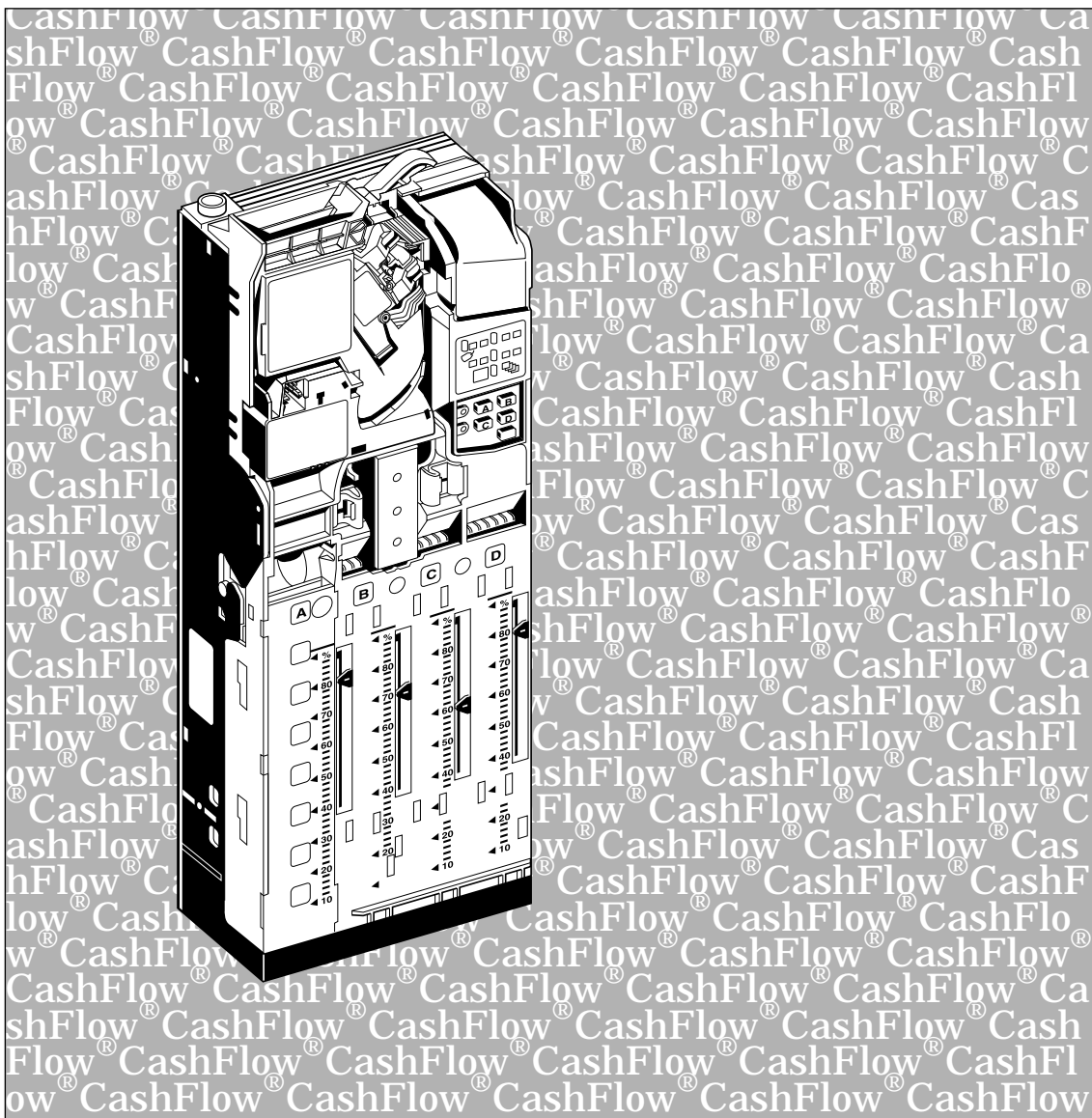

CashFlow[®] 560 change giver Applications Design Guide

Published by :

MEI

Internet: <http://www.meigroup.com>

For information on translations in your country, please write to the Technical Communications Manager at the above address.

CashFlow[®] 560 change giver Applications Design Guide

©, MEI UK International Ltd., 1996.

All rights reserved.

Except as permitted under the relevant local legislation, no part of this publication may be copied, transmitted, transcribed, or distributed in any form or by any means, or stored in a database or retrieval system, or translated into any language (natural or computer), without the prior written permission of MEI.

MEI[®], CashFlow[®] and the MEI device are registered trademarks.

©, MEI., 1996.

MEI reserves the right to change the product or the product specifications at any time. While every effort has been made to ensure that the information in this publication is accurate, MEI disclaims any liability for any direct or indirect losses (howsoever caused) arising out of use or reliance on this information.

This document does not necessarily imply product availability.

Part Number :

142922044

This Edition (March 1996)

Printed in the United Kingdom.

TABLE OF CONTENTS

SAFETY	1
OVERVIEW	2
PRODUCT OPERATION	5
GENERAL	5
ELECTRO-MECHANICAL PRODUCT	5
SERIAL INTERFACE PRODUCTS	5
ACCEPTOR MODULE	6
ACCEPT GATE MODULE	7
SEPARATOR	7
CONTROL BOARD	7
SPINE	7
TRANSFORMER ASSEMBLY	8
KEYPAD	8
DISPENSER	8
COIN STORAGE CASSETTE	8
Tube Combinations	9
Exact Change Equation	10
Using Exact Change Inhibit	12
COIN ACCEPTANCE, ROUTING & RETURN	13
COIN ACCEPTANCE	13
Global Coin Inhibit	14
COIN ROUTING	14
CHANGE PAYBACK	15
Use of Tubes	15
Best Change Calculation	15
TUBE SENSOR USAGE	16
Full sensors	16
Coin cassette removal detection	17
Full sensor error detection	18
Coin count re-calibration	18
Low sensor error detection	18

Coin count re-calibration.....	19
Home sensors.....	20
PRODUCT INTERFACES	21
ELECTRICAL INTERFACES.....	22
ELECTRO MECHANICAL INTERFACE	25
EXACT CHANGE OUTPUT.....	25
CREDIT RELAY DRIVE	25
SAFETY LINE	25
PRICE LINE COMMON	25
PRICE LINE OUTPUTS.....	25
MACHINE INTERFACE	26
SINGLE / MULTI VEND	27
SENSE INPUT TIMING	27
VEND START	27
VEND FINISHED	28
BLOCKER RESET.....	28
DELAYED BLOCKER RESET	29
BLOCKER HOLD RESET.....	30
ESCROW ACCEPT	31
PRICE SENSE / BLOCKER / ESCROW ACCEPT / VEND START/ INHIBIT INPUTS.....	32
EXTERNAL CREDIT DISPLAY	33
DISPLAYING CREDIT	33
CANCELLING CREDIT.....	33
DISPLAYING VEND PRICE.....	34
DISPLAYING PRICE TEACH CREDIT	34
DISPLAYING FLOAT VALUE.....	34
POWER ON INDICATOR.....	34
DISPLAYING TUBE VALUE	34
VOLTAGE RANGES	35
POWER CONSUMPTION / RATING	35
TERMINAL CONNECTOR.....	35
MAN MACHINE INTERFACES	36
KEYPAD.....	36
LED Usage	37
Manual Coin Dispense.....	37
Automatic Tube Float (Float Up).....	38

Float Down Mode.....	39
Resetting Tube Counts.....	39
Price Teach	39
Homing the Dispensers	40
Displaying Tube Value.....	40
INTERNAL DIAGNOSTICS & ERROR HANDLING	41
HOST MACHINE PROBLEMS	41
Host Inhibited.....	41
Removal of Blocker.....	41
Blocker Return.....	42
Cashbox Full.....	42
Bad Replies Received	42
No Response	43
COIN HANDLING PROBLEMS	43
Full Sensor Failure.....	43
Post Gate Strobe (PGS) Failure	43
Tube Cassette Removal	43
Home Sensor Failure.....	44
Motor Failure / Jam.....	44
ON-BOARD EEPROM PROBLEMS	44
Incorrect Configuration vsn. No.	44
EEPROM Corruption	45
Write Timeout	45
AUDIT FEM PROBLEMS.....	46
Audit not initialised.....	46
Audit FEM corrupt.....	46
Audit removed	46
HOST INTELLIGENT INTERFACE(HI2) ERRORS ...	46
HI2 Error	46
MISCELLANEOUS ERRORS.....	47
Acceptor Initialising Error.....	47
VIA MEI[®] ROUTE ALPHA 250 TERMINAL.....	48
KEY FUNCTIONS.....	49
USING THE TERMINAL	50
VISUAL AUDIT	52
Visual Audit Interrogation.....	52
DIAGNOSING TERMINAL PROBLEMS	64
Testing the Terminal.....	65

ENVIRONMENTAL PERFORMANCE	66
TEMPERATURE RANGE	66
HUMIDITY	66
VIBRATION	66
INSTALLATION	66
TRANSPORTATION	67
LIQUIDS	67
VOLTAGE	68
VOLTAGE TRANSIENTS	68
SAFETY CLASSIFICATIONS	69
CLASSIFICATION	69
PARTITIONS	69
SAFETY INSULATION	70
ENERGY STORAGE	70
FLAMMABILITY	70
ELECTRO-MECHANICAL AND MAINS INPUT RATINGS	71
MECHANICAL PARTS	71
COMPATIBILITY	72
BILL VALIDATOR INTERFACE	74
MEI OFFICES	78
INDEX	79
APPENDIX	84
INTERFACE DRAWING	84

SAFETY

International & National Standards Conformance

When installed and operated according to the instructions for the particular unit, CashFlow[®] 560 products are designed to meet the applicable Safety and Electro Mechanical Conformance standards for any country in which they are used.

CashFlow[®] 560 products are of class II construction. No safety earth connection is necessary or provided.

Dangerous Environments

Do not operate in the presence of flammable gases, fumes or water.

Disposal of Product

Do not dispose of any parts of this product by incineration.

Rated Operating Voltage

The rated voltage is indicated on a clear see through label above the change giver keypad.

Always operate the change giver from the type of power source indicated on the label.

Warning: before removing or replacing modules
SWITCH OFF or ISOLATE the ELECTRICITY SUPPLY to the host machine

THIS MANUAL IS PROVIDED FOR USE ONLY BY PERSONNEL TRAINED TO UNDERTAKE ELECTRICAL INSTALLATION

OVERVIEW

The CashFlow[®] 560 range of changegivers have been designed to address a wide range of market needs and are compatible with the majority of modern vending machines. They are plug compatible replacements for the previous MS1600, ME1600 and ME1900 series of changegivers. The flexible approach allows easy matching of modules for all types of applications. They are designed to work with a wide range of coinsets and can be upgraded to accept new coins. There are four change tubes and field selection of the coins to be stored in them is possible. On the front of the changegiver is a keypad which is used to dispense coins and re-configure some aspects of the changer. All CashFlow[®] 560 changegivers are made up of several modules;

- Control board
- Spine
- Transformer
- Keypad
- Dispenser
- Acceptor
- Separator
- Coin Storage Cassette

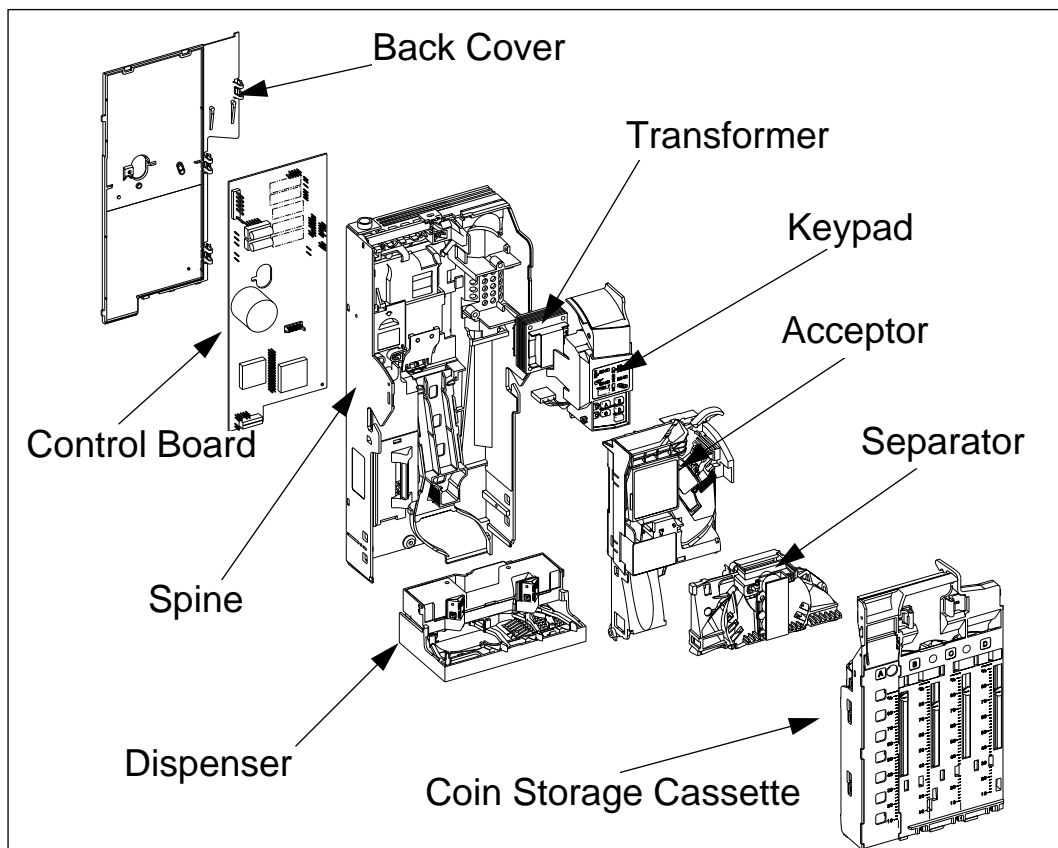

Exploded View of the CashFlow Changer

The basic functionality of all change givers is to:

- Accept payment
- Signal the payment available to the machine (credit output)
- Monitor the product request inputs (sense inputs)
- Return un-used change
- Monitor the machine inhibited condition (blocker)

The following function is appropriate for electro-mechanical 4-price product only:

- Enable the appropriate price line output (if the vend is authorised)

The following functions are appropriate for electro-mechanical 4-price, Executive and BDV product only:

- Deduct the vend price from the credit available
- Indicate to the host machine the exact change condition

The product options currently available are;

- CashFlow[®] 560 - 4 price - A four price electro-mechanical change giver

N.B. A credit display for use with the above variant can be provided.

- CashFlow[®] 560 - Executive - change giver with an electronic Protocol A serial interface
- CashFlow[®] 560 - BDV - change giver with an electronic BDV serial interface
- CashFlow[®] 560 - MDB - change giver with an electronic MDB serial interface

CashFlow[®] 560 change giver Applications Design Guide

With the use of the MEI[®] Route Alpha 250 terminal you can also re-configure certain operational aspects of the change giver. This includes inhibiting coins, changing from single to multi vend etc..

The CashFlow[®] 560 electro-mechanical and Executive products can be supplied with an audit function extension module (FEM) fitted, or this can be supplied for fitting at a later date.

The FEM allows for reports to be supplied either via a hand-held MEI[®] Audit 920 printer, or down-loaded via a terminal to a P.C..

These reports can include:

- Value of cash manually filled
- Value of cash retained in the change giver
- Value of cash sales
- Value of token sales
- Value of cash taken by the machine
- Value of cash to cashbox
- Value of cash dispensed as change

The process of obtaining data is detailed in the section of this book concerned with the MEI[®] Route Alpha 250 terminal.

For further details of audit installation please refer to the MEI[®] Audit 900 Installation Guide, part number 143451999.

Additional information on the audit FEM and the MEI[®] Audit 920 printer can be obtained from your MEI regional office.

PRODUCT OPERATION

GENERAL

ELECTRO-MECHANICAL PRODUCT

When a coin is entered through the electro-mechanical change giver there are several conditions that are electronically checked.

After coins have been accepted and a product selection button is pressed a sense current flows through the change givers sense circuit. The sense current is not sufficient to energise the relay, but enough for the change giver to detect. When the change giver detects that a product selection button has been pressed the change giver looks up the price associated with the selection. If sufficient credit exists the change giver turns the price line output on. This disconnects the safety line from price line common and connects the price line output to price line common. The vend motor relay within the vending machine is then energised, turning the vend motor on and closing a switch across the selection button.

When the vend cycle begins the blocker signal indicates to the change giver that a vend has started. The price of the vend is deducted and the change giver waits for the vend to finish. The price line output is turned off when the change giver considers the vend to have finished.

Unused credit may be returned after the vend has finished either automatically if in single vend mode, or by customer demand if it is in multi vend mode, or after a pre-determined time in multi-vend option setting, depending on how the change giver has been set up.

SERIAL INTERFACE PRODUCTS

Dependent on which version of product is being used , when coins or cashless card are inserted the value involved will be shown on the display, if used. The host machine's VMC communicates all functions as required with the change giver and any other peripherals, such as an audit unit or cashless payment system, that are being used.

The VMC in the host machine produces signals to the change giver (excluding MDB product) indicating when a vend is to be made, and the value of the vend required. The change giver will then ascertain if sufficient credit is available to cover the cost of the vend. If the change giver is set to "No Overpay" it will confirm that any remaining coin credit that would result from the vend can be returned before authorising the vend.

CashFlow[®] 560 change giver Applications Design Guide

If the vend is allowed the cost will be deducted from the credit prior to authorising the VMC to start the vend. Should the vend fail, this credit will be re-instated.

ACCEPTOR MODULE

There are some functions of the acceptor module which are common across the whole CashFlow[®] product range. These include coin discrimination, control and communication.

When a coin is put through the acceptor module it's validity is determined by measuring certain parameters. It also looks at the coin type status to define whether the payment is a valid coin or token, or an invalid coin. Finally, the inhibit status is checked. If the coin is not inhibited, then it will be accepted, the accept gate opened, and the coin routed to either a tube or cashbox. The acceptor module is made up of the discriminator, back cover and the accept gate.

The discriminator comprises a flight deck and lid which together form the coin control and flight path. On the inside of the flight deck lid there is a mechanical device incorporated near the coin entry point. This device is known as the coin deflector and is used to bring coins under control as they enter the product

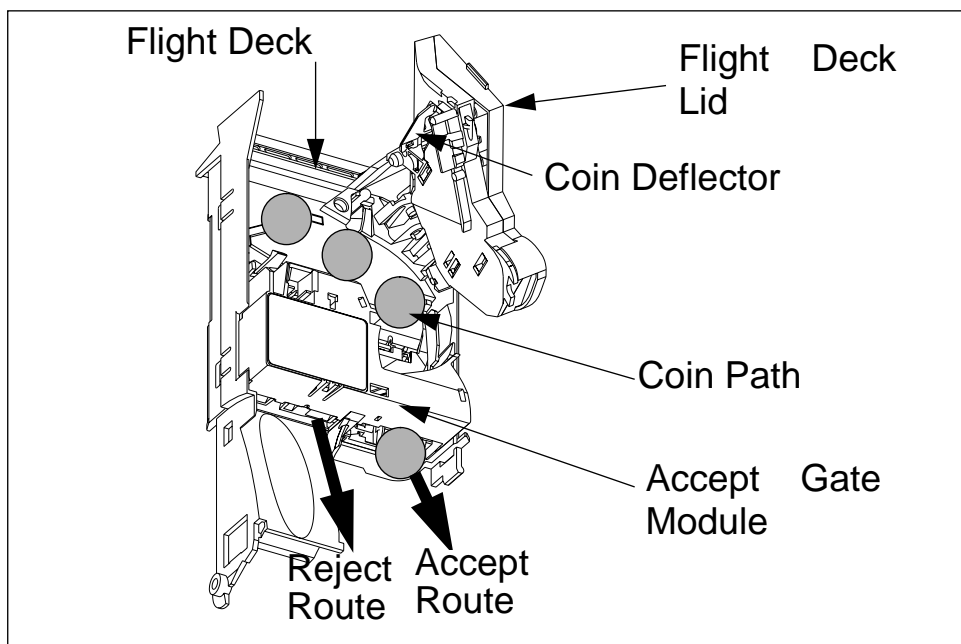

Acceptor Module

A hinge at the top right hand side of the flight deck allows coupling of the lid via an intermediate component, known as the lid arm. This allows the lid to locate accurately to the flight deck independently of the hinge. The lid also maintains a parallel coin throat by being

spaced from the deck on three bosses which locate the lid squarely to the deck.

The design of the lid arm hinge area allows the lid to open to 180 degrees relative to the deck. The opening is restricted to just over 100 degrees by the back cover to prevent the lid possibly fouling other parts.

The action of the hinge spring allows the lid to remain open when past about 100 deg. and will snap shut when closed to about 60 degrees although the lid will need to be pressed to ensure that it is correctly seated against the deck. The acceptor module connects to the control board via a 10 way ribbon cable.

On the front of the acceptor module there is a six way socket. This is for use with a MEI[®] Route Alpha 250 terminal. The terminal is hand held and, when connected to the acceptor, allows some of the operational aspects of the change giver to be altered.

ACCEPT GATE MODULE

The accept gate module contains a solenoid operated gate, optical coin strobes and coin routing components. Coins that are correctly discriminated are routed to the accept exit by energising the accept gate. Coins that are rejected are routed to the reject exit.

SEPARATOR

The separator separates the coins into different routes, either to the coin storage tubes or the cashbox. It contains a solenoid bank and, at the bottom, a top level sensor assembly which is used to avoid tube overflow.

CONTROL BOARD

This is the main PCB which controls the way in which the change giver operates. There are several different control boards, but basically these are the 4 price for electromechanical machines, and the Executive, MDB and BDV for electronic machines.

SPINE

The spine provides the housing for all of the other modules. On the rear of the spine are the three standard keyhole fixing points for fitting the change giver into a machine.

TRANSFORMER ASSEMBLY

The transformer assembly is housed behind the keypad cover. To gain access to the transformer there is a screw located under the top flap of the keypad cover. Once this screw has been removed the keypad cover will lift off and the transformer is accessible. The transformer connects to the control board via two looms and is available in 24V, 100V, 120V, 220V, and 240V options.

Note: On CashFlow[®] 560 BDV and MDB change givers the transformer is replaced by a reservoir capacitor.

KEYPAD

The keypad is used to float or dispense coins and to re-configure some aspects of the way in which the change giver works.

DISPENSER

The dispenser is held in the spine by two clips, one on each side. It connects to the control board via a loom. It contains four dispense arms which, when operational, dispense coins from each of the four storage tubes. The dispenser also contains low level sensors which detect when the coin tubes are low on coins. It is possible to dispense coins from more than one tube at the same time.

COIN STORAGE CASSETTE

The coin storage cassette clips to the front of the change giver and contains four independent coin storage tubes. There are thirteen different sizes of tube, each numbered from 0 - 7. These cover most sizes of coins that you should want to route to coin tubes.

N.B. Some have a suffix of ".5" (i.e. 2.5), and dimensions range from 0 which has the largest bore and 7 with the smallest bore. Each tube has a designator fitted at the bottom. The size of the designator fitted is dependant upon the thickness of the coin. There are eight different sizes of designator each lettered from A - H.

The front cover is marked A,B,C,D to indicate the position of the fitted tube, as shown below. Coins of the following sizes can fit into each of the positions:

- Coin diameters from 15.0 to 26.0 mm in position A
- Coin diameters from 18.6 to 32.5 mm in position B
- Coin diameters from 15.0 to 29.2 mm in position C
- Coin diameters from 18.6 to 29.2 mm in position D

Tube Combinations

Tube	Position A	Position B	Position C	Position D
0	x	✓	x	x
1	x	✓	x	x
2	x	✓	✓	✓
2.5	x	✓	✓	✓
3	x	✓	✓	✓
3.5	✓	✓	✓	✓
4	✓	✓	✓	✓
4.5	✓	✓	✓	✓
5	✓	✓	✓	x
5.5	✓	✓	✓	x
6	✓	x	✓	x
6.5	✓	x	✓	x
7	✓	x	✓	x

COIN SIZES FOR EACH TUBE

Tube No	Part No	Min Coin Diameter	Max Coin Diameter
0	101812001	31.01	32.50
1	140164001	29.21	31.00
2	101825001	26.91	29.20
2.5	169494001	26.01	26.90
3	101838001	24.51	26.00
3.5	169509001	23.21	24.50
4	101841001	21.61	23.20
4.5	169512001	20.76	21.60
5	101854001	19.51	20.75
5.5	169525001	18.61	19.50

Tube No	Part No	Min Coin Diameter	Max Coin Diameter
6	101867001	18.11	18.60
6.5	169538001	16.70	18.10
7	101870001	15.00	16.69

Although there are different sizes of tubes and designators available, not every tube can be fitted into every position in the cassette.

There are prisms located at the top of each tube which, when combined with the optos on the separator form the top level sensor. The top level sensors are used to indicate when a tube is full. When a tube is full any further coins are routed to the cashbox.

The cassette can be automatically filled by feeding coins through the product, or manually filled by removing the cassette from the change giver.

On the front of the cassette are float indicators which you can position manually by sliding up and down.

Exact Change Equation

When the change giver, other than MDB product, detects that the quantity of coins in a coin tube is below the low-level sensor, a signal is sent to the vending machine to switch on the exact change light (ECL) so as not to risk short-changing a customer.

Setting the exact change equation ensures that the optimum combinations of change coins are always dispensed, by using coins from alternative tubes to make up the change required, and that the ECL is on for the minimum time possible.

An explanation of the process used to determine the optimum coins for change can be found later under the heading of Best Change Calculation.

Two exact change equations can be set using Route Alpha 250 terminal, addresses 236 and 237. The tubes A, B, C and D are coded 1, 2, 4 and 8

Address 236 = exact change equation, part 1 - offers the first option to use change coins from nominated tubes .

CashFlow[®] 560 changegiver Applications Design Guide

Address 237 = exact change equation, part 2 - sets a second selection of change tubes.

Address 383 can also be used, with BDV product only, to give an additional early warning setting, (in conjunction with addresses 271-274), and trigger the ECL to come on at an earlier point when the coin count in a selected tube becomes low coded 1, 2, 4, and 8.

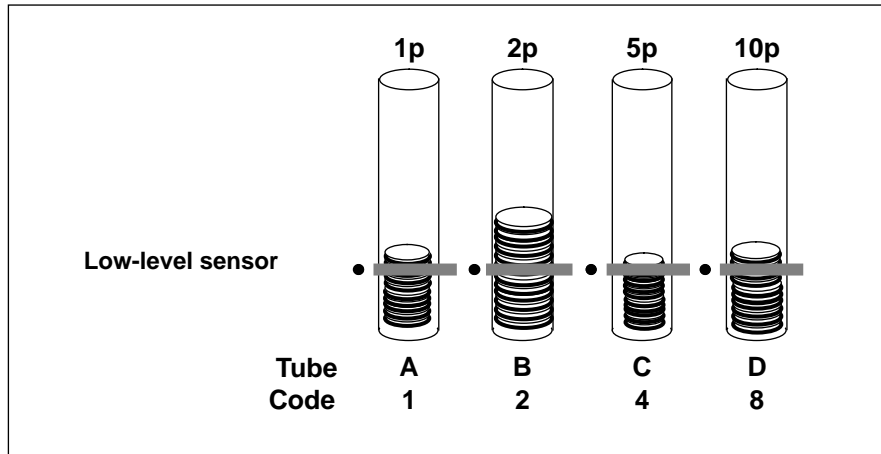

EXAMPLE: A four-tube changegiver contains 1p, 2p, 5p and 10p coins, and the vend price is 16p.

If 20p is inserted, the optimum change payout will be from tubes A and B. Therefore address 236 - exact change equation, part 1- must be set to 3 (using code 1 + code 2 to equal 3). This setting will ensure that the ECL comes on when tubes A and B become low.

If 50p is inserted, the optimum change payout will be from tubes A, B AND D. Thus address 237 - exact change, equation part 2- must be set to 11(using codes 1 + 2 + 8 to equal 11. This setting will ensure that the ECL comes on when tubes A, B and C become low. Setting both addresses 236 and 237 will cause the ECL to come on when tubes A and B, or tubes A, B and C become low.

If the vending machine becomes inhibited (blocked) this is signalled to the changegiver by the blocker signal. During the inhibited state, coin acceptance is disabled. This condition may occur because there are no products left in the machine, or the machine has developed a fault.

Using Exact Change Inhibit

When the machine is in exact change mode, selected coins can be inhibited, other than with MDB product.

Setting the exact change inhibit option will stop a specified coin or coins being accepted when the exact change light is on. It is usual to inhibit the highest value coin(s) to minimise the risk of the customer being short-changed.

When the coin level rises again above the low count, the ECL is turned off, and the inhibit option switched off so that the previously inhibited coins are accepted.

The coin set for the unit is divided into three exact change groups, in which each coin has a code. The groups are associated with addresses 232, 233 or 234. Set the range value of the addresses to the code of the coin you want to inhibit. Add the codes together to inhibit more than one coin at a time in each group.

Addresses 232 - coins 1 - 4 using codes 1, 2, 4 and 8

Addresses 233 - coins 5 - 8 using codes 1, 2, 4 and 8

Addresses 234 - coins 9 - 12 using codes 1, 2, 4 and 8

COIN ACCEPTANCE, ROUTING & RETURN

The change giver has a standard coin entry and exit chuting. Coin return via a reject lever is also standard. The coin acceptance, and the routing used on coin acceptance, are dependant on:

- The set up of various configuration items in the change giver EEPROM
- Other change giver conditions which will alter while the change giver is in operation

As a result of this, both coin acceptance and coin routing are dynamic, i.e. changing in time as the state of the change giver alters. The dependencies are detailed in the following sections.

COIN ACCEPTANCE

The acceptance of each coin is determined primarily by the set up of default inhibits in the EEPROM. This specifies which coins should always be inhibited (i.e. rejected). In addition to these defaults, extra inhibits will be imposed depending on the following conditions:

In normal mode with the overpay inhibit flag set:

- Coins which are not dynamically routed to the tubes will be inhibited and rejected if their value, plus the existing coin credit, cannot be returned due to lack of correct change coins
- Coins which would take the total system credit over the maximum allowed credit are inhibited
- Vend tokens are inhibited if the total system credit is not zero

In normal mode with the overpay inhibit flag clear:

The Vending Machine Contoller (VMC) overrules this in the MDB product

- If use exact change has been signalled, the exact change inhibits are imposed
- Coins which would take the total system credit over the maximum allowed credit are inhibited
- Vend tokens are inhibited if the total system credit is not zero

In float mode:

- All coins which are not dynamically routed to the tubes will be inhibited

In price teach mode:

- Coins which would take the total system credit over the maximum allowed credit are inhibited
- Vend tokens are inhibited

Global Coin Inhibit

In addition to the individual coin inhibits described above, a global coin inhibit can be imposed. This will inhibit all coin acceptance regardless of any other conditions. A global inhibit is imposed when:

- Manually dispensing coins either from the key pad or the terminal
- Returning credit
- A vend is in progress (VMC function on MDB)
- A price is on the display due to a product selection being made with insufficient credit. (When in price display mode). (Not on MDB)
- Value of tube contents is on the display. (Not MDB)
- Any bits in the EEPROM error register are set, apart from code 5
- A free vend token has been accepted
- An executive type vending machine has indicated that it requires a free vend
- The host machine has indicated it is inhibited
- The cashbox error code or if the protocol A error code is set
- The blocker signal is not present

COIN ROUTING

The coin routing used is determined in the EEPROM. If a tube is not fitted this is indicated as 00 on the MEI[®] Route Alpha 250 terminal display. In addition, there are conditions which prevent coin routing to a tube even when it does store the coin. These are any of the following:

- The tube full sensor reads covered (or has failed its self-test, if test enabled on acceptor)
- There was a fatal dispenser error on that tube
- The tube counts held in change giver RAM are equal to, or greater than, the maximum level for that tube.

The routes, determined by all the above criteria, are the dynamic routes. Before a coin can be routed it must first be accepted. If a coin is rejected none of the above applies.

CHANGE PAYBACK

In general the change giver will attempt to return any coin credit to the consumer, in the best possible coin mix. However, this simple statement requires clarification.

Use of Tubes

- The change giver will only attempt to use tubes which are shown as fitted, and have not been disabled by the occurrence of sensor or dispenser faults
- If a tube is fitted and is not disabled, it will be allowed to be used for change payback only if its tube counts are above the safe count value at the start of the change payback sequence
- The change giver will not function if the coin storage cassette is not fitted

Best Change Calculation

Once the tubes that can be used have been determined the best coin mix to pay back the change is calculated. Best coin mix is defined as the first of the following found to be possible:

- Correct change paid with minimum number of coins
- Correct change paid with non-optimal coin mix
- Closest change paid with minimum number of coins
- Closest change paid with non-optimal coin mix
- No change paid

Once the best coin mix has been determined the dispensers will start to pay the change out. The software will drive as many motors as possible at once to expedite the change payback. (Not MDB)

Should either of the following occur the dispense sequence will be suspended once each motor has got to its home position:

- The tube has run out of coins while coins are still required. This could occur if the low level sensor/s go from covered to uncovered, causing a tube count recalibration, which reduced the number of coins held in the tube. (Not MDB)
- A dispenser error is detected (stall, etc.)

The software will then re-compute the best coin mix to pay back the credit still remaining and re-start the dispensers with this new coin mix. The above will be repeated until all the change which can be dispensed has been paid.

TUBE SENSOR USAGE

This section describes the operation of the tube sensors in more detail. The sensor operation significantly affects the users perception of how the changegiver appears to operate.

Each tube has associated with it three sensors:

- The full level sensor (opto sensor)
- The low level sensor (opto sensor)
- The tube dispenser home position sensor (reed switch)

Full sensors

Effect on coin routing

The changegiver cannot read the tube full sensors directly, but must request their status from the acceptor module. The acceptor module then performs a self-test of the full sensors. The acceptor module reports both the reading of the sensor, covered or uncovered, and the outcome of the self-test, OK or failed.

The changegiver will perform the following actions, on a tube-by-tube basis, based on the self-test results and the sensor reading:

Self-Test Result	Sensor Reading	Changegiver Action
OK	Un-covered	This is the normally expected result. The changegiver will clear a full sensor error, if flagged. It does not take any further direct action. However the routes may be updated if the tube counts have got to their maximum level
OK	Covered	This is a fault condition, as the maximum level a tube should reach is 3 coins from full. The changegiver will signal a full level sensor error. If the low level sensor is reading covered then there is a good chance that the tube is really full, so the changegiver will recalibrate the tube counts to the pre-programmed Full Number.

Self-Test Result	Sensor Reading	Changegiver Action
Failed	Un-covered	This condition cannot occur, as the acceptor will always assume any failed sensors are covered, and will act as if this is so.
Failed	Covered	<p>This is a fault condition, due to the failure of the acceptor module's sensor self-test (opto was seen on with the LED being off). The changegiver will signal a full level sensor error. It will ignore the reported reading, and continue to use the last (good) reading before the failure. The routing will be updated. The tube is still used for dispense. If all 4 main tube sensors are reported as failed, then the cassette is assume to be removed, and a cassette out error will be flagged.</p> <p>Note that sunlight, or other intense light source can affect the sensor self-test, causing it to fail. Thus the changegiver will inhibit the self-test feature when float or price teach mode is entered. When this mode of operation is selected, the self-test result will always be OK.</p>

Coin cassette removal detection

If the coin storage cassette is removed, all the tube full sensors on the tubes will read covered. Should the changegiver detect this all tubes full condition, it will flag a cassette removed error and will indicate a changegiver error on the error LED. No change payback will be attempted from the tubes. Manual dispensing from the tubes will still be allowed, but the tube counts will not be decremented. Coins will still be accepted but routed to the cashbox.

The error will be cleared as soon as a coin is accepted or a dispense

attempted with the coin cassette back in place. Note that if all tubes really have overfilled to cover the sensors then a cassette removed error will be indicated, but will clear once the tube level drops.

Full sensor error detection

The changegiver will detect full sensor errors on dispensing from a tube if coin storage cassette removal has not been detected. The appropriate full sensor error register will be set and a changegiver error will be indicated on the error LED. Since the sensor reads full the tube will no longer be routed to, but no other action will be taken, i.e. the tube will still be dispensed from.

The full sensors are read on initialisation, acceptance and dispensing coins. Full sensor errors relating to a tube are cleared whenever a full sensor reads uncovered. Note that this means that if more than 1 coin covers the full sensor, the full error for that tube will initially be set on dispensing from that tube, but it will be cleared again as soon as the sensor becomes uncovered.

Coin count re-calibration

When accepting coins, the full sensors will be used for re-calibrating the number of coins in the tubes. For any given coin type the number of coins that it takes to cover the full sensor can vary due to variations in coin thickness. For this reason the tube counts for a tube will be set to be their full re-calibration number only if:

- The sensor status has changed
- The result of the sensor self test was good
- A coin cassette error has not been detected
- The recorded tube counts are more than 9 from their expected level:

Low sensor error detection

The low sensor is checked at the following times:

- On power-up
- Before beginning any dispensing, either manual dispensing or credit return
- Immediately after every coin is paid out
- One second after a coin is accepted

The status of the low level sensors will be held in non-volatile memory, thus preserving this information for the next power-up.

Coin count re-calibration

Low level recalibration is intelligent in its handling of tube storage cassette removal and replacement. The main assumption made is that the tube storage cassette is not removed during a change return operation. The following table gives the details of the low sensor operation.

A tolerance of +/-one coin is applied to the tube counts before recalibration on low level sensors is done. This reflects the fact that due to the variables, both electrical and mechanical, it is unlikely that the number of coins in a tube will always be the same.

Thus, if the tube counts are within one of their expected level , no recalibration will occur when the low sensor goes from covered to uncovered.

CashFlow[®] 560 change giver Applications Design Guide

The following table gives a brief summary of the low sensor operation.

Read at	Status	Action
Power-up	UNCOVERED	If required reset of tube counts to 0
	COVERED	If required reset of tube counts to tube float level
Coin acceptance	UNCOVERED	If required reset of tube counts to tube low count
	COVERED	If required reset of tube counts to tube float level
Prior to dispense	UNCOVERED	If required reset of tube counts to tube low count
	COVERED	If required reset of tube counts to tube float level
During dispense	UNCOVERED	If required reset of tube counts to tube low count 1
	COVERED	None
Reset tube counts	UNCOVERED	If required reset of tube counts to tube safe count
	COVERED	If required reset of tube counts to tube float level
Exit Float Mode	UNCOVERED	If required reset of tube counts to tube low count
	COVERED	If required reset of tube counts to tube float level

Home sensors

The function of the home sensors is to signal that the dispenser arms are in the correct parked position before an attempt to dispense coins from the coin storage cassette is made. Should this fault have occurred then an error signal will appear on the (red) error LED on the keypad, which will flash on and off.

To remedy this the coin storage cassette should be removed and then pressing the (yellow) mode key twice. This will drive the dispense arm solenoids and all 4 of the dispense arms will be parked in the correct position in sequence.

PRODUCT INTERFACES

The external interfaces to the change giver product can be divided into two groups and are explained in the following pages.

- Electrical interfaces: includes looms to interface host machine with 4-price, Executive, BDV and MDB versions, connectors and power supplies.
- Man machine interfaces: includes keypad, terminal and credit display.

These are described in the following sections.

Mechanical Interface Drawings showing the space envelope, mounting detail, reject mechanism clearance detail and coin routing are at the end of the book in the Appendix.

The current product types available are;

- CashFlow[®] 560 - 4 price - A four price electromechanical change giver

A credit display can be provided, if required, for use with the above variant.

- CashFlow[®] 560 - Executive - change giver with an electronic Protocol A serial interface
- CashFlow[®] 560 - BDV - change giver with an electronic BDV serial interface
- CashFlow[®] 560 - MDB - change giver with an electronic MDB serial interface

ELECTRICAL INTERFACES

The diagram below illustrates the external electrical interfaces and options for the CashFlow[®] 560.

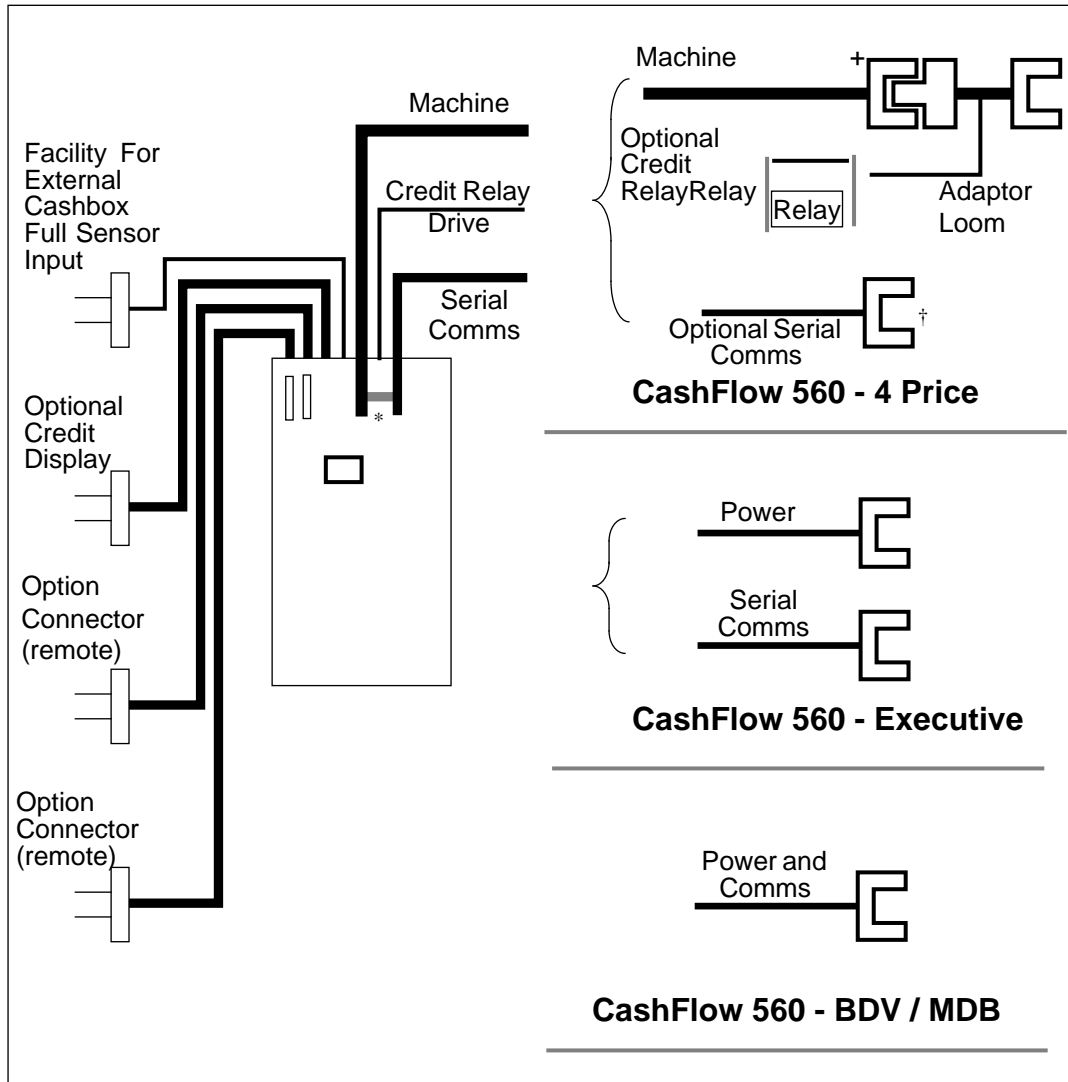

NOTE: The machine and serial communications loom are connected together within the change giver for the CashFlow[®] 560-BDV and MDB products.

CashFlow[®] 560 changeover Applications Design Guide

The mains electro-mechanical interface circuit diagram for CashFlow[®] 560 4 Price is shown below.

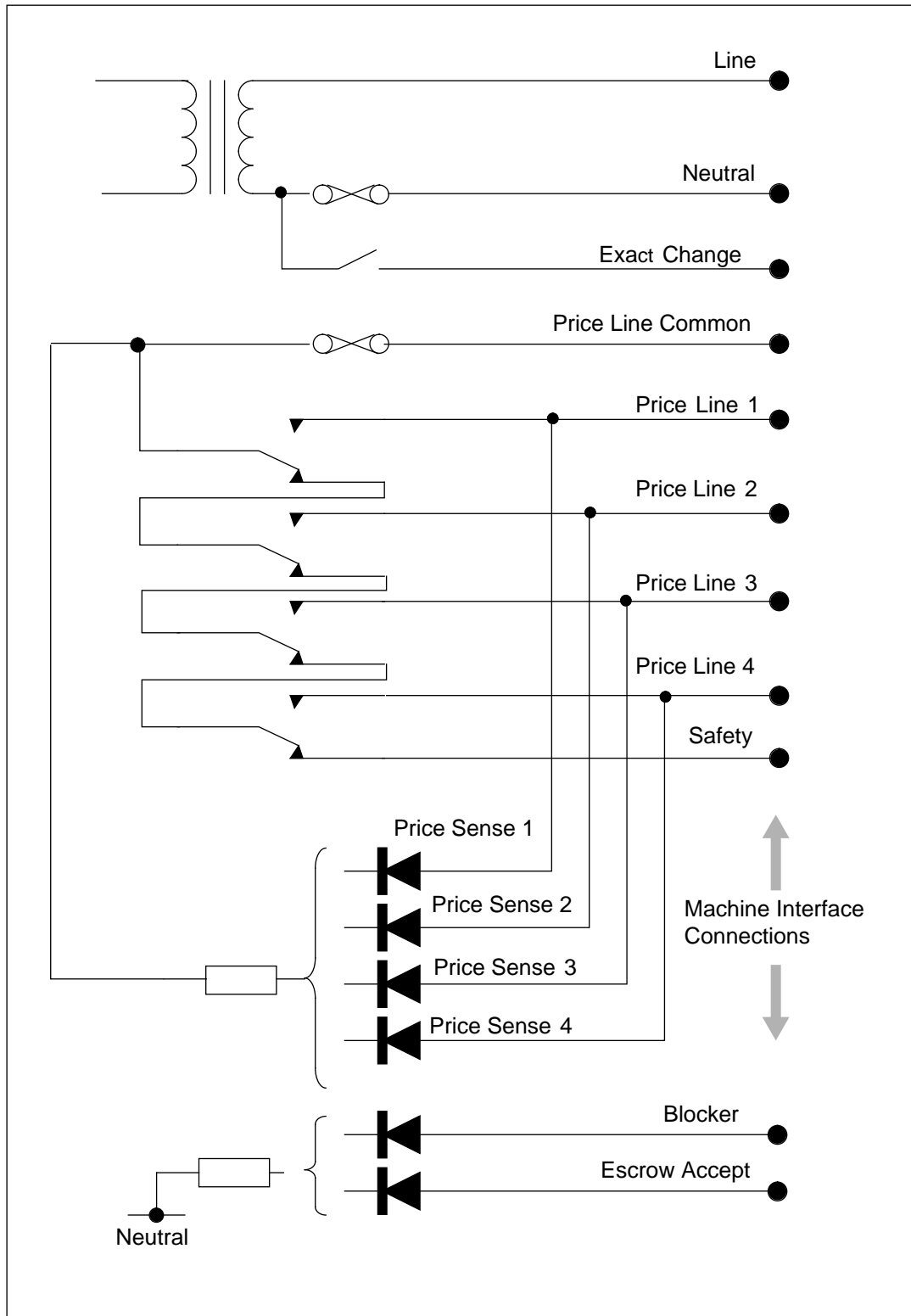

Host Interface for CashFlow 560 4 Price

Protocol A Equivalent Circuit

As applicable to Executive, BDV and MDB versions.

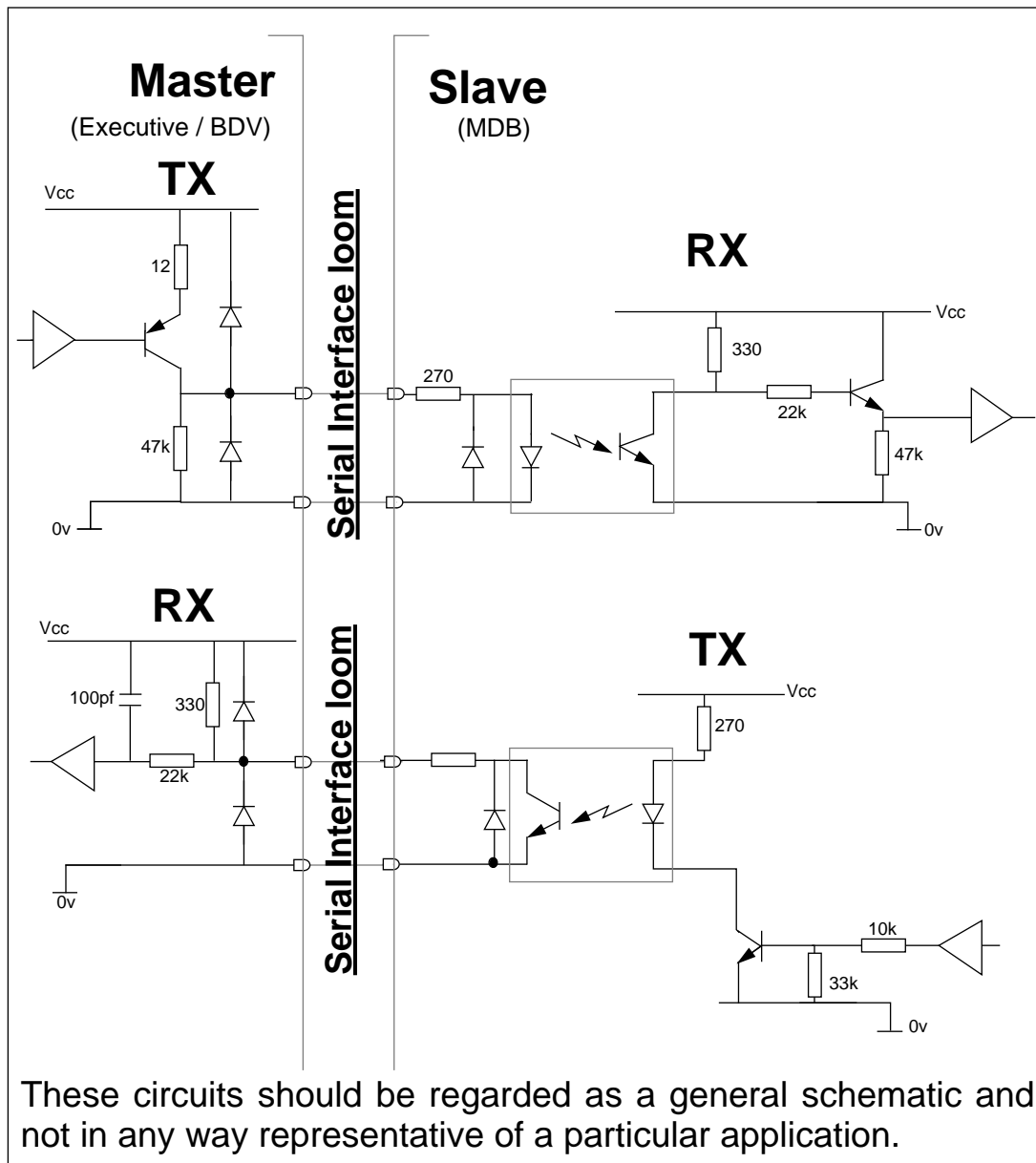

The CashFlow[®] 560 Executive, BDV and MDB products do not require any related electro-mechanical interfaces. However, the Executive does require a 24V A.C. power supply as illustrated below.

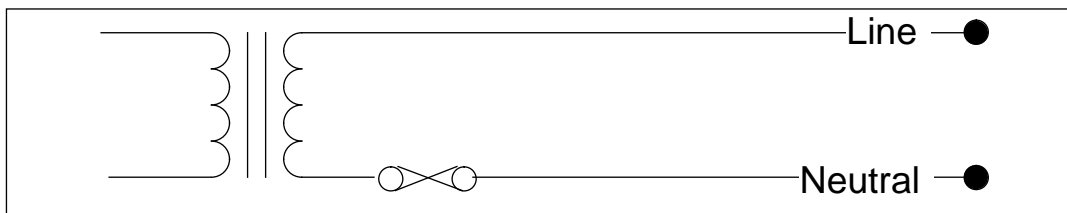

Interface for CashFlow[®] 560 Executive

ELECTRO MECHANICAL INTERFACE

All electro-mechanical interface connections between the changegiver and the host vending machine are electrically isolated. Outputs are isolated via the relays (i.e. price line outputs) and the inputs from the machine are current limited and optically isolated. The standard electro-mechanical interface parameters for all changegivers defined in this specification are as follows:

EXACT CHANGE OUTPUT

(Switched neutral). Rated 0.5 Amps AC resistive load. Fused 1.6 Amps thermal. Fault rating 3.5 Amps.

When the changegiver detects the change available in the tubes is low it indicates exact change to the vending machine. The machine normally uses this signal to illuminate a lamp informing the customer to use the correct money.

CREDIT RELAY DRIVE

(Switched Ground). Open collector drive provided (includes flyback diode) - 20mA @12V.

The credit relay is only available on the 4 price changegiver as an option located outside the unit.

SAFETY LINE

(Switched Price Line Common). Rated 2.6 Amps. Fused (via price line common) 3.15 Amps fast. Fault rating 7.0 Amps.

This output is normally connected to price line common via all the price line relays (in their off state). When any price line becomes active the safety line becomes open circuit within the changegiver.

PRICE LINE COMMON

(Normally connected to Line). Rated 2.6 Amps AC inductive load. Fused 3.15 Amps fast. Fault rating 7.0 Amps.

PRICE LINE OUTPUTS

Rated 2.6 Amps AC inductive load (worst case power factor of 0.5). Fused (via Price Line Common) 3.15 Amps fast. Fault rating 7.0 Amps.

A sense input will be seen when >1.5mA is flowing through the sense input. When a sense input becomes active the changegiver determines the price to be charged for the selection requested. If sufficient credit exists it will energise the appropriate price line relay. This relay will disconnect Safety from price line common and connect price line common to the selected price line output enabling the vending machine to proceed with the vend cycle.

MACHINE INTERFACE

The normal idle state of the Electro-mechanical / 4 Price machine interface with no credit is as follows:

- Blocker input active (connected to LINE)
- EA input (if present) - inactive
- Sense input lines inactive (open circuit)
- Safety Line output connected to price line common (via ALL price line relays)
- Price line outputs inactive (open circuit)
- Credit relay off (contacts open) - when optional box fitted
- Exact change output inactive (contacts open)

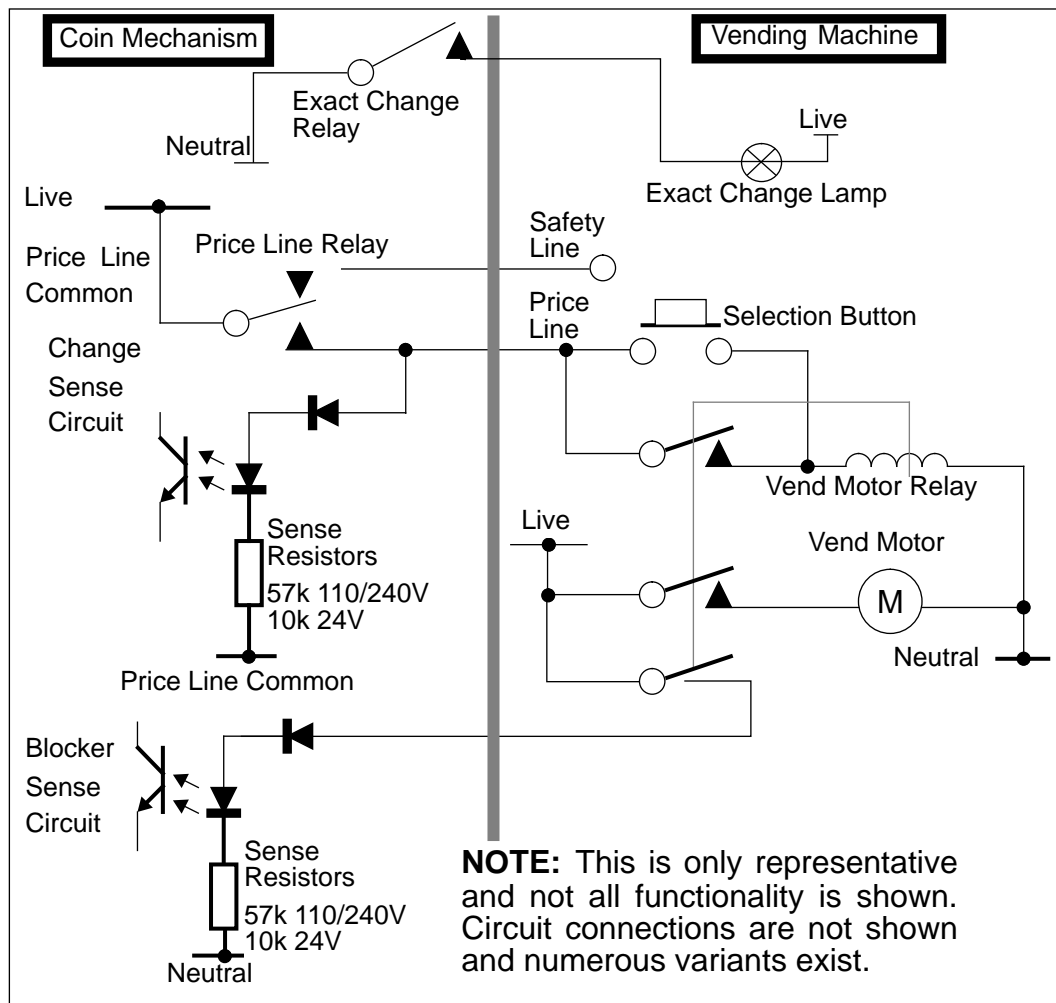

The 4 price changegiver has 4 input/output lines, providing for 4 sense inputs, and 4 price line outputs. When a product selection is detected the appropriate price line output is enabled (if sufficient credit exists). As the price line relay outputs are interlocked, enabling one price line output ensures that the other price line outputs are disabled. When the reset condition is detected the price relay is turned off.

SINGLE / MULTI VEND

Unused credit (change) is returned to the customer either automatically or on demand by pressing the reject lever. If the change giver is set to single vend mode any unused credit is returned automatically immediately after the vend finished condition is met. In multi vend mode the credit balance is not returned until requested by the customer (or automatically after a selectable timeout period has elapsed).

SENSE INPUT TIMING

During the period between pressing the product selection button and the price line output becoming active the change giver must determine the price line of the selection, look-up the vend price and decide whether to allow the vend, and if so energise the price line relay. If the sense input from the vending machine is A.C. the sense current is only detected during the positive half cycle, therefore it may be $\frac{1}{2}$ cycle (i.e. 10mS) before the sense input is detected, leaving 25mS for everything else.

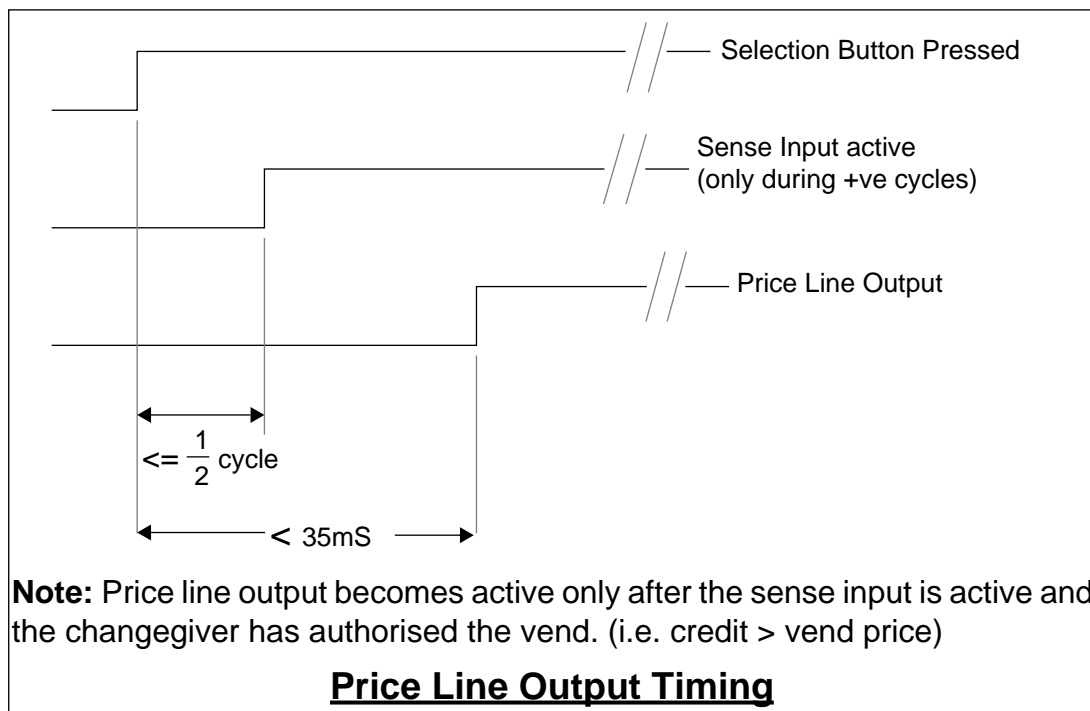

VEND START

When a price line output has been energised the change giver will wait for the vend start signal. This is indicated by the blocker input becoming inactive. If the vend start signal is not seen within 2.5 ± 0.5 seconds of the price line output being energised the price line

output is removed (excluding blocker hold reset mode). The price line output will be energised again if the sense input is still active and sufficient funds exist to pay for the product requested.

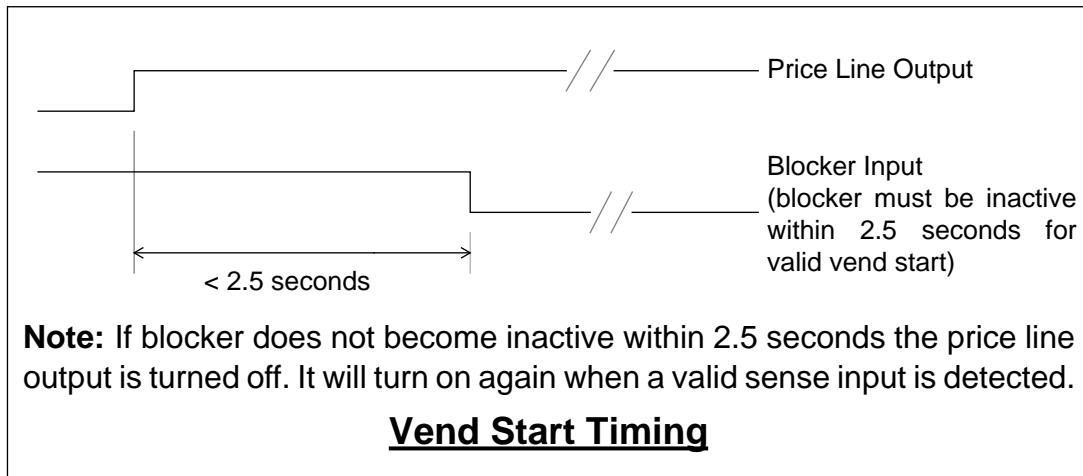

VEND FINISHED

While the vend is in progress the vending machine holds the blocker signal inactive. When the vend is finished the blocker signal returns to its normal active state. As far as the changegiver is concerned the vend is considered to have finished when the reset conditions are met, and the price line output is disabled. The changegiver can be programmed to several different reset conditions to suit different vending machine interfaces:

- Blocker reset
- Delayed blocker reset
- Blocker hold reset
- Escrow accept reset

If the reset conditions are not met (i.e. the vend failed), the vend price will be paid back to the customers credit balance.

BLOCKER RESET

The changegiver assumes the vend has finished successfully as soon as the vend start signal is received (blocker signal is seen to be inactive). The price line output is turned off at this point, with no added delay. This is typically <30 mS.

DELAYED BLOCKER RESET

Blocker reset is the most commonly used reset condition

In this reset mode the price line output remains active for either 30 mS (most commonly used) or 200 +/- 10 mS after the vend start signal is detected (blocker signal removed). The vend is assumed to have finished successfully after this delay and the price line output is turned off. The product may be in either 30mS or 200mS mode.

The delay is required to ensure the price line output is active for sufficient time for some machines to latch the signal.

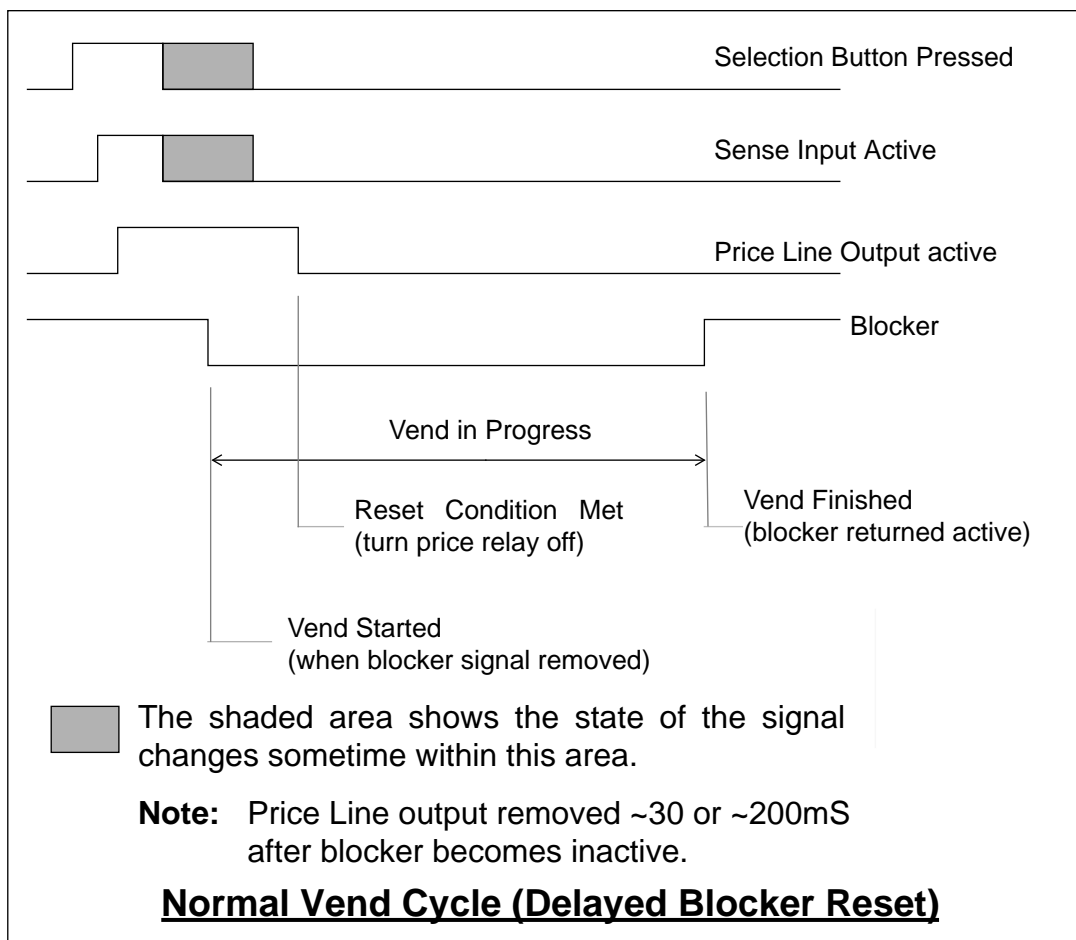

BLOCKER HOLD RESET

The changeover waits for the vend start signal (blocker) to return to its normal active state to indicate the vend cycle was successful. When blocker returns the reset condition is met the price line output is disabled.

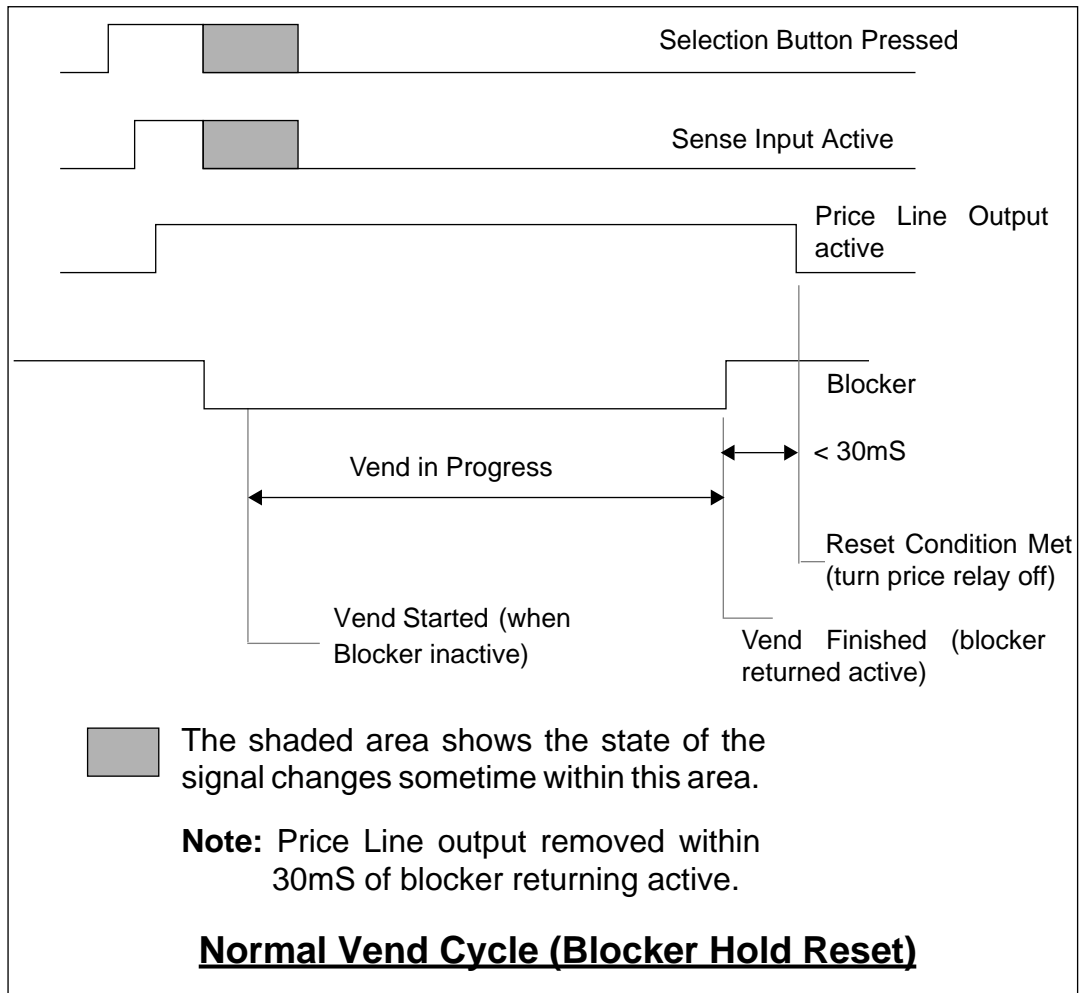

ESCROW ACCEPT

In this mode the escrow accept (EA) input is used in conjunction with the blocker input to indicate a successful completion of a vend cycle. Normally, blocker removal signals the vend has started. The end of the vend is indicated when EA becomes active while blocker is still inactive. If the blocker signal returns to its active state before EA is active the vend is deemed to have failed, the price output is deactivated and price of the vend is added back to the credit so that the customer can try again or have his money back.

To allow for any fault condition the change giver will only wait 1 minute (+/- 2 seconds) for the EA reset condition to be met. If this does not occur the vend is assumed to have failed and is dealt with in the same way as for blocker hold reset.

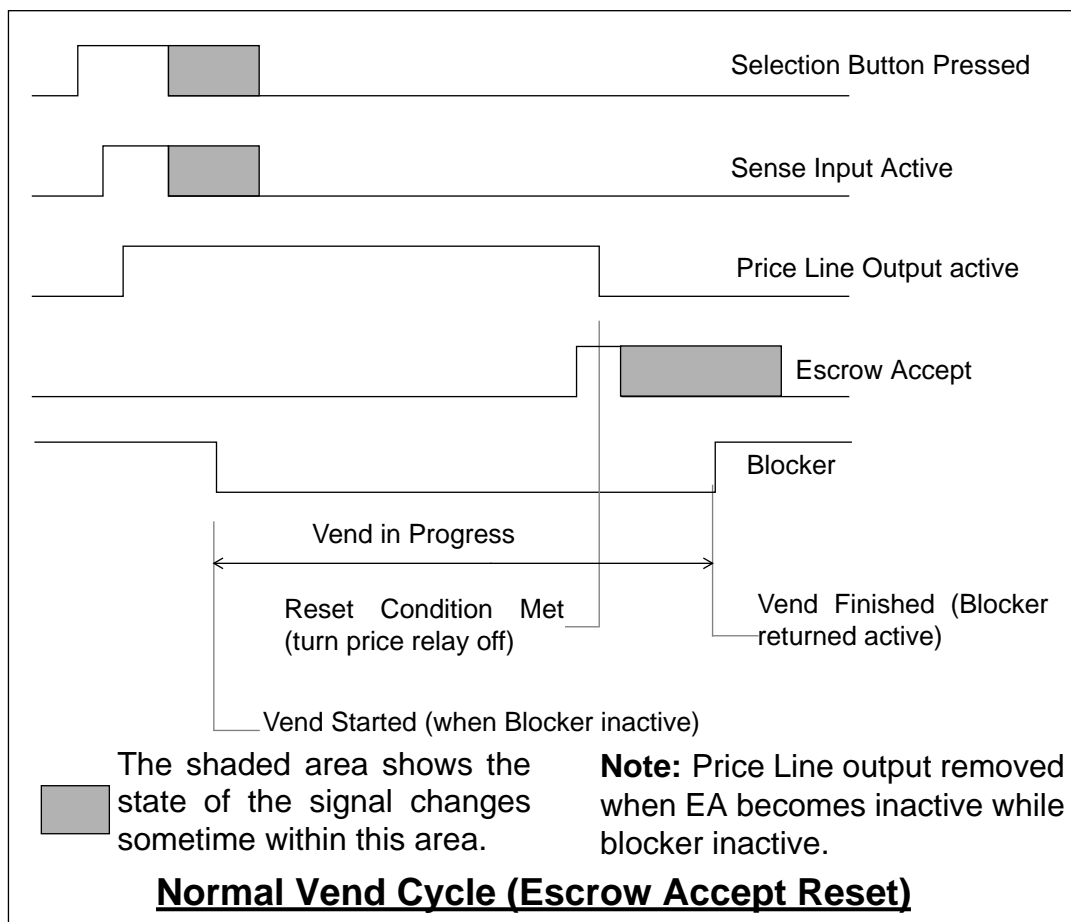

**PRICE SENSE / BLOCKER / ESCROW ACCEPT / VEND START/
INHIBIT INPUTS**

Rated < 100 mA. Fault protection by circuit impedance.

The maximum source impedance (from vending machine) to allow the change giver to correctly sense an input is dependant on the voltage profile of the unit as follows.

Mains Voltage Profile Range	Mains Activated Minimum Source Impedance for OFF Condition	Mains Activated Max Load Impedance
20.4 - 26.4 VAC	118K ohms	10 k ohms
87 - 121 VAC	475K ohms	10 k + 47 k ohms
95 - 132 VAC	525K ohms	10 k + 47 k ohms
187 - 242 VAC	1 M ohms	10 k + 47 k ohms
212 - 264 VAC	1M1 ohms	10 k + 47 k ohms

EXTERNAL CREDIT DISPLAY

For electro-mechanical interface applications the external display, if fitted, can provide the following information:

- Current credit in real money (Consumer)
- Vend price in real money, used in price display mode(Consumer)
- Accumulated credit in price teach & float modes (Operator / Route person)
- Power-on indicator (Service engineer)
- Value of cash in tubes (Operator / Route Person)

DISPLAYING CREDIT

If there is credit in the system, either coin or value token, then the total value of this credit will be displayed. The display will be in real money units. Any leading zeros will be blanked. The decimal point will be lit according to the decimal point setting in the EEPROM. A decimal point setting of 0 indicates zero places of decimal, i.e. the decimal point is lit on the right hand digit. A decimal point setting of 1 indicates one place of decimal, and so on. Any value of decimal point over 4 will be ignored and no decimal point will be lit.

If there is free vend credit available, either by free vend token or host machine free vend, the credit display will indicate this by a display of 5 dashes on the middle segments.

If there is no credit in the system, the display will show a single 0 in the right hand digit. No decimal point will be lit.

CANCELLING CREDIT

If you have been testing or resetting the change giver outside of a shifted mode you may accumulate credit in real money terms. To cancel any credit, press the mode key once followed by the A key twice.

DISPLAYING VEND PRICE

If price display is enabled, and you make a selection whose value is less than the current system credit, then the display will show the price of the vend, in real money, while the selection is active. Leading zero blanking and decimal point will be handled as the display of credit.

DISPLAYING PRICE TEACH CREDIT

If the change giver is in price teach mode, the current value of credit will be displayed in real money values. Leading zero blanking and the flashing decimal point will be handled as the display of credit.

DISPLAYING FLOAT VALUE

If the change giver is in automatic float mode, the total value of any coins accepted as float will be displayed in real money values. Leading zero blanking and the flashing decimal point will be handled as the display of credit. This value is removed when the change giver returns to normal operation.

POWER ON INDICATOR

On system power-up or reset, the change giver will light all segments of the display for 0.5 seconds. If there is no host or change giver fault present, the red LED will light. This will provide you with a basic check of the display and associated H/W.

DISPLAYING TUBE VALUE

A display of the value of coins the change giver thinks are contained in the tubes can be obtained by pressing the mode key twice with the tube cassette fitted. The tube contents value will be displayed for 2 seconds on the display.

Note that the calculation is based on tube counts, and on the value of the first coin type in the tube.

VOLTAGE RANGES

The following profiled mains voltage ranges are supported across the defined 4 price and Executive product range:

- 20.4 - 26.4VAC covering voltages 24v +10%, -15%)
- 87 - 121VAC (covering voltages 100v -13%, +21%)
- 95 - 132VAC covering voltages 120v +10%, -20.8%)
- 187 - 242 VAC covering voltages 220v +10%, -15%)
- 212 - 264 VAC covering voltages 240v +10%, -11.7%)

For details of BDV and MDB product please contact your nearest regional MEI office.

POWER CONSUMPTION / RATING

	AC Profiles	BDV/MDB
Quiescent power	15VA @ 50Hz	4.5W
Maximum power	20VA @ 50Hz	8 W
Input current rating	3.52A (min)	2.2A (min)
Internal fuse rating	1.6A (Thermal Delay)	1.0A

TERMINAL CONNECTOR

This connector is on the front of the acceptor module. It is used with the MEI[®] Route Alpha 250 terminal to access and reconfigure certain aspects of the way in which the change giver operates. A list of the items and relevant addresses can be found in a later section.

The connector type is: Staked pins 0.1" DIL

Pin No	Function
1	Vneg (0V)
2	Data (Tx / Rx)
3	GND (0V Screen)
4	Busy
5	GND (0V Screen)
6	Vin (12V)

MAN MACHINE INTERFACES

KEYPAD

All changegivers have a keypad mounted on the front face. Two LEDs are also mounted in this area to indicate the operational state of the changegiver. The keypad will enable the following functions to be performed:

- Dispense coins
- Set price(s). See Note below.
- Float the changegiver
- Reset tube counts
- Home the dispensers
- Display the value of coins in the tubes

NOTE: Setting Prices is available at all times with electro-mechanical product, unless Route Alpha terminal address 245 has been set to inhibit.

With BDV and Executive product it will apply only when Route Alpha 250 terminal address 238 has been activated.

Setting Prices function is not available for MDB product.

The keypad has four letter keys and a mode key. The mode key allows shifted functions to be associated with each of the letter keys. Two LEDs provide simple diagnostic information and will assist the use of the keypad. The diagram below shows the layout of the keypad and its associated labeling. The following sections describe its operation.

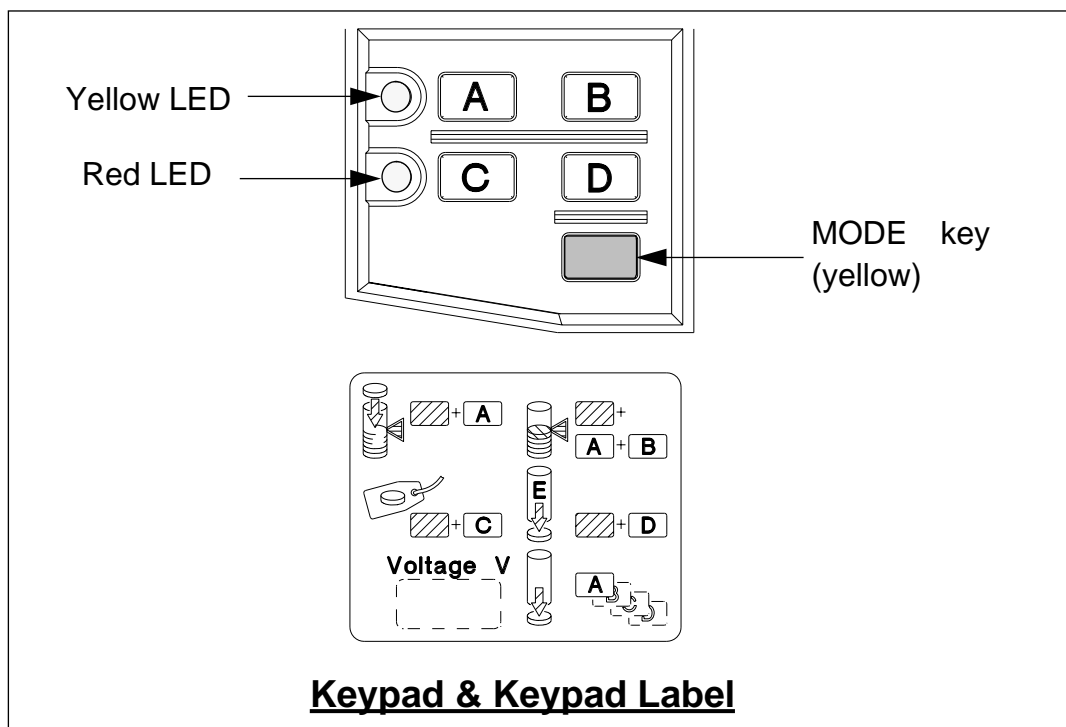

LED Usage

The top (yellow) LED is used to indicate whether the keypad is in normal or shifted mode. If the LED is off, the keypad mode is in normal mode. When the mode key is pressed, the yellow LED will start to flash at 2 Hz ($\pm 1\%$) to indicate that the shifted functions defined by the icons on the keys, are accessible. Note that the mode key does not need to be held down to access the shifted functions.

If no further key is pressed within 10 seconds, or the mode key is pressed a second time, the keypad will return to its normal mode. The yellow LED will go off, and the shifted functions will be disabled. If a letter key is pressed within 10 seconds, then the changegiver will turn the yellow LED on continually, and attempt to perform the required action. See the following sections for details of the shifted functions.

The bottom (red) LED is used to indicate the fault status of the system. If there are no errors, the LED will be illuminated continually. If a changegiver error is detected, then the red LED will flash at 2Hz ($\pm 1\%$). If a fault is detected on the host machine, then the red LED will be turned off. Machine faults will take precedence over changegiver faults.

If the state of the system requires that both LEDs flash, then they will be synchronized to each other in anti-phase (i.e. yellow on - red off, yellow off - red on).

Manual Coin Dispense

If the changegiver is idle (i.e. not vending or accepting coins), the user can manually dispense coins from the 4 tubes by simply pressing the relevant letter key. On a single press-and-release of a letter key, the changegiver will attempt to pay a single coin from the requested tube.

If you wish to get more than 1 coin from the tube, you can continue to hold the key down. This will cause the changegiver to start dispensing further coins at the rate of 1 coin every 0.5 seconds (subject to the dispenser cycle time being less than this).

If you release the key within 3 seconds of the initial press, then dispensing will stop after the current coin is dispensed. Multiple dispensing is not allowed on empty tubes (tube counts = 0).

If the key is held for more than 3 seconds, dispensing will latch, and release of the key will have no effect. The dispenser will continue to dispense a coin every 0.3 seconds (subject to the dispenser cycle

time being less than this) until the tube counts reach their programmed safe count, or any key is pressed.

If 2, or more, letter keys are pressed at the same time, then the changegiver will pay coins from the selected tubes in the same manner as described above. Note that the 3 second latch time is measured from the time the last key is pressed, and dispensing will not unlatch until all the selected tubes reach their programmed safe count.

Automatic Tube Float (Float Up)

You can refill the tubes to their pre-programmed float level by the use of the float function. Float is only available if the changegiver is idle. To access float, press the mode key to get the shifted functions, and then press the key with the float icon (key A). Entering float mode will clear any accumulated credit, and will be indicated on the changegiver's credit display by all decimal points being lit.

On entry to float, a longer time-out of 45 seconds will be started. You can then enter coins via the acceptor. The changegiver will automatically accept only the coins required to bring the tubes up to their programmed float level. On a tube reaching the required float level, any further coins of that type will be rejected. The value of any coins accepted as float will be accumulated, and displayed on the credit display (if fitted). This display value will be shown with the decimal point flashing.

During float the yellow LED will remain on, indicating that a shifted function is active. The changegiver will exit float mode, and turn off the yellow LED, if any of the following occur:

- No float coins accepted during a 45 second period
- The float key (A) is pressed
- The float down (C) key is pressed
- The reset tube counts key is pressed

Note that on exit of float, there is no need to press the mode key first, as the shifted functions are already active. When float mode is exited the changegiver will clear down the credit display, and resume normal coin acceptance.

If float mode is exited by either of the first two methods above, then the tube counts will not be modified further. If float mode is exit by pressing the reset tube counts key, then the tube counts will all be set to their pre-programmed float levels.

Float Down Mode

When you wish to float down the tubes, simply press the mode key to get to the shifted functions, then press the A key to enter float mode, followed by the C key. At this point the change giver will start to dispense coins until all tube counts reach the pre-programmed float levels. Note that if all counts were equal to or less than the float levels, then no dispense will occur.

Resetting Tube Counts

You can force the tube counts to be set to their pre-programmed values by use of the reset tube counts function. In order to avoid inadvertent resetting of tube counts, this function is only enabled if the change giver is in float mode, and an IDTS audit FEM is not present.

If key B is pressed while the change giver is in float mode, then all of the tube counts for the 4 main tubes will be set to their pre-programmed float levels. The change giver will then exit float mode. If the actual number of coins in the tubes do not match these float levels, then the coin counts will be incorrect until recalibration occurs. If access to this function is attempted when the change giver is not in float mode, i.e. pressing the mode key, then pressing the reset key, it will be ignored. The keypad will revert back to normal mode after 10 seconds and the yellow LED will then stop flashing.

Price Teach

Subject to the earlier note the prices held by the change giver can be set using the price teach function. Price teach is only available if the change giver is idle. To access price teach, press the mode key to get the shifted functions, then press the key with the price icon (key C). Entering price teach mode will clear any accumulated credit, and allow the user to clear credit, and will be indicated on the change giver's credit display by all decimal points being lit.

On entry to price teach, a longer time-out of 45 seconds will commence. You can then enter coins via the acceptor to the value required for the price to be set. Any coins entered will be accumulated as credit, and displayed on the credit display, if fitted. This display value will be shown with the decimal point flashing.

If there is accumulated credit, then any selection which becomes active will have its price set to the value of credit accumulated. If no credit was accumulated, then any selections made will not have their price modified. This is to prevent inadvertent zeroing of prices on permanent sense machines. Price teach only allows the setting of non-zero prices. Should you wish to clear a price to zero, then the Route Alpha 250 terminal must be used.

The sequence of inserting coins then making a selection can be repeated for all selections for which you wish to modify the price. Note that the main principle of price teach is that selections will have their price set to the current accumulated credit value, so that if a number of selections are required to be set to the same price, once the correct credit value is reached, all that needs to be done is to press the selection buttons.

During price teach the yellow LED will remain on, indicating that a shifted function is active. In addition, all keys except the price teach key will be ignored. The change giver will exit price teach mode, and turn off the LED, if any of the following occur:

- No activity relating to price teach made during a 45 second period.
- The price teach key is pressed.

Note that on exiting price teach, there is no need to press the mode key first, as the shifted functions are already active. When price teach mode is exited the change giver will attempt to return any accumulated credit to the user using the tube coins.

Note that on serial interface change givers, the prices are not normally held in the change giver and are thus inaccessible to this form of update, unless the price holding option is enabled via the support terminal.

Homing the Dispensers

You can home all the dispenser arms by first pressing the mode key to get the shifted functions, then pressing the mode key a second time. This will home each of the dispenser arms which are not seen to be at home, as read by the position sensors. This will only work if the tube cassette is removed.

Displaying Tube Value

You can easily get a display of the value of coins the change giver thinks are contained in the tubes by pressing the mode key twice with the tube cassette fitted. This will cause the tube contents value to be displayed for 2 seconds on the change giver's credit display.

Note that only tubes which are set up as fitted will be included in this calculation. Note also the calculation is based on tube counts and on the value of the first coin type in the tube.

INTERNAL DIAGNOSTICS & ERROR HANDLING

The indication of an error being present either in the host or in the change giver is given by the red LED. This section details various errors, and the action taken by the change giver.

- Host machine problems
- Coin handling problems
- On-board EEPROM problems
- Audit FEM problems
- FIB communication errors
- Miscellaneous errors

HOST MACHINE PROBLEMS

Host Inhibited

On both electro-mechanical and electronic hosts, an indication is provided to the change giver if the host is inhibited (e.g. blocker inactive on electro-mechanical machines, no polling on MDB). The error handling for this condition is:

- Indicate host error on LED
- Disable all coin acceptance in normal mode
- Disable all coin acceptance in float mode
- Disable all coin acceptance in price teach mode
- Manual dispense is still allowed
- Route Alpha 250 terminal comms still allowed
- Change giver will continually check if host is re-enabled

Removal of Blocker

The start of vend condition on electro-mechanical hosts is signalled by blocker becoming inactive after the price relay has been turned on. Normally there is a 2.5 second timeout on this, which will terminate the vend sequence with no loss of credit should blocker not go inactive. In blocker hold mode, due to the possibility of frauding certain machines, this timeout is not used. Therefore, if the start of the vend (as signalled by the removal of the blocker signal) does not occur, the following error state will result:

- Indicate host error on LED
- Inhibit all change giver functions
- Change giver will continually check if vend starts

Blocker Return

The end of vend condition on electro-mechanical hosts depends on the reset mode selected. In blocker hold mode, the end of vend is signalled by the return of the blocker signal. If this does not occur, the following error state will result:

- Indicate host error on LED
- Inhibit all change giver functions
- Change giver will continually check if host is re-enabled

Cashbox Full

An input is provided for a cashbox full sensor (provided by the host). The error handling for this sensor is:

- Indicate host error on LED
- Set cashbox full error flag (code 7 in error register)
- Disable all coin acceptance in normal mode
- Disable all coin acceptance in float mode
- Disable all coin acceptance in price teach mode
- Manual dispense is still allowed
- Terminal comms is still allowed
- Cashbox must be emptied to reset error

Bad Replies Received

Protocol A serial communications error handling is summarised below:

- Indicate host error on LED
- Suspend operation for 100mS
- Abort sequence and revert to sending status
- Disable all coin acceptance in normal mode
- Manual dispense is still allowed
- Allow return of credit
- Terminal comms is still allowed
- Change giver will continually check if failure rectified

No Response

- Indicate host error on LED
- Disable all coin acceptance in normal mode
- Manual dispense is still allowed
- Allow return of credit
- Terminal comms is still allowed
- Change giver will continually check if failure rectified

COIN HANDLING PROBLEMS

Full Sensor Failure

- Indicate change giver error on LED
- Disable routing to affected tube
- Set required code in full sensor error register
- Dispense from tube is still allowed
- On coin acceptance or dispense, change giver will check if failure rectified

Post Gate Strobe (PGS) Failure

- Indicate change giver error on LED
- Set PGS error flag (code 7 in full sensor error register)
- On coin acceptance or rejection, change giver will check if failure rectified

Tube Cassette Removal

- Indicate change giver error on LED
- Disable routing to tubes (all coins to cashbox)
- Set cassette removed error flag (code 4 in operational error register)
- Dispense is still allowed
- Signal exact change
- On coin acceptance or dispense, change giver will check if failure rectified

Home Sensor Failure

- Indicate change giver error on LED
- Disable use of affected tube
- Set required bit(s) in disabled tubes error register
- Signal exact change
- Manual dispense attempts from the tube are still allowed
- Error can be cleared by removing the source of the error and performing a manual dispense, or by using the MEI[®] Route Alpha 250 terminal.

Motor Failure / Jam

- Indicate change giver error on LED
- Disable use of affected tube(s)
- Set required codes in disabled tubes error register
- Signal exact change
- Manual dispense attempts from the tube are still allowed
- Error can be cleared by removing the source of the error and performing a manual dispense, or by using the MEI[®] Route Alpha 250 terminal.

ON-BOARD EEPROM PROBLEMS

Incorrect Configuration vsn. No.

If the configuration file version number in the on-board EEPROM does not match the version expected in the software, the following error handling applies:

- Set code 4 of EEPROM error register
- Indicate change giver error on LED
- No upload of EEPROM data will occur
- All coin acceptance will be disabled
- The keypad will be disabled, apart from the mode key
- Terminal comms. still allowed
- No save of data to EEPROM on power fail

- The configuration version number must be corrected. The error will then be cleared on change giver re-initialisation. This can be done by;
 - Clearing the error flag,
 - Updating the EEPROM version number,
 - Re-initialising.

EEPROM Corruption

If a corruption is detected in the EEPROM at upload time, the following error handling applies:

- Set code 0 - 1 of EEPROM error register
- Indicate change giver error on LED
- No upload of EEPROM data will occur
- All coin acceptance will be disabled
- The keypad will be disabled, apart from the mode key
- Terminal comms is still allowed
- No save of data to EEPROM on power fail

While a reset device error appears to clear the error, note that there will be no configuration data uploaded into RAM, and hence the change giver's operation will be indeterminate. After clearing the error, the checksum of the affected page should be corrected and the change giver re-initialised.

Write Timeout

If a timeout occurs when writing to the EEPROM, the following error handling applies:

- Set bit 7 of EEPROM error register
- Indicate change giver error on LED
- All coin acceptance will be disabled
- The keypad will remain enabled, with manual dispense still allowed
- Terminal comms is still allowed
- No save of data to EEPROM on power fail
- Change giver must be switched off to reset error.

AUDIT FEM PROBLEMS

Audit not initialised

If a FEM is present but has not be initialised, the following applies:

- Set code 5 in error register
- Indicate change giver error on LED
- No coin in / out events will be audited
- Vending is disabled
- Audit must be initialised to clear error.

Audit FEM corrupt

If a FEM is present but is corrupt, the following applies:

- Set code 2 in error register
- Indicate change giver error on LED
- Suspend all change giver operation apart from FIB comms
- Mode key still operates
- Corruption may self repair if power is cycled. If not, then FEM must be replaced.

Audit removed

If a FEM had been present but is now removed, the following applies:

- Set code 3 in register
- Indicate change giver error on LED
- Suspend all change giver operation apart from FIB comms
- Mode key still operates

Audit must be re-fitted and change giver re-initialised to clear error.

HOST INTELLIGENT INTERFACE(HI²) ERRORS

The HI² is the internal comms highway that handles all messages between the acceptor and the control board

HI² Error

If an error occurs in the HI² protocol stack the following error handling applies:

- Indicate change giver error on LED

- Set codes 2 / 3 in error register
- Will not allow the changegiver to enter float or teach modes.
- Coin acceptance inhibited
- Manual dispense is not allowed
- Terminal comms is still allowed (if access is permitted)
- Changegiver will continually check if failure rectified

MISCELLANEOUS ERRORS

Acceptor Initialising Error

If there is a failure to transfer over data between the acceptor and control board on power-up, the following error handling applies:

- Indicate changegiver error on LED
- Set code 1 in error register
- All coin acceptance will be disabled
- Manual dispense is still allowed
- Terminal comms is still allowed

While a reset device error appears to clear the error, note that the data for coin routing, inhibits, coin types, etc. may not have been correctly passed between the acceptor and the changegiver, and hence the changegiver's operation will be indeterminate. After clearing the cause of the error the changegiver should be re-initialised.

VIA MEI[®] ROUTE ALPHA 250 TERMINAL

With a MEI[®] Route Alpha 250 terminal you can re-configure any of the functions available for a particular product. The terminal is connected to the acceptor via a six way connector which plugs into the front of the acceptor.

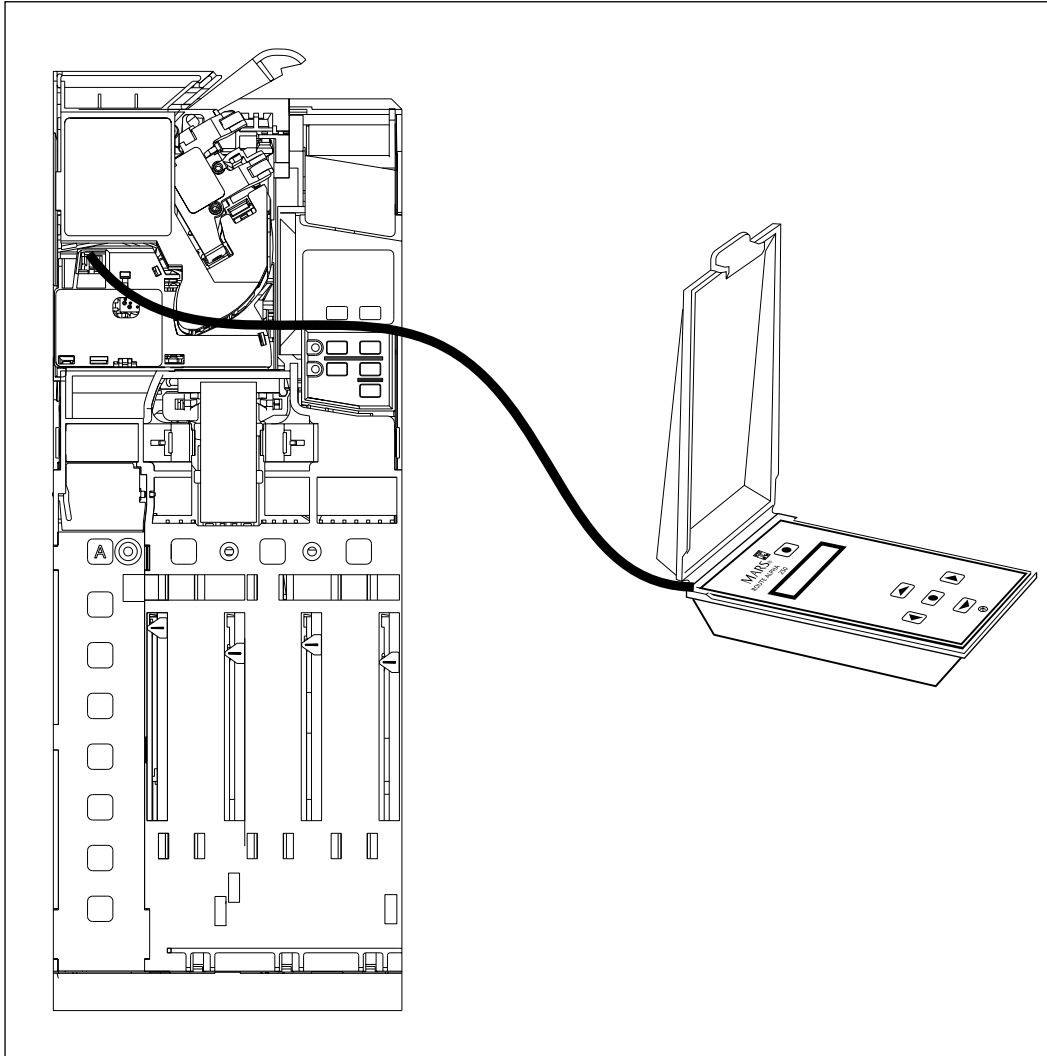

The terminal is used to check or change certain data which affects the way the changeover operates. The data is held in addresses. Each address has a unique number which identifies the feature you wish to read or change e.g. if you want to change from single vend to multi vend then you need to go to address number 226 and put in a 1 (single vend is a 0).

The following pages will explain how to access and change the data in certain addresses. At the end of this section there is a list of addresses and the relevant values. Particular reference should be made to the symbols in this section which indicate the applications (i.e. electromechanical, Executive, BDV and MDB) for which each address is appropriate.

KEY FUNCTIONS

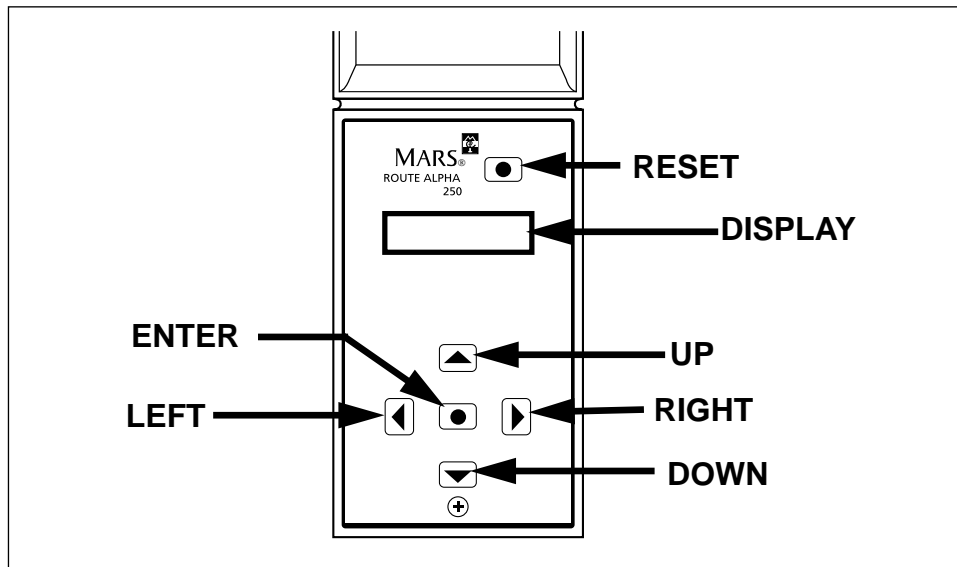

Reset Key: used to reset all modes and to initialise any settings that you have changed. If the reset key is pressed while an address is being updated then the address may not be updated. The reset key must be pressed to store the changes that you have made.

Up Key: used to increase the value displayed on the screen.

Down Key: used to decrease the value displayed on the screen.

Left Key: used to scroll the display to the left when a large number is being accessed that cannot be fully displayed on the screen.

Right Key: used to scroll the display to the right when a large number is being accessed that cannot be fully displayed on the screen.

Enter Key: used to change between the address and data displays.

Other Facilities of the Terminal

The terminal has several features to speed up its use. This includes the ability to scan at a higher speed with the keys auto repeating, to automatically roll over from its highest to lowest address and to inform the operator should a communication error occur.

Should you need to know which version numbers of the software is used in the changegiver the UP key is pressed while the terminal is in reset mode. The terminal will firstly display the acceptor HI² node address, if the UP key is pressed again the acceptor software version number will be displayed. Pressing the UP key again will display the acceptor eeprom number and if pressed again the acceptor configuration code. Pressing the RIGHT key will display the changegiver's software number

To return to normal operation press the RESET key.

Auto Repeating Keys

If either the UP or DOWN keys are kept pressed they automatically repeat. The repeat speed of the key increases the longer the key is held down.

Double Click Hotkeying

If a key is double clicked (pressed twice in quick succession) then this causes the address number to increment by a larger amount. e.g. if the user starts at address number 1 then double clicks the UP key, the address will jump to 40, double click again the address will jump to address 100 etc. This is useful as the addresses used for the change giver start at address 200. You can also double click the DOWN key to decrement by larger amounts.

USING THE TERMINAL

As soon as the terminal is connected to a change giver it powers up and interrogates the product.

The terminal display will clear and briefly show a message that indicates the version of software in the terminal. A display of [0 1.0] means software with a version number of 1.0 is fitted in the terminal.

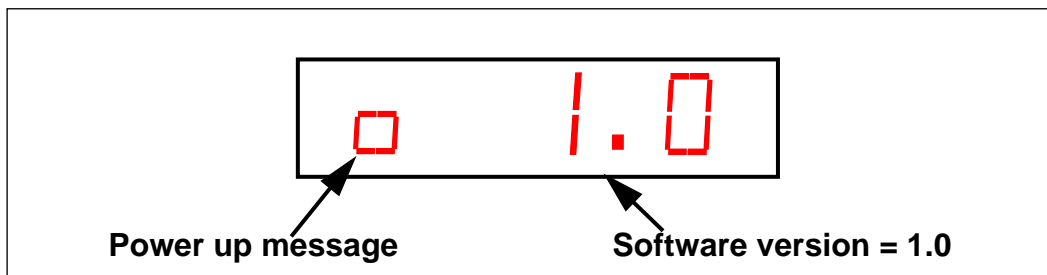

After a few seconds the display will show the number [1.] or [1.-]. Not all configuration items are applicable to every product but all the address values are shown on the display. If the value for the address is applicable to the product a dash will be present at the far right position on the display. The value can then be accessed and changed if required.

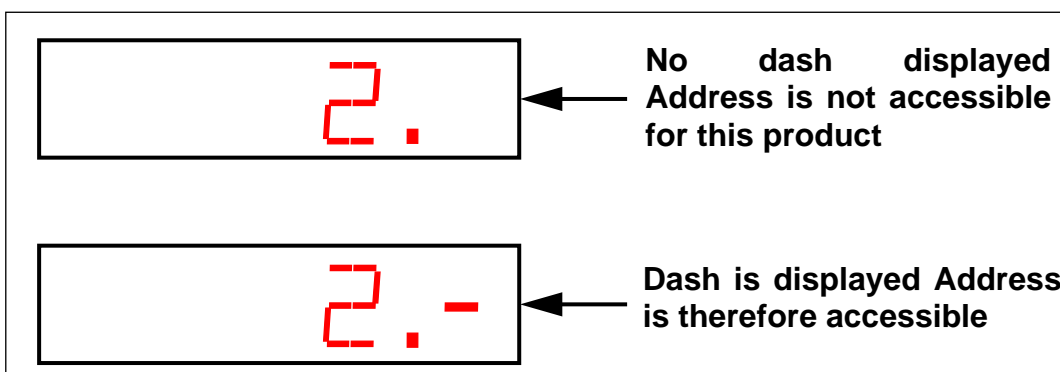

CashFlow[®] 560 change giver Applications Design Guide

The basic operation to alter the information held in an address is:

- 1 Connect the terminal to the CashFlow[®] product.
- 2 Wait for the terminal to power up correctly.
- 3 Select the address by using the UP and DOWN keys.
- 4 Examine the data by pressing the ENTER key.
- 5 Alter the data value by pressing the UP or DOWN keys until the new value has been reached.
- 6 Press the ENTER key to return to displaying addresses.
- 7 Press the RESET key to initialise the new value.

When the terminal is displaying values stored at addresses, no decimal point will be displayed.

If an error occurs with the communication between the terminal and the change giver the display will show an error message of four half height zeroes.

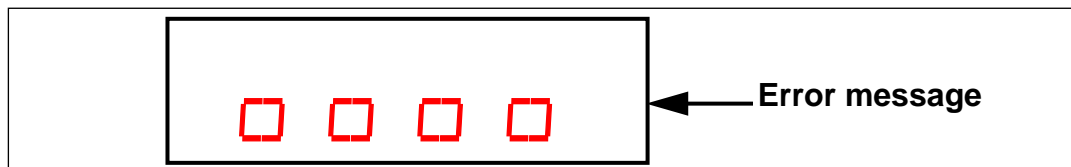

This message will stay on the display. Pressing the RESET key may clear the fault. The display will then revert to showing the current address. If the error occurred while updating an address then the value of that address should be checked as it may not have been updated correctly. If, after pressing the RESET key, the fault remains the error message will stay and you need to return the terminal for repair.

As the screen is capable of only displaying four digits at any one time the number displayed on the screen can be scrolled if it is greater than 9999 by using the LEFT and RIGHT keys. The left or rightmost digit will flash indicating an extra digit can be examined by use of the scrolling keys e.g. Value is 12345

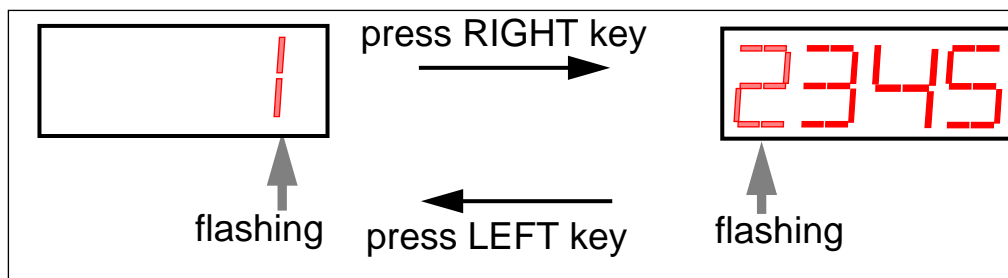

VISUAL AUDIT

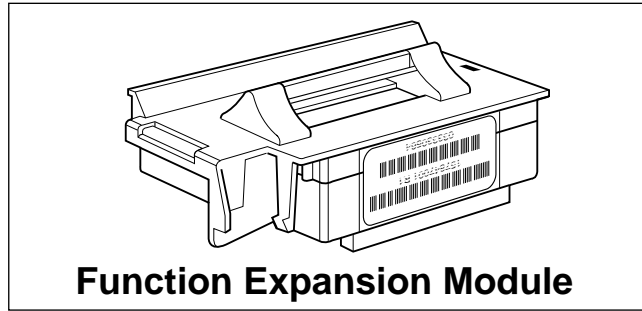

Visual Audit can be obtained, from the electro-mechanical and Executive products only, when an audit function expansion module (FEM) is installed as an accessory on to the Control PCB.

Data can be viewed with the use of a Route Alpha 250 terminal and the process for using this method follows below. Data is also available via a MEI[®] hand-held printer which can be accessed through an interface loom from the changeover, through a DEX/UCS jack-plug connected to a MEI[®] MEQ terminal, or from an infra-red optical interrogation point in the side of the machine, also using the MEQ terminal.

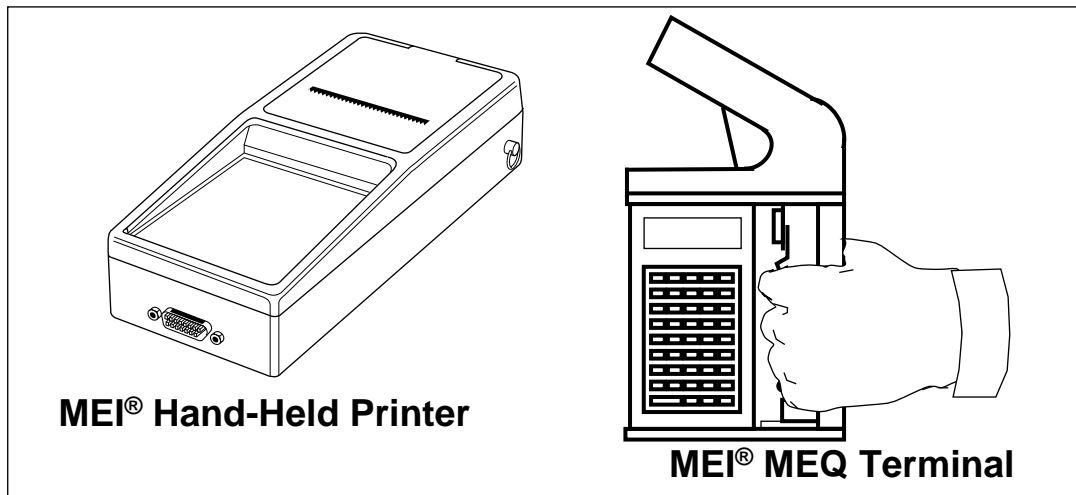

Visual Audit Interrogation

The Route Alpha 250 terminal display may not be able to show all details for each address. In order to ensure that all data has been read two quite separate addresses must be interrogated, one consisting of the least significant (ls) digits, and the other the most significant (ms) digits of the data.

To convert these two readings to a single audit value the (ms) value shown must be multiplied by 65536 and the (ls) figure added to the result.

The following process should be followed to use the Route Alpha 250 terminal for retrieval of data:

- Firstly select the required address using the Up and DOWN keys.
- Press ENTER to display the contents of the address. If the value exceeds four digits the LEFT and RIGHT keys are used to scroll the display left or right.

EXAMPLE. (To read the Cash In Tubes value)

- Select address 900
- Press ENTER to display the (ls) value, (e.g 54919)
- Press ENTER to return to address mode
- Press UP to select address 901
- Press ENTER to display the (ms) value, (e.g. 18)
- Multiply (ms) value by 65536 ($18 \times 65536 = 1179648$) and add (ls) value. ($1179648 + 54919 = 1234567$)

NOTES

All values are displayed on the terminal with no decimal point.

In order to reset the interim values address 999 must be used, ensuring that it is set to 9.

All values displayed will be in the range of 0 - 65535.

The relevant addresses for the Route Alpha 250 terminal in the following list are 900-999.

Route Alpha 250 Address Applications

The symbols below appear on the following pages together with most of the following Route Alpha 250 address numbers. They can be used as an aid to indicate which variety of product that each address is used with.

Where no symbol is used this address applies to 4 price electro-mechanical products only.

✕ = Address used with 4 price and Executive only

⊕ = Address used with 4 price, Executive and BDV only

▲ = Address used with 4 price, Executive, BDV and MDB

■ = Address used with 4 price and BDV only

✓ = Address used with Executive and BDV only

***** = Address used with BDV only

◆ = Address used with MDB only

CashFlow[®] 560 changeiver Applications Design Guide

Addresses and Values

The table below shows you the address of each item that can be re-configured and their possible values.

Address	Parameter	Range	Meaning
+ 21 - 32	Coin types 1 - 12	0-2	0 = coin 1 = value token 2 = vend token
+ 200	Maximum credit	0-65,535	maximum credit 4 price, maximum change BDV
+ 201-204	Prices 1 - 4	0-65,535	value of prices 1 - 4
X 205-225	Prices 5 - 25 (When audit FEM fitted only)	0-65,535	value of prices 5 - 25
+ 226	Single/Multivend	0 - 1	0 = single vend 1 = multivend
+ 227	Escrow return inhibit	0 - 1	0 = escrow allowed 1 = escrow inhibited
228	Reset mode (Electromech only)	0 - 4	0 = blocker reset 1 = delayed blocker reset (30ms) 2 = delayed blocker reset (200ms) 3 = blocker hold reset 4 = after escrow accept signal
▲ 229	Coin inhibit, coins 1-4 for multiple coin inhibit, add together e.g. 1 + 8 = 9 so coins 1 & 4 are inhibited	0 - 15	0 = no coins inhibited 1 = inhibit coin 1 2 = inhibit coin 2 4 = inhibit coin 3 8 = inhibit coin 4
▲ 230	Coin inhibit, coins 5-8	0 - 15	0 = no coins inhibited 1 = inhibit coin 5 2 = inhibit coin 6 4 = inhibit coin 7 8 = inhibit coin 8

CashFlow[®] 560 changegiver Applications Design Guide

Address	Parameter	Range	Meaning
▲ 231	Coin inhibit, coins 9 -12	0 -15	0 = no coins inhibited 1 = inhibit coin 9 2 = inhibit coin 10 4 = inhibit coin 11 8 = inhibit coin 12
⊕ 232	Exact change inhibit group Inhibit coins 1 - 4	0 -15	1 = coin 1 2 = coin 2 4 = coin 3 8 = coin 4
⊕ 233	Exact change inhibit group Inhibit coins 5 - 8	0 -15	1 = coin 5 2 = coin 6 4 = coin 7 8 = coin 8
⊕ 234	Exact change inhibit group Inhibit coins 9 - 12	0 -15	1 = coin 9 2 = coin 10 4 = coin 11 8 = coin 12
⊕ 235	Change delay	0 - 255	delay in 1 second steps 255 = infinite delay
⊕ 236	Exact change equation part1	0 - 15	1/2/4/8 = tubes A/B/C/D
⊕ 237	Exact change equation part 2	0 - 15	1/2/4/8 = tubes A/B/C/D
✓ 238	Price hold	0 - 1	0 = do not hold price 1 = hold price
⊕ 239	Price display options	0 -1	0 = do not display price 1 = display price
✓ 240	Coin scaling factor	0 - 250	
▲ 241	Decimal point position	0 - 3	decimal point position
⊕ 242	Overpay inhibit options	0 -1	0 = overpay allowed 1 = overpay Inhibited

CashFlow[®] 560 change giver Applications Design Guide

Address	Parameter	Range	Meaning
⊕ 243	Clear overpay inhibit options	0 - 1	0 = clear down allowed 1 = clear down inhibited
⊕ 244	Keypad inhibit options	0 - 1	0 = keypad enabled 1 = keypad inhibited
⊕ 245	Price teach inhibit options	0 - 1	0 = price teach allowed 1 = price teach inhibited
246	Fast sense options (Electromech only)	0 - 1	0 = normal 1 = fast sense
▲ 247	Auto tube inventory options (float down)	0 - 1	0 = float down disabled 1 = float down enabled
▲ 251-254	Tubes A - D float level options	0 - 255	number of coins in a tube to be floated to
▲ 261-264	Tubes A - D full count options	0 - 255	number of coins in a tube that activate the full sensor
▲ 271-274	Tubes A - D low count options	0 - 255	number of coins in a tube that activate the low sensor
▲ 281-284	Tubes A - D safe count options	0 - 7	minimum number of coins that must be left in a tube (this number is multiplied by 2 in the change giver)
▲ 291-294	1st coin type in tubes A - D (ref. addresses 21-32)	0 - 12	coin number 0 = no coin (taken from coinset label reading from left to right and top to bottom)
▲ 301-304	2nd coin type in tubes A - D (ref. addresses 21-32)	0 - 12	coin number, 0 = no coin
▲ 310	Value of coins in tubes READ ONLY	0-65,535	value of coins in all tubes
▲ 311-314	Tubes A - D current coin count READ ONLY	0 - 255	current number of coins in tube
▲ 321-332	value of coins 1 - 12	0-65,535	

CashFlow[®] 560 changeiver Applications Design Guide

Address	Parameter	Range	Meaning
▲ 340	Full sensor errors READ ONLY	0 - 255	tubes 1/2/4/8 = A/B/C/D 128 = Post gate strobe errors
▲ 341	Tube dis-abled data	0 - 31	tubes A/B/C/D READ ONLY
▲ 342	EEPROM errors (i) data READ ONLY	0 - 15	1 = errors in page 0 2 = errors in page 1 4 = corrupt audit FEM 8 = audit FEM removed
▲ 343	EEPROM errors (ii) data READ ONLY	0 - 15	1 = incorrect configuration version 2 = audit FEM present but not initialised 4= undefined 8 = internal write error
▲ 344	Operational errors (i) data READ ONLY	0 - 15	1 = coinset code error 2 = acceptor error 4 = HII hardware error 8 = HII transmit error
▲ 345	Operational errors (ii) data READ ONLY	0 - 15	1= coin cassette removed 2=protocol A receive error 4=protocol A transmit error 8 = cashbox full error
* 346	BDV errors (i) options	0 - 15	1 = audit timed out 2 = vmc timed out 4 = cpc timed out
* 347	BDV errors (ii) options	0 -15	1 = audit incompatible 2 = vmc incompatible 4 = cpc incompatible
▲ 349	Reset error flags options	0 - 1	0 = do not reset 1 = reset error flags
X 360	Audit module - VMC identification code	0-65,535	vending machine ID
X 361	Audit module - printout language options	0 - 4	0 = English 1 = French 2 = German 3 = Dutch 4 = Spanish

CashFlow[®] 560 change giver Applications Design Guide

Address	Parameter	Range	Meaning
✕ 362	Audit module - printout type options	0 - 2	0 = basic 1 = basic + interim vend report 2 = basic + interim vend + free vend report
✕ 363	Audit module - printout product limit	0 - 25	limit details on printout to first few specified price lines
✕ 364	Audit module - installation day	1 - 31	day of installation into the machine
✕ 365	Audit module - installation month	1 - 12	month of installation into the machine
✕ 366	Audit module - installation year	0 - 99	year of installation into the machine
* 380	Discount award options	0 - 9999	amount added to credit when the vended value exceeds the discount trigger
* 381	Discount trigger options	0 - 9999	if vended value exceeds this value then the award will be added to the system credit
* 382	Link Master ID	0 - 9999	ID code of link master node
* 383	Exact change offset (Used in conjunction with addresses 271-274)	0 - 15	additional setting allows a more advanced warning to be given of the exact change requirement
* 384	Max coin credit	0-65,535	maximum coin credit that can be accepted by the change giver
* 385	Audit unit is BDV	0 - 1	0 = audit unit is not BDV, 1 = audit unit is BDV
* 386	VMC unit BDV	0 - 1	0 = VMC is not BDV, 1 = VMC is BDV
* 387	Cashless payment controller (CPC) unit is BDV	0 - 1	0 = CPC is not BDV, 1 = CPC is BDV

CashFlow[®] 560 change giver Applications Design Guide

Address	Parameter	Range	Meaning
* 388	Card revaluation allowed	0 - 1	0 = revaluation not allowed, 1 = revaluation allowed
* 389	Audit unit fitted	0 - 1	0 = not fitted, 1 = audit unit fitted
* 390	VMC unit fitted	0 - 1	0 = not fitted, 1 = VMC fitted
* 391	CPC unit fitted	0 - 1	0 = not fitted, 1 = CPC fitted
* 392	BDV exact change equation	0 - 1	0 = normal, 1 = use BDV exact change equation
* 393	Audit initialisation required	0 - 1	0 = initialisation not required 1 = initialisation required
◆ 421-432	MDB change giver coin types 1 - 12	0 - 2	0 = coin 1 = token 2 = token
+ 600	Number of bills	0 -15	number of bill supported bt BVI
+ 601	Value of bill 1	0-65535	bill value 1 in real currency units. Bill values should be in equal/ascending order
+ 602	Value of bill 2	0-65535	bill value 2 in real currency units. Bill values should be in equal/ascending order
+ 603	Value of bill 3	0-65535	bill value 3 in real currency units. Bill values should be in equal/ascending order
+ 611	Bill scaling factor	0-65535	multiplier required to convert number of credit pulses received by the BVI to real currency units
+ 612	Bill default inhibit map	0 -7	value = sum of codes where 1/2/4 = lowest / middle / highest bill inhibit
+ 613	Bill exact change inhibit map	0 -7	value = sum of codes where 1/2/4 = lowest / middle / highest bill inhibit

CashFlow[®] 560 change giver Applications Design Guide

Address	Parameter	Range	Meaning
X 900	Cash in tubes (ls)	0-65535	visual audit
X 901	Cash in tubes (ms)	0-65535	visual audit
X 902	Value of cash sales interim (ls)	0-65535	visual audit
X 903	Value of cash sales interim (ms)	0-65535	visual audit
X 904	Number of cash sales interim (ls)	0-65535	visual audit
X 905	Number of cash sales interim (ms)	0-65535	visual audit
X 906	Value of cash in (ls)	0-65535	visual audit
X 907	Value of cash in (ms)	0-65535	visual audit
X 908	Cash to cash-box (ls)	0-65535	visual audit
X 909	Cash to cash-box (ms)	0-65535	visual audit
X 910	Cash to tubes (ls)	0-65535	visual audit
X 911	Cash to tubes (ms)	0-65535	visual audit
X 912	Dispensed cash (ls)	0-65535	visual audit
X 913	Dispensed cash (ms)	0-65535	visual audit
X 914	Manually invented cash (ls)	0-65535	visual audit
X 915	Manually invented cash (ms)	0-65535	visual audit
X 916	Overpay (ls)	0-65535	visual audit

CashFlow[®] 560 change giver Applications Design Guide

Address	Parameter	Range	Meaning
X 917	Overpay (ms)	0-65535	visual audit
X 918	Exact change vend value (ls)	0-65535	visual audit
X 919	Exact change vend value (ms)	0-65535	visual audit
X 920	Value of cash manually filled (ls)	0-65535	visual audit
X 921	Value of cash manually filled (ms)	0-65535	visual audit
X 922	Value of free sales interim (ls)	0-65535	visual audit
X 923	Value of free sales interim (ms)	0-65535	visual audit
X 924	Number of free sales interim (ls)	0-65535	visual audit
X 925	Number of free sales interim (ms)	0-65535	visual audit
X 926	Printout number (ls)	0-65535	visual audit
X 927	Printout number (ms)	0-65535	visual audit
X 928	Last printout number (ls)	0-65535	visual audit
X 929	Last printout number (ms)	0-65535	visual audit
X 930	Value of cash sales total (ls)	0-65535	visual audit
X 931	Value of cash sales total (ms)	0-65535	visual audit
X 932	Number of cash sales total (ls)	0-65535	visual audit
X 933	Number of cash sales total (ms)	0-65535	visual audit

CashFlow[®] 560 change giver Applications Design Guide

Address	Parameter	Range	Meaning
X 934	Value of free sales total (ls)	0-65535	visual audit
X 935	Value of free sales total (ms)	0-65535	visual audit
X 936	Number of free sales total (ls)	0-65535	visual audit
X 937	Number of free sales total (ms)	0-65535	visual audit
X 938	Value of bills in total (ls)	0-65535	visual audit (when used with Bill Validator Interface)
X 939	Value of bills in total (ms)	0-65535	visual audit (when used with Bill Validator Interface)
X 940	Interim value of bills (ls)	0-65535	visual audit (when used with Bill Validator Interface)
X 941	Interim value of bills (ms)	0-65535	visual audit (when used with Bill Validator Interface)
X 942	Value of vend token sales (ls)	0-65535	visual audit
X 943	Value of vend token sales (ms)	0-65535	visual audit
X 946-966 (Evens only)	Interim of products 0-10 (ls)	0-65535	visual audit
X 947-967 (Odds only)	Interim of products 0-10 (ms)	0-65535	visual audit
999	Interim reset address	0-65535	must be set to 9 to cause interims to be reset

DIAGNOSING TERMINAL PROBLEMS

SYMPTON	CAUSE	SOLUTION
Terminal displays an error message at power up	Communications error	Press RESET
Terminal displays an error message when changing from address to data mode or vice versa	Communications error between terminal and product or the terminal does not recognise the product it has been connected to	Repeat last operation
Terminal powers up correctly but no addresses are accessible	The product is not compatible with the terminal	Requires a different terminal/ software
Terminal does not power up	Bad connections or Faulty cable	Check connections at either end of lead. Replace lead
Terminal powers up but one of the keys does not work	Faulty key	Use the self test feature. If the key is faulty send unit for repair
Non standard characters printed on display	Faulty Route Alpha 250 terminal	Send unit for repair

Testing the Terminal

It is possible to test all the features of the terminal itself by putting the unit into a special test mode. To enter the test mode hold the ENTER key pressed when powering the unit up. The display will initially show three digits indicating the result of an automatic on board test. The display format is:

[<BUSY state> <DATA state> <AUTO TEST result>] where
<BUSY state> = current state of BUSY line, 0 = low, 1 = high
<DATA state> = current state of DATA line, 0 =low, 1=high
<AUTO TEST result> = result of automatic test

0 = Pass

1 = BUSY line error

2 = DATA line error

3 = BUSY and DATA line errors

Pressing the ENTER key activates the next stage of test.

The LCD is tested by displaying a pattern of four identical digits on the display. The digits alter every 1/2 second and the display should be examined to check all the digits are formed correctly.

Display will show:

[0000], [1111], [2222], [3333], [4444], [5555], [6666], [7777], [8888],
[9999], [----], [oooo], [], [.....].

Pressing the ENTER key activates the next stage of test.

The terminal keys are checked next. A single number is shown on the display indicating what key was pressed last. Display shows:

- [0] No key pressed
- [1] UP key pressed
- [2] RIGHT pressed
- [3] DOWN key pressed
- [4] LEFT key pressed
- [5] ENTER key pressed

This is the last test and the RESET key must be pressed to restart the terminal in normal operational mode.

ENVIRONMENTAL PERFORMANCE

Products are available to meet the following environmental specification.

TEMPERATURE RANGE

Working ambient	- 15 to 60°C
Max rate of change	15°C/hr non condensing
Storage	-40 to + 65°C
Solar radiation	Max. working ambient applies

HUMIDITY

Operational	Worst case up to 90% RH, non condensing at 43°C
Storage	Worst case up to 95% RH, non condensing at 65°C

VIBRATION

Operational - units will not be damaged by these conditions:

Vibration (through machine mounting)	0.25g at 5 to 500 Hz. Intermittent over the unit's life. Refer to BS2011: part 2.1 Fc:1983
--------------------------------------	---

INSTALLATION

To ensure that the change giver operates correctly it must be mounted so that it hangs within $\pm 2^\circ$ of vertical from both front and side elevations.

The reject lever must have a minimum 3mm clearance from the machine reject mechanism when installed.

The amount of travel for the coin mechanism's reject lever when engaged should normally be between 12-18mm. It should not be forced beyond this point as there is a danger of the reject lever bottoming out and damage being caused.

TRANSPORTATION

Units in the packed state will not sustain any physical damage under these conditions:

Shock	Half sine, 30g shock, 18ms dur. Refer to BS 2011: part 2.1 Ea: 1977
Bump	1000 bumps 6ms duration at 25g. Refer to BS 2011: part 2.1 Eb: 1977
Free Fall	1000mm fall onto packing faces. Refer to BS 2011: part 2.1 Ed: 1977
Crush	Neatly stacked units of the same type may be stacked to a height of 2 metres.

LIQUIDS

Water

The units inclusive of PCBs will be splash protected.

The coin entry encourages excess water towards the reject path and the front of the product out of the coin path. Coin stall under these conditions is minimised.

The above should in no way be interpreted as a specification capable of operating at 100% RH.

Salt Water

As above.

Prolonged exposure in a salt laden atmosphere will lead to PCB corrosion damage.

Other Liquids

This includes: dilute carbonic acid, dilute citric acid, carbonated drinks, beer, tea, coffee, chocolate, soup, syrup, sugar residue and uric acid.

- Certain beverages and the dilute acids may cause similar effects to salt water if they contact the PCB's.
- Wet performance will be similar to that described for water.
- Liquids which leave a residue on drying which affects the passage of coins could cause malfunction.

VOLTAGE

Supply

The unit will operate to specification on the following supply voltages:

46 - 64 Hz AC RMS.

- 20.4 - 26.4 V RMS
- 87 - 121 V RMS
- 95 - 132 V RMS
- 187 - 242 V RMS
- 212 - 264 V RMS
- 207 - 244 V RMS* single transformer profile

Note: For each of the above voltage waveforms the peak voltage must be $\sqrt{2}$ V RMS

DC (BDV)

Absolute maximum voltage - 40 volts DC. Minimum voltage - 22 volts average DC (with up to 7 volts peak to peak ripple 94 -126 Hz.)

DC (MDB)

Absolute maximum voltage - 44 volts DC (Typically 34 volts)

Minimum voltage - 18.5 volts average DC (with up to 7 volts peak to peak ripple 94 -126 Hz.)

NOTE. During the life of the defined products, there will be a requirement for European equipment (whole vending machine) to operate at 230 V +6%, -10%. Most countries except UK have agreed to this change. The 240V transformer design is such that this change can be accommodated.

VOLTAGE TRANSIENTS

Minimum performance can be regarded as that stated under the section on susceptibility.

The unit will perform to criteria A for supply loss (100%) of up to two cycles.

For supply loss of greater than 2 cycles then performance criteria B applies.

For DC (BDV / MDB) units, voltage transients that go below the minimum average level - peak ripple voltage, will cause variance to performance criteria B. (i.e. loss of credit).

SAFETY CLASSIFICATIONS

CLASSIFICATION

The product will comply with:

- UL 756 “Coin and currency changers and actuators”
- IEC 335, 3rd Edition “Safety of household and similar electrical appliances”

PARTITIONS

All of the following lines are assumed to be at mains potential (live parts at hazardous voltage).

Mains input (live & neutral)

Exact change output

Price sense inputs

Price outputs

Blocker (vend start) input

Escrow accept input

Price line common input

Safety line output

All of the following lines, and any other circuits accessible without the removal of any covers using a tool are assumed to be unearthed accessible SELV circuits as defined in IEC 335.

Protocol A current loop

MEI terminal link

Credit display

Cashbox full connector

Acceptor serial link

Credit relay coil output

SAFETY INSULATION

Safety insulation is provided between:

- a) All operator points of contact without tool access and hazardous voltages
- b) SELV circuits and hazardous voltages

Safety insulation (as defined above) is provided as follows:

- Clearance through air ≥ 8.0 mm
- Creepage over insulation surface ≥ 8.0 mm
- Thickness through insulation (except for cables)
 - a) Accessible reinforced insulation ≥ 2.0 mm
 - b) Basic insulation ≥ 1.0 mm
- Dielectric strength of reinforced insulation: 3750 VAC RMS for 1 minute
- Dielectric strength of supplementary insulation: 2750 VAC RMS for 1 minute

Insulation is provided between poles of the supply input (live & neutral) and to other hazardous voltages as follows:

- Clearance through air before fuse ≥ 2.5 mm
- Clearance through air after fuse ≥ 1.0 mm
- Creepage over insulation surface before fuse ≥ 3.0 mm
- Creepage over insulation surface after fuse ≥ 1.0 mm
- Dielectric strength over basic insulation ≥ 1250 VAC RMS for 1 minute

ENERGY STORAGE

The maximum energy stored in the product's smoothing capacitor will be less than 8.6 Joules at maximum input voltage and no load.

FLAMMABILITY

All major plastic parts are moulded in materials with a flammability rating of UL 94 V-2 or better. Small parts which do not form part of the fire containment enclosure, or which are not located close (< 13.0 mm) to live (hazardous) parts, may be moulded from a material with a flammability rating of UL 94 V-HB.

ELECTRO-MECHANICAL AND MAINS INPUT RATINGS

- Input: (line and neutral) fused neutral only 1.6A thermal
Fault rating 3.5A
- Exact change fused neutral only 1.6a thermal
Load rating 0.5A
Fault rating 3.5A
- Price line common
- Price lines, safety line fused PLC only 3.15A fast
Load rating 2.6A
Fault rating 7A

The product will satisfy the requirements of class 2 equipment as defined in IEC 950.

MECHANICAL PARTS

The product does not contain mechanically moving parts, or sharp edges, which can present a hazard in normal use.

COMPATIBILITY

The CashFlow[®] 560 product range is compatible with the majority of modern vending machines. It is a plug compatible replacement for the previous MS1500, MS1600, ME1600 and ME1900 series of change givers. The options currently available are;

- CashFlow[®] 560 - 4 price - A four price electromechanical change giver

Interfaces are provided for a credit display if required on the above variant.

- CashFlow[®] 560 - Executive - change giver with an electronic Protocol A serial interface
- CashFlow[®] 560 - BDV - change giver with an electronic BDV serial interface
- CashFlow[®] 560 - MDB - change giver with an electronic MDB serial interface

The looms fitted to the CashFlow[®] 560 products have a range of connectors and pinouts to be fully compatible with existing machine wiring. The table below shows the new CashFlow[®] looms and the old interface looms which they replace.

CashFlow[®] Machine Loom No.	Replaces	Serial (Protocol A)	BDV	MDB	Electro mechanical	No. of Price Lines
T1	EA	✓				N/a
T2	E05,EB		✓			N/a
T3	B32,FI, F16				✓	1
T4	FF,B12,F 15, F26				✓	4
T5	FB,B03,B 62 F03,F10, F35				✓	4
T6	FJ, F02, F27, B02				✓	3

CashFlow® 560 changeover Applications Design Guide

CashFlow® Machine Loom No.	Replaces	Serial (Protocol A)	BDV	MDB	Electro mechanical	No. of Price Lines
T7	FA, No credit relay	(Gen. purpose loom) Adaptor looms 3, 4, 5 and 6 are used in conjunction with this loom				
T8	FD,B74,F 01				✓	4
T9	FC,B60,F 08,F33				✓	4
T11	FE,F12				✓	4
T12	FG,F44				✓	4
T13	--				✓	4
Machine Loom 165972002	FF, F26 Adaptor				✓	4
MDB				✓		

BILL VALIDATOR INTERFACE

The electro-mechanical and Executive products can be used in conjunction with a bill validator. To do so the following elements must be present before commencing an installation:

- CashFlow® changegiver product
- Robust Terminal cable
- Bill validator cable/s to host power
- Bill validator interface
- BVI to bill validator cable
- MEI® Route Alpha 250 terminal

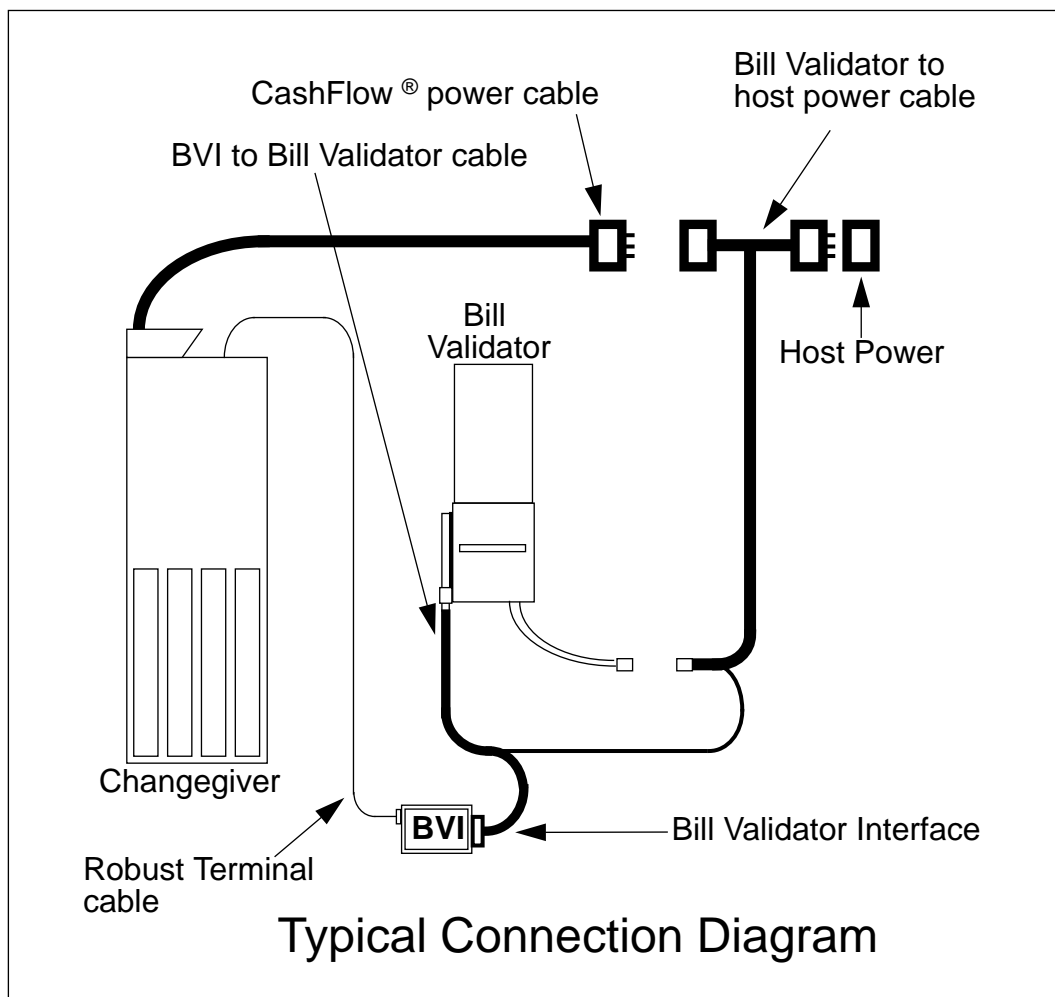

CashFlow[®] 560 changegiver Applications Design Guide

The successful connection of the changegiver and the bill validator has two phases, that of installing the Robust Terminal cable into the changegiver, and the connection of that cable to the bill validator.

To install the Robust Terminal cable into the changegiver the following process must be followed, having first dis-connected the CashFlow[®] product's power plug:

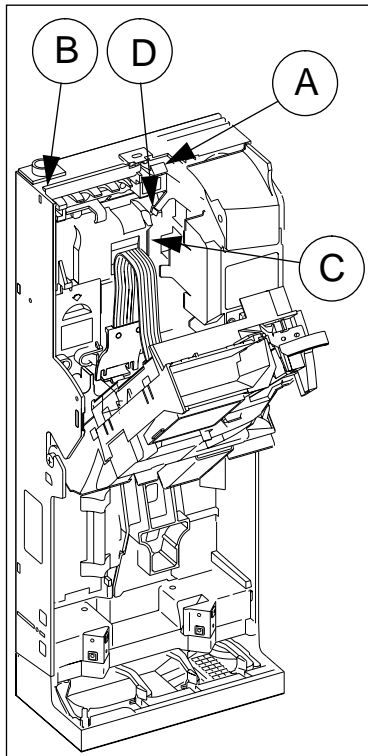

- a) Remove the coin storage cassette from the front of the product by squeezing the blue tabs in the centre of the cassette.
- b) Release the acceptor module and tilt forward by pressing the blue retaining catch down with a fine screwdriver at point A.
- c) Dis-engage the cable restraint at point B by gently pulling the side of the channel outwards. Remove the right-most grommet. Connect the 6-pin end of the Robust Terminal cable into CON 16 on the control board, located at point C.
- d) Feed the cable towards the point where the grommet was removed, ensuring that it lays flat and is behind the cable retainer at point D. Insert the cable grommet and re-engage the cable restraint.

Replace the acceptor module and coin storage cassette.

The next step requires the use of the correct interface cable, the part numbers of which are shown in the following table

Interface Cable Options

Host Plug Type BVI Type	8 - way Jones (T3, T4, T6)	15 way Molex (T4, T10) 24v Typ.)	Separate Power Options		
			9 - way Mate 'n lock (110v Typ.)	Low Level only	Flying leads
VFM3	172040002	172048003	179042001		
GL2C	181076002	181074003	181078001		
CBV	170944003	170942004	170946002	170948001	
Verival					181227001

To connect the bill validator to the change giver:

- a) Ensure that the required interface cable is available, confirming this with the table on the previous page. Each cable should have its part number on a label attached to it.
- b) Connect the Robust Terminal cable to the 10-pin socket on the left hand side of the BVI (label side up). At no time should the MEI[®] Route Alpha 250 terminal connector be attached to this socket.
- c) Connect the interface cable to the 34-pin socket on the right hand side of the BVI. The other ends of the cable attach to the bill validator and host power socket. At the bill validator end of this cable secure the black screen (with solder tag) to a bill validator mounting bolt.
- d) Where the bill validator and the change giver have different supply voltages you are advised to consult with your MEI regional office technical support team for advice regarding change giver loom options.
- e) Apply power from the host machine and set up the system, through the change giver, using the MEI[®] Route Alpha 250 terminal. Reference should be made to the terminal address data on the BVI label.
An explanation of the symbols shown on the BVI label is given on the next page.
- f) Set the change giver to maximum credit enabling the highest value bill to be accepted (using Route Alpha 250 terminal address 200). Ensure that there is sufficient change in the tubes to enable bill acceptance.
- g) Ensure that all of the bill validator switches are correctly set.

NOTE: When installing a GL2C type bill validator any enable switches MUST be set to OFF.

BVI Label Explanations

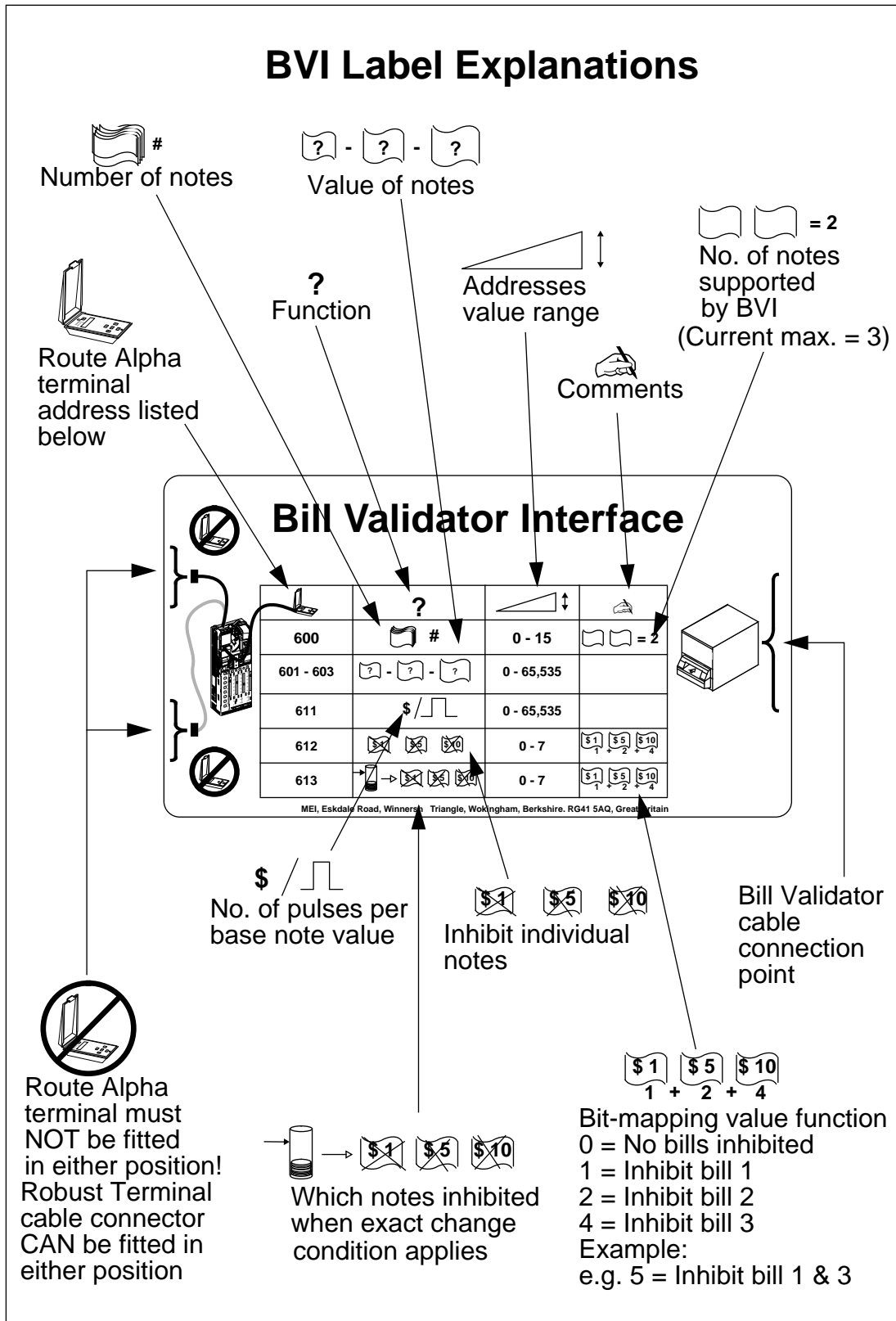

MEI OFFICES

WWW.MEIGROUP.COM

INDEX

A

Accept Gate Module	6, 7
Acceptor Initialising Error	47
Acceptor Module	2, 6, 7, 16, 75
Appendix	84
Audit FEM Problems	46
Automatic Tube Float	38

B

Best Change Calculation	15
Bill Validator Cable	74
Bill Validator Interface	74, 75, 76
Bill Validator Label	77
Bill Validator Switches	76
Blocker	11
Blocker Removal	41
Blocker Reset	28, 29, 30, 31
Blocker Return	42
Blocker Signal	31, 32
BVI Label	76

C

Cancelling Credit	33
Cashbox Error	14
Cashbox Full	42
Cashbox Routing	10
Change Payback	15
Coin Acceptance	13
Coin Count Calibration	18, 19
Coin Deflector	6
Coin Exit Chuting	13
Coin Handling Problems	43
Coin Routing	13, 14
Coin Storage Cassette	2, 8, 10, 17, 19, 20, 75
Coin Storage Tubes	2, 8, 10, 15
Coin Tube Prisms	10
Compatibility	2
Control Board	2, 7
Control Board Loom	8

Credit	15
Credit Relay Drive	25
D	
Dangerous Environments	1
Default Inhibits	13
Designators	10
Discriminator	6
Displaying Float Value	34
Displaying Vend Price	34
Dispense Arms	20
Dispenser Module	2, 8
Dispenser Motor Failure / Jam	44
Displaying Credit	33
Displaying Price Teach Credit	34
Displaying Tube Value	40
Disposal Of Product	1
Double Click Hotkeying	50
E	
EEPROM Problems	44, 45
Electrical Interfaces	22
Electro Magnetic Compatibility	68
Electro Mechanical Interface	25
Electromechanical and Mains Input Ratings	71
Electro-Mechanical Interface	23, 24, 25
Energy Storage	70
Environmental Performance	66
Escrow Accept	31, 32
Exact Change Inhibits	13
Exact Change Light	10, 11, 12
Exact Change Output	25
Exact Change Signal	13
F	
FIB Errors	46
Flammability	70
Flight Deck	6
Flight Deck Lid	6, 7
Float Down Mode	38, 39
Float Indicators	10
Float Mode	13
Float Up	38
Full Level Sensors	16

Full Sensor Failure	43
G	
Global Coin Inhibit	14
H	
Hinge Spring	7
Home Sensors	20
Home Sensors Failure	44
Homing Dispenser	40
Host Inhibited	41
Host Machine Problems	41
Humidity	66
I	
Inhibit Inputs	32
Interface Compatibility	72
Internal Diagnostics And Errors	41
K	
Keypad	2, 8
Keypad Functions	36, 37, 38, 40
L	
LED Usage	37
Lid Arm	6
Liquids	67
Low Level Sensors	16
M	
Man Machine Interface	21, 36
Manual Coin Dispense	37
MEI OFFICES	78
MEI [®] Route Alpha 250 Terminal	74
MEI [®] Route Alpha 250 Terminal	4, 7, 35, 48, 76
Maximum Allowed Credit	13
Maximum Level	14
Mechanical Parts	71
Miscellaneous Errors	47
O	
Operating Voltage	1, 32
Overpay Inhibit	13
P	
Post Gate Strobe Failure	43
Power Consumption / Rating	35

Power On Indicator	34
Price Line Common	25
Price Line Outputs	25
Price Teach Mode	13, 39, 40
Product Interfaces	21
Product Operation	5
Product Overview	2, 3
Protocol A Errors	42, 43
R	
Reject Lever	13
Resetting Tube Counts	38, 39
Robust Terminal Cable	74, 75, 76
S	
Safety	1, 69
Safety Insulation	70
Safety Line	25
Sense Input Timing	27
Sensor Errors	18
Separator Module	2, 7
Serial Interface	22
Single/Multi Vend	27
Spine	2, 7
T	
Temperature Range	66
Terminal Addresses	55
Terminal Connector	35
Terminal Fault Finding	64
Terminal Key Functions	49, 50, 51
Terminal Testing Procedure	65
Token	14
Top Level Sensor	10
Transformer Assembly	2, 8
Transportation	67
Tube Cassette Removal	43
Tube Full Sensors	14, 17
Tube Sensors	16
V	
Vend Finished Signal	28
Vend Start Signal	27, 28, 32

CashFlow[®] 560 changeover Applications Design Guide

Vibration	66
Voltage Range	35
Voltage Transients	68
Voltage (supply)	68

APPENDIX

INTERFACE DRAWING

Mechanical interface drawing number 148324001, consisting of 3 separate sheets, shows details of the following:

- Reject mechanism & coin routes
- Mounting details
- Space envelope

CashFlow[®] 560 changegiver Applications Design Guide

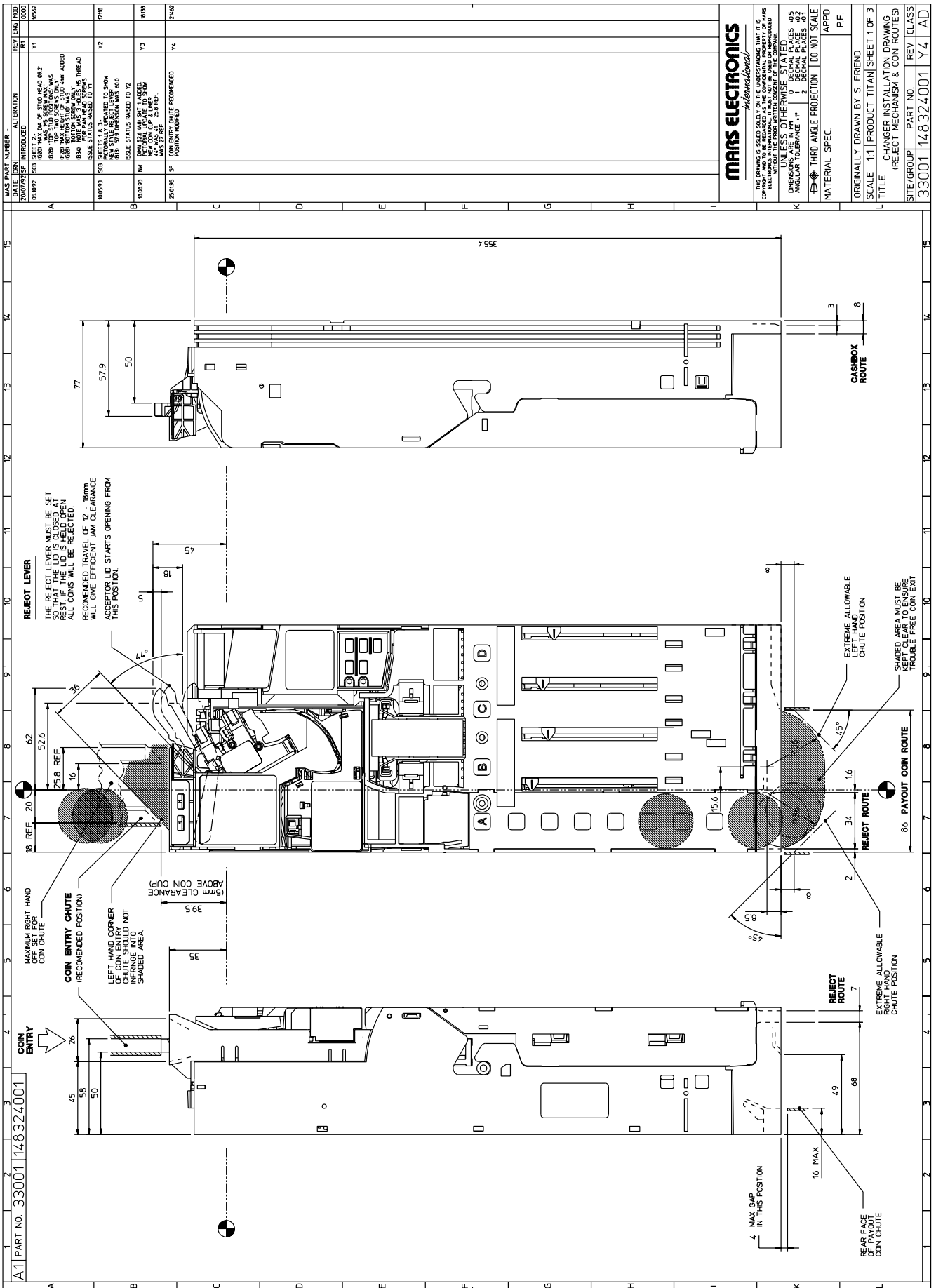

WAS PART NUMBER	REVISION	DATE	BY	CHKD
33001	1	11/83	RT	RT
33001	2	11/83	RT	RT
33001	3	11/83	RT	RT
33001	4	11/83	RT	RT

NO	DESCRIPTION	DATE	BY	CHKD
01	INTRODUCED	11/83	RT	RT
02	ISSUE STATUS RAISED TO 12	11/83	RT	RT
03	ISSUE STATUS RAISED TO 12	11/83	RT	RT
04	ISSUE STATUS RAISED TO 12	11/83	RT	RT
05	ISSUE STATUS RAISED TO 12	11/83	RT	RT
06	ISSUE STATUS RAISED TO 12	11/83	RT	RT
07	ISSUE STATUS RAISED TO 12	11/83	RT	RT
08	ISSUE STATUS RAISED TO 12	11/83	RT	RT
09	ISSUE STATUS RAISED TO 12	11/83	RT	RT
10	ISSUE STATUS RAISED TO 12	11/83	RT	RT
11	ISSUE STATUS RAISED TO 12	11/83	RT	RT
12	ISSUE STATUS RAISED TO 12	11/83	RT	RT
13	ISSUE STATUS RAISED TO 12	11/83	RT	RT
14	ISSUE STATUS RAISED TO 12	11/83	RT	RT
15	ISSUE STATUS RAISED TO 12	11/83	RT	RT
16	ISSUE STATUS RAISED TO 12	11/83	RT	RT
17	ISSUE STATUS RAISED TO 12	11/83	RT	RT
18	ISSUE STATUS RAISED TO 12	11/83	RT	RT
19	ISSUE STATUS RAISED TO 12	11/83	RT	RT
20	ISSUE STATUS RAISED TO 12	11/83	RT	RT
21	ISSUE STATUS RAISED TO 12	11/83	RT	RT
22	ISSUE STATUS RAISED TO 12	11/83	RT	RT
23	ISSUE STATUS RAISED TO 12	11/83	RT	RT
24	ISSUE STATUS RAISED TO 12	11/83	RT	RT
25	ISSUE STATUS RAISED TO 12	11/83	RT	RT
26	ISSUE STATUS RAISED TO 12	11/83	RT	RT
27	ISSUE STATUS RAISED TO 12	11/83	RT	RT
28	ISSUE STATUS RAISED TO 12	11/83	RT	RT
29	ISSUE STATUS RAISED TO 12	11/83	RT	RT
30	ISSUE STATUS RAISED TO 12	11/83	RT	RT
31	ISSUE STATUS RAISED TO 12	11/83	RT	RT
32	ISSUE STATUS RAISED TO 12	11/83	RT	RT
33	ISSUE STATUS RAISED TO 12	11/83	RT	RT
34	ISSUE STATUS RAISED TO 12	11/83	RT	RT
35	ISSUE STATUS RAISED TO 12	11/83	RT	RT
36	ISSUE STATUS RAISED TO 12	11/83	RT	RT
37	ISSUE STATUS RAISED TO 12	11/83	RT	RT
38	ISSUE STATUS RAISED TO 12	11/83	RT	RT
39	ISSUE STATUS RAISED TO 12	11/83	RT	RT
40	ISSUE STATUS RAISED TO 12	11/83	RT	RT
41	ISSUE STATUS RAISED TO 12	11/83	RT	RT
42	ISSUE STATUS RAISED TO 12	11/83	RT	RT
43	ISSUE STATUS RAISED TO 12	11/83	RT	RT
44	ISSUE STATUS RAISED TO 12	11/83	RT	RT
45	ISSUE STATUS RAISED TO 12	11/83	RT	RT
46	ISSUE STATUS RAISED TO 12	11/83	RT	RT
47	ISSUE STATUS RAISED TO 12	11/83	RT	RT
48	ISSUE STATUS RAISED TO 12	11/83	RT	RT
49	ISSUE STATUS RAISED TO 12	11/83	RT	RT
50	ISSUE STATUS RAISED TO 12	11/83	RT	RT
51	ISSUE STATUS RAISED TO 12	11/83	RT	RT
52	ISSUE STATUS RAISED TO 12	11/83	RT	RT
53	ISSUE STATUS RAISED TO 12	11/83	RT	RT
54	ISSUE STATUS RAISED TO 12	11/83	RT	RT
55	ISSUE STATUS RAISED TO 12	11/83	RT	RT
56	ISSUE STATUS RAISED TO 12	11/83	RT	RT
57	ISSUE STATUS RAISED TO 12	11/83	RT	RT
58	ISSUE STATUS RAISED TO 12	11/83	RT	RT
59	ISSUE STATUS RAISED TO 12	11/83	RT	RT
60	ISSUE STATUS RAISED TO 12	11/83	RT	RT
61	ISSUE STATUS RAISED TO 12	11/83	RT	RT
62	ISSUE STATUS RAISED TO 12	11/83	RT	RT
63	ISSUE STATUS RAISED TO 12	11/83	RT	RT
64	ISSUE STATUS RAISED TO 12	11/83	RT	RT
65	ISSUE STATUS RAISED TO 12	11/83	RT	RT
66	ISSUE STATUS RAISED TO 12	11/83	RT	RT
67	ISSUE STATUS RAISED TO 12	11/83	RT	RT
68	ISSUE STATUS RAISED TO 12	11/83	RT	RT
69	ISSUE STATUS RAISED TO 12	11/83	RT	RT
70	ISSUE STATUS RAISED TO 12	11/83	RT	RT
71	ISSUE STATUS RAISED TO 12	11/83	RT	RT
72	ISSUE STATUS RAISED TO 12	11/83	RT	RT
73	ISSUE STATUS RAISED TO 12	11/83	RT	RT
74	ISSUE STATUS RAISED TO 12	11/83	RT	RT
75	ISSUE STATUS RAISED TO 12	11/83	RT	RT
76	ISSUE STATUS RAISED TO 12	11/83	RT	RT
77	ISSUE STATUS RAISED TO 12	11/83	RT	RT
78	ISSUE STATUS RAISED TO 12	11/83	RT	RT
79	ISSUE STATUS RAISED TO 12	11/83	RT	RT
80	ISSUE STATUS RAISED TO 12	11/83	RT	RT
81	ISSUE STATUS RAISED TO 12	11/83	RT	RT
82	ISSUE STATUS RAISED TO 12	11/83	RT	RT
83	ISSUE STATUS RAISED TO 12	11/83	RT	RT
84	ISSUE STATUS RAISED TO 12	11/83	RT	RT
85	ISSUE STATUS RAISED TO 12	11/83	RT	RT
86	ISSUE STATUS RAISED TO 12	11/83	RT	RT
87	ISSUE STATUS RAISED TO 12	11/83	RT	RT
88	ISSUE STATUS RAISED TO 12	11/83	RT	RT
89	ISSUE STATUS RAISED TO 12	11/83	RT	RT
90	ISSUE STATUS RAISED TO 12	11/83	RT	RT
91	ISSUE STATUS RAISED TO 12	11/83	RT	RT
92	ISSUE STATUS RAISED TO 12	11/83	RT	RT
93	ISSUE STATUS RAISED TO 12	11/83	RT	RT
94	ISSUE STATUS RAISED TO 12	11/83	RT	RT
95	ISSUE STATUS RAISED TO 12	11/83	RT	RT
96	ISSUE STATUS RAISED TO 12	11/83	RT	RT
97	ISSUE STATUS RAISED TO 12	11/83	RT	RT
98	ISSUE STATUS RAISED TO 12	11/83	RT	RT
99	ISSUE STATUS RAISED TO 12	11/83	RT	RT
100	ISSUE STATUS RAISED TO 12	11/83	RT	RT

MARS ELECTRONICS
Subsidiary

THIS DRAWING IS ISSUED SOLELY ON THE UNDERSTANDING THAT IT IS THE PROPERTY OF MARS ELECTRONICS AND IS NOT TO BE REPRODUCED OR TRANSMITTED IN ANY FORM OR BY ANY MEANS, WITHOUT THE WRITTEN CONSENT OF THE COMPANY.

UNLESS OTHERWISE SPECIFIED, DIMENSIONS ARE IN MILLIMETERS. DIMENSIONS IN PARENTHESES ARE IN INCHES. DECIMAL PLACES - 05 ANGULAR TOLERANCE 1° 1' 0" DECIMAL PLACES - 02 ANGULAR TOLERANCE 1° 1' 0" DIMENSIONS ARE NOT TO SCALE.

THIRD ANGLE PROJECTION. DO NOT SCALE.

MATERIAL SPEC. APP'D. P.F.

ORIGINALLY DRAWN BY S. FRIEND

SCALE: 1:1 (PRODUCT TITAN) SHEET 1 OF 3

TITLE: CHANGER INSTALLATION DRAWING (REJECT MECHANISM & COIN ROUTES)

SITE/GROUP: PART NO. REV [CLASS]

33001 148324001 Y4 AD

CashFlow[®] 560 changeover Applications Design Guide

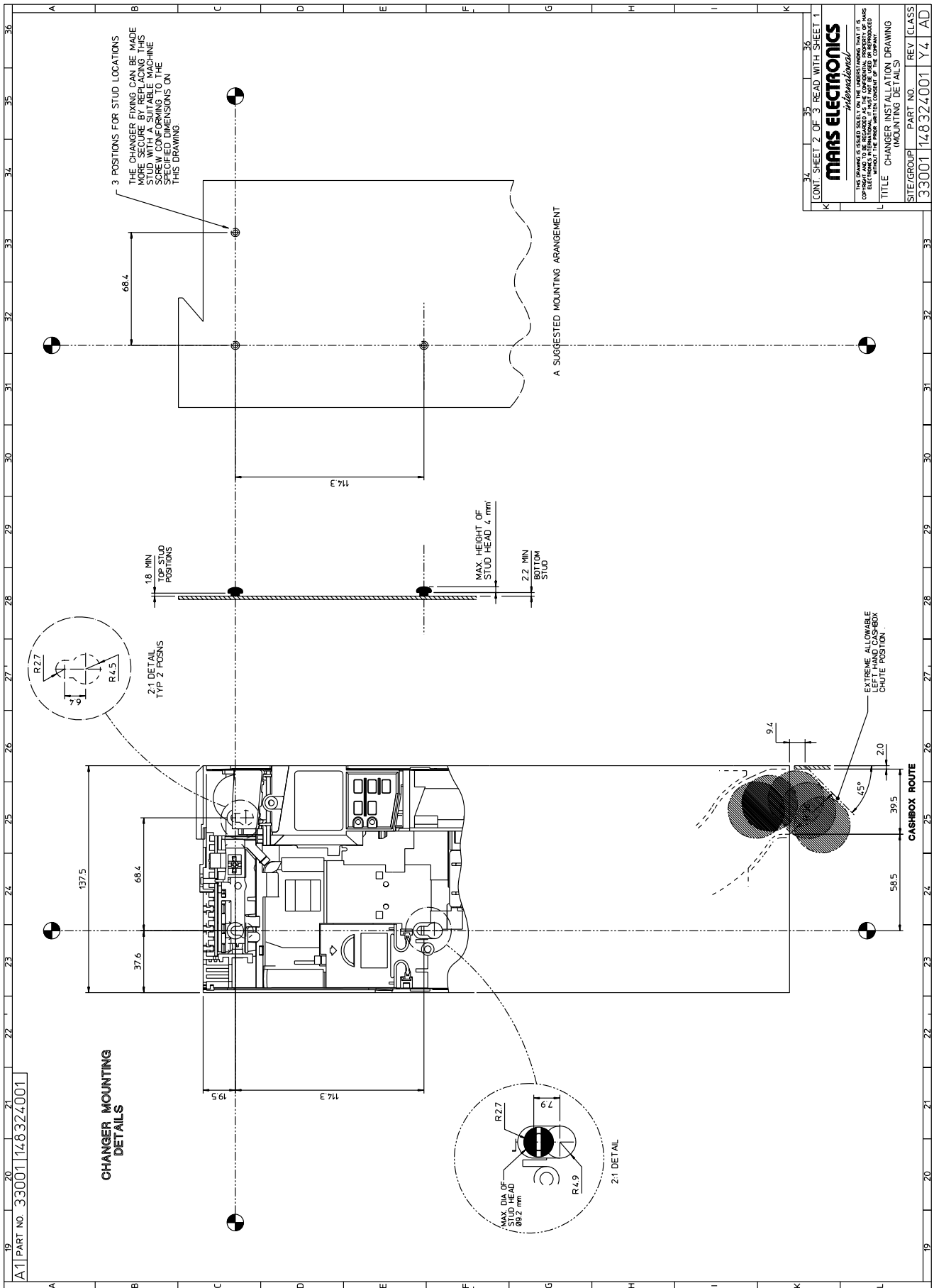

CashFlow[®] 560 changeover Applications Design Guide

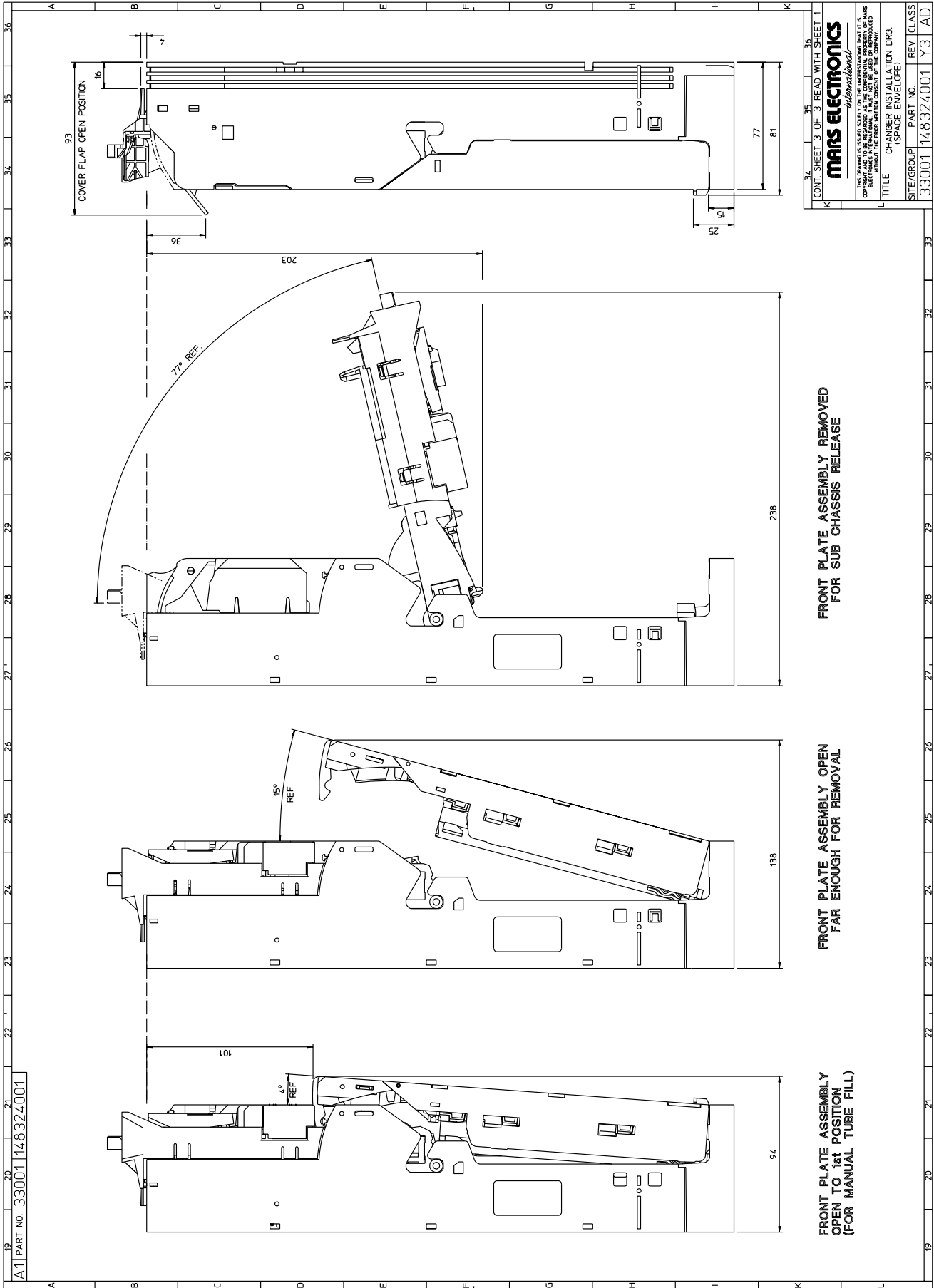

CONT. SHEET 3 OF 3 READ WITH SHEET 1	
MARS ELECTRONICS <i>Hydraulic</i>	
<small>THE DRAWER IS SOLD SEPARATE ON THE UNDERSTANDING THAT IT IS NOT TO BE USED AS A COMPONENT OF THIS PRODUCT AND TO BE INSTALLED AT THE DISCRETION OF THE USER WITHOUT THE TECHNICAL ASSISTANCE OF THE COMPANY.</small>	
TITLE	CHANGER INSTALLATION DRG. (SPACE ENVELOPE)
SITE/GROUP	PART NO. 33001 148324001
REV. CLASS	REV. CLASS Y3 AD

REPRESENTATIVE:

THE INTELLIGENT TRANSACTION™
