



# GRYPHON

## OPERATION AND SERVICE GUIDE

# GRYPHON OPERATION AND SERVICE GUIDE

---

# GRYPHON OPERATION AND SERVICE GUIDE

---

## GENERAL INFORMATION

### Overview

This Operation and Service Guide contains important information on installing, operating, and maintaining the Gryphon Coin Changer. Gryphon takes currency at high acceptance rates and provides a superior level of resistance against specific types of fraud.

### Features

- In-field configurable coin cassette
- Six auto-replenishing coin tubes
- \$1 coin payout
- LCD Display panel with instant status updates
- Patented coin inventory recognition
- MDB interface
- Ability to manage coin inventory to minimum levels

### Interface

Gryphon operates in machines that support the MDB interface. MDB is a serial communication interface standard that developed into vending equipment since 1996. It allows for multiple devices to be added to a single connection on the vending machine control board, by linking one device to another parallel to the main MDB harness.

### Specifications

The operating voltage of Gryphon coin manager is listed on the label of each product. The label is located on the left side of the device. It must not be used with any power source other than that indicated.

### Restrictions

Please consult your CPI sales representative; CPI authorized distributor, or [cranepi.com/support](http://cranepi.com/support) for a list of compatible Vending Machines.

### Safety

- The coin changer PCBs are fitted with components that can be damaged by electrostatic discharge. Please observe proper handling procedure for components exposed to the risk of electrostatic discharge.
- Do not use the coin changer if the device or connecting cables are damaged.
- Turn off power to the vending machine before you remove or clean the coin changer.
- Contact CPI if you wish to alter the construction of the device to a greater extent than that described in this manual.
- If the device is no longer required, please dispose of it correctly.

# GRYPHON OPERATION AND SERVICE GUIDE

## INSTALLATION

Please note that a single page installation guide for the Gryphon can also be found on our website.

### Unpacking the Coin Changer

Unpack the Coin Changer and immediately inspect it for damage. If the unit is damaged, return it to its original carton along with packing materials.

Notify the delivering carrier of damages and request immediate inspection. Send a letter of intent to file a claim to the delivering carrier within 72 hours from the time of delivery. Send a copy of the letter to the shipper.

Only the consignee (the person or company receiving the Coin Changer) can file a claim against the carrier for concealed damages.

Retain the original carton and packing materials for future use in shipping or transporting the Coin Changer.

### Mounting

The Gryphon was designed for ease of mounting onto existing studs provided by Original Equipment Manufacturers (OEMs). Some machines may require brackets or faceplates to mount the unit. Refer to your machine operation manual or contact your distributor/OEM for more model-specific mounting information.

1. Turn off the power to the vending machine.
2. Push and hold the yellow button on the top right of the coin manager and tilt the assembly forward to access the mounting holes. You do not have to remove the cassette.
3. Hang the Gryphon on the vending machine's mounting studs.
4. The lower mount (3) can be difficult to see through the device. Hanging the Gryphon on the top two studs first will help you locate the lower mount.

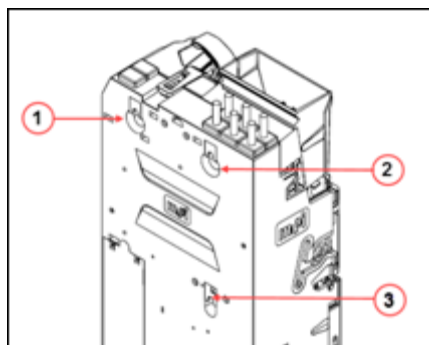



# GRYPHON OPERATION AND SERVICE GUIDE

---

5. Tighten screws if necessary, being careful not to over-tighten, and close the acceptor assembly. The lower mount is difficult to access with a large screw driver.
6. Remove the cassette. Lift it by the handle and pull towards you.
7. Fill the cassette with coins, ensuring the coins are inserted into the proper tubes.
8. Return the filled cassette to the Gryphon and insure it is properly seated.
9. Connect the MDB Cable.
  - a. If you have a bill acceptor, connect the MDB harness from the Gryphon to the bill acceptor's "Y Connector".

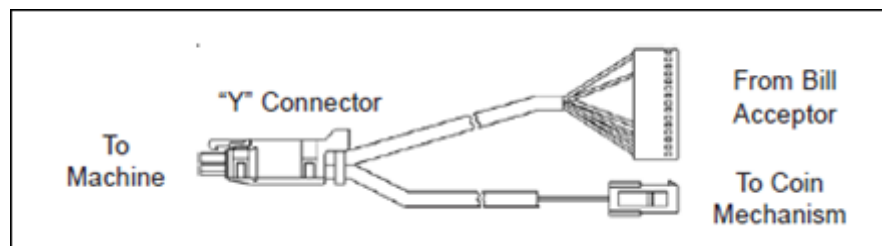

10. Tuck any excess cabling inside the vending machine, ensuring that the cables do not interfere with the Vending Machine or Gryphon's operation.
11. Restore power to the vending machine.

# GRYPHON OPERATION AND SERVICE GUIDE

## Alignment

After installation, ensure that there is a small gap (2-4mm) between the lever on the vending machine and the return lever on the coin manager.

- Depress the coin return lever on the machine door, confirm that it fully opens the acceptor lid on the coin manager and then returns smoothly, without holding the door open.

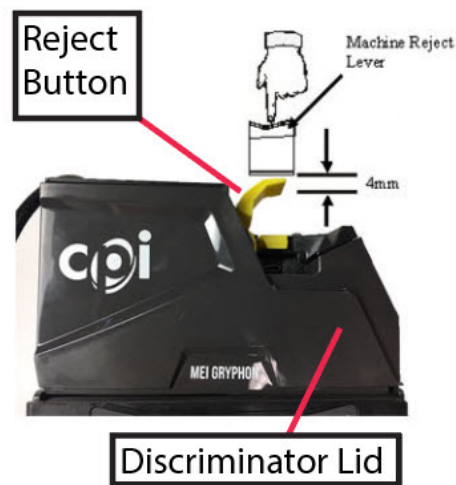

- Check the alignment of the coin input chute and the cashbox. Insert some coins to ensure that they enter the cashbox and exit into the return cup.
- Ensure that the coin chute does not rest on or open the Acceptor assembly lid.
- Align, adjust and test as necessary to ensure coins are properly routed before continuing.

## INITIAL POWER UP

The coin manager will power up and check the number of coins in each tube. If any tubes are empty, the coin manager will tell you which tubes need coins. You should fill all tubes with a minimum of three coins per tube.

Once the cassette is filled with coins, the manager will measure the tubes and display the total amount of change.

## Cassette Setup

It's easy to customize Gryphon's cassette. Use one of the many stock configurations or create your own. There are two methods to configure the cassette. Please note: the cassette must be empty before proceeding.

### Cassette Code

If you are changing the full cassette, press ≡, CASSETTE, then:

1. Enter the code located on the front of the cassette (e.g. AAB)
2. Press SAVE. If the code is not recognized, follow the Custom Cassette steps below.
3. When prompted, press start to CALIBRATE

The coin manager will now check tube capacity and display the amount of change in the tubes.

### Creating Custom Cassette

Follow these steps, if the code is not recognized or to change individual tubes. Press ≡, CASSETTE, then:

1. Select CUSTOM
2. Use the MMI to choose the tube (A – F) you'd like to edit.
3. Scroll through the coin list and select your coin.
4. Press SAVE to program the tube
5. When all tubes have been programmed, press ≡
6. When prompted, press START to calibrate

The coin manager will now check tube capacity and display the amount of change in the tubes.

# GRYPHON OPERATION AND SERVICE GUIDE

## THE MMI

Gryphon's MMI Screen has been designed with the end-user in mind. Gryphon will guide you through the initial setup and configuration using the MMI screen.

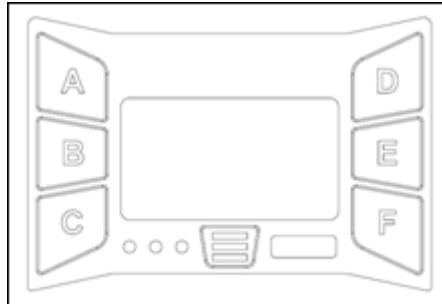

The MMI Interface updates its interface as needed in each section. Always use the on-screen guidance, but when in doubt, this chart lists general sub-menu navigation tips.







Navigation	Key
Scroll Up	D
Scroll Down	E
Move Left	A
Move Right	B
Next Page	F
Previous Page	C
Display previous menu level	Press ≡
Return to the home screen	Hold ≡ for three seconds

# GRYPHON OPERATION AND SERVICE GUIDE

---

## Service Indicators

During coin manager programming or normal operation, icons may be shown on the display. These icons will indicate if the coin manager requires any attention or will assist you in selecting a particular program mode.

Navigation	Key
	Menu Navigation
	Gryphon is OK
	Gryphon requires assistance
	Gryphon requires replacing
	Connected via USB to PC
	Connected to USB
	Error

## MMI MENUS

The resting MMI screen will display a smiling face, the word “OK” and the amount of coins currently in the cassette. If there are errors, the face will change to a frown and a message indicating the error will appear. The LED will also change accordingly to yellow or red, see page 16 for LED details.

### Audit Menu

Press the MENU KEY (≡) twice in quick succession (with the cassette in) to quickly display audit information. Each section will display for three seconds before showing the amount of change in each tube.

An audit can also be performed via the Micro-USB slot on the front of the device, under the coin reject lever with an accompanying USB drive and USB to Micro-USB dongle.

### Main Menu

Press the MENU KEY (≡) once to display the menu options. The default options on the home menu are **Par**, **Coin Set**, **Cassette** and **Setup**, though this may vary depending on the configuration you've requested. Each menu has several sub menus. The following section will detail each option and its use:

#### Par

Use this menu to initiate a par. Initiating a par will dispense coins in excess of the set par level, or request insertion of coins below par.

#### Starting float

- **Snapshot** – View or change the current par levels
  - **By value:** Set the target value. Use the D and E buttons to increment the selected decimal. Use the A and B buttons to change decimals.
  - **By levels:** View the current par levels. Press Save and Adjust to update the levels in the cassette by denomination.
- **Next** – Initiates a par
  - **Skip:** Retain the number of coins in the cassette, and adjust levels by adding coins
  - **Start:** Initiate a par. Follow the commands on screen to par.

#### Coin Set

Use this menu to select a coin set, or to enable or disable specific denominations.

- **Coins:** Enable or disable denominations
- **Coin Set ID:** View the current coin set ID
- **Coin Counts:** Displays the current number of coins in each tube. Press the A-F buttons to dispense a coin.

## Cassette

See the Cassette Setup section in the Initial Power up section on page 7.

## Setup Menu

The options in the Setup Menu enable the end user to alter and monitor the functions of the Gryphon.

## Par

Par to Level allows you to set the level of each coin, so that once the desired level is reached, additional coins will be sent to the cash box. The default Par level is completely full tubes. Changing the Par setting to Par to Value sets the default to \$50. Any coins in excess of \$50 will be deposited in the cashbox.

- **Par Mode:** Adjust the type of Par the machine uses to manage coins
  - Level – Sets the fill level for each coin. Coins above that level are sent to the cash-box.
  - Value – Sets the fill level to a total cassette value. Once the value is achieved, coins are sent to the cash-box. Gryphon dynamically alters the individual coin levels to minimize the need for manual refills.
  - Auto – Gryphon determines the optimal par level for your machine based on actual coin usage.
- **Target Value:** Sets the cassette threshold for Par to Value. Anything in excess of this number will be routed to the cash-box.
- **Target Levels:** Sets the levels for Par to Level. Coins above each set level will be sent to the cash-box.
- **Snapshot:** See the Snapshot section in the Par menu above.

## Change Management

- **Change cassette:** Enter the code listed on the front of the new cassette. If there is no code listed, click EDIT to scroll through possible configurations.
  - **Tube fill level:** Select either Fill to Max, a completely full coin tube, or Fill to Float, which will fill to the pre-selected par level.
  - **Payout mix:** Allows you to prefer large coins or small coins in the payout mix.
    - **Large coins** will return fewer coins.
    - **Small coins** is designed to keep the lowest value coins out of the cash box.

## Machine Options

- **MDB Level:** This feature has been introduced to cope with machines and changers that are older Level 2 versions to increase the backward compatibility of the changer. The default is Level 3. Only use Level 2 if the vending machine cannot operate at Level 3. This setting should not be changed under normal operation.

# GRYPHON OPERATION AND SERVICE GUIDE

---

- **Coin Counts:** Some machines coin count themselves and only use the changer counts if they differ by more than two coins. The 0 to 4 transition in TRC mode can resynchronize these machines to the same counts as the changer.
  - **TRC 0004:** Zeroes coin counts below a level of four.
  - **CF1234:** Reports the exact number of coins.
- **Float Coins:** Turn Float on or off
- **Coin Scaling:** Should be set to 5 for US and Canada. This setting should not be changed under normal operation.
- **Decimal Point 1:** This setting should not be changed under normal operation.
- **Decimal Point 2:** This setting should not be changed under normal operation.
- **Country:** Update the country by using the MDB country code specification.. It does not indicate what coin set is in the product and is typically only used for audit purposes to track which country a changer is in and should not be changed under normal operation.

## Coin Config

- **Coin setup:** Set the acceptance rate for each coin in the coin set.
- **Channel setup:** Acceptance parameters for an individual channel can be set, for example, you can change the US .10 coin from high acceptance to high security.
- **Exchange rate 2 to 1:** Set the exchange rate between two countries. The operator must set and maintain the exchange rates as they fluctuate.

## Audit Config

The selections in this section allow you to log information about the vending machine where the Gryphon is installed. This information will be captured in the audit files received from the Gryphon.

- **Machine ID:** Set Machine ID, if you'd like to change it from the serial number. This ID will appear in DEX readings.
- **Asset number:** Set the Asset number.
- **Date & time:** Set the current date and time, note that the Gryphon will reset the date and time whenever power is removed.
- **Reset Audit:** Reset all the information in this section, or reset the interims.

## General

- **Calibrate Tubes:** Ensure the cassette is empty, then press start to calibrate the tubes.
- **Currency Accepted:** Select "Only One" currency, to accept the standard currency in your country or select "All" to accept all forms of currency.
- **Clean-me level:** Gryphon displays a "Clean Me" message once the acceptance rate drops below 50%. This section allows you to customize that acceptance rate.
- **Start menu options:** Customize the menu options listed on the home screen. Select an option to disable, and then enable a new option in that spot.



# GRYPHON OPERATION AND SERVICE GUIDE

---

- **Inventory keys A - F:** The default setting allows the user to quickly dispense coins from the A - F: tubes by pressing the corresponding MMI button. This section allows you to disable that function.
- **Settings:** Save the current settings or restore the original settings.
- **Display contrast:** Adjust the contrast of the MMI display. Press Up to increase contrast and Down to decrease contrast.
- **Idle Screen amount:** Set the information displayed on the idle screen. Select between:
  - **Inventory** – Displays the full amount of money in the cassette, including the Safe Coins. Safe coins are the minimum number of coins that need to be in the tubes to continue normal operation.
  - **Payable** – Displays the total amount of money in the cassette, minus the Safe Coins
  - **Cashbox** – Displays the amount routed to the cashbox
  - **Nothing** – No information displayed

## Error Log

Select View to scroll through a list of recent errors, select reset to erase the error log.

## Test

- **Auto self-tests:** Runs an automated test of all motor functions and displays pass/fail results.
- **Manual self-tests:** Allows you to test specific functions of the Gryphon. Scroll to select the test, then click start to perform the test.
- **Gates:** Test Gryphon's routing mechanisms by selecting All Gates, or choose a specific gate to test. Opening the MMI will not interrupt the test, and will allow you to view the performance of the gate as it operates.
- **Info:** Quickly review information about the Gryphon, including current cassette information and firmware versions.

## Language

Scroll to select your preferred language.

## CHANGE MANAGEMENT

### Introduction

The Gryphon has many features that allow the product to be called a change manager rather than a change giver. In addition to the high capacity six tube cassette, these features enable the Gryphon to more effectively manage the operation of the unit and to optimize the float levels of the machine and the change payout. These features provide an opportunity for the operator to optimize vend revenue by minimizing the amount of time the unit operates in exact change mode.

### Float to Level

#### What is Float to Level?

Each tube can be filled to a specific level, after which the coins are routed to the cash box. This is the traditional float style, also known as Par. To set this up, enter the total number of coins of that type that you want to store in the changer. This level applies to all tubes holding the same type of coin. For example, if the level was 30, and the coins were stored in three tubes, there will be ten coins in each tube.

### Float to Value

#### What is Float to Value?

This feature gives the customer a simple set up and improved audit process. They use this if they want \$32.25 in the tubes but want the changer to compute and dynamically alter the ratio of coins in the tubes and give the best mix of coins ready for change.

#### How does it work?

The Gryphon continually computes coin levels for each tube based upon whether tubes are naturally replenished or depleted and how often the tube is used for change. It will dynamically adjust the mix of coins to make best use of the coins it most typically encounters, adjusting to your consumer pool.

It will always try and have at least seven coins in any tube to ensure the exact change indicator is kept off and will continue to add more coins to the tubes until the overall value for the entire cassette matches the target value set by the customer.

For example, if your customer base tends to use quarters, the Gryphon will adjust the mix of coins to compensate for quarter-heavy traffic.

#### Will it work immediately?

Yes. However, the initial mix of coins in the tubes may not be optimal.

## Auto-Float

### What is Auto-Float?

Auto-float operates with the optimal amount of money in the tubes needed to ensure the exact change light is rarely lit and that change is available for vends. Generally this reduces the float levels in day-to-day operation.

### How does it work?

It tracks incoming and outgoing coins as well as bills from peripherals to determine the optimal amount of change needed to maintain operation, averaged over a period of time, allowing for fluctuations in customer traffic.

### Will it work immediately?

Yes. However, it requires some time to gather information on how the tubes are being used. During this time, it will run the tubes at their maximum level to ensure there is always enough change.

- The consumer will not notice a difference.
- Auto-float will ask for a number of coins inserted to meet the auto float level. Any coins inserted once the float level has been achieved will be routed to the cash box – no overfill is possible.
- If a coin tube has more coins in it than is required by the auto float, the tube will dispense coins until the correct level is reached.
- The float level will change depending on the ratio of coins accepted and coins dispensed.
- Auto float only manages coins to cash box; it will stop routing to the cash box if they are needed to keep the exact change light off.
- Float Up and Float Down do not operate in auto float mode.

## Snapshot Float

### What is Snapshot Float?

When this function is chosen, it takes a "snapshot" of the current cassette and uses that data to set the float settings.

### How Does it work?

The snapshot feature allows the operator to manually fill the coin cassette tubes to a predetermined level or value and then save it as the operational float settings.

### Will it work immediately?

Yes. The snapshot feature is only available when the unit is set to 'Float to Level' or 'Float to Value'.

# GRYPHON OPERATION AND SERVICE GUIDE

## LED CODES

The three LEDs to the left of the menu key (≡) display at-a-glance diagnostics. The following chart will help you understand what the LEDs are signaling.



### Green LED Codes

Code	Meaning
<b>Solid Green</b>	Gryphon is on and working properly
<b>1 Flash</b>	Coin accepted
<b>2 Flashes</b>	Coin rejected
<b>3 Flashes</b>	Valid coin rejected, inhibited by machine
<b>Slow Flashing</b>	Gryphon is in set-up or service mode
<b>Fast Flashing</b>	USB Port in use, Audit or Firmware is processing

### Amber LED Codes

Code	Meaning
<b>Solid Amber</b>	Gryphon is inhibited by the VMC
<b>1 Flash</b>	Coin return pressed
<b>2 Flashes</b>	Acceptor error
<b>3 Flashes</b>	Cassette error
<b>4 Flashes</b>	Dispenser error

### Red LED Codes

Code	Meaning
<b>Red, Green and Amber cycle five times</b>	Boot up sequence, wait to interact with the Gryphon until the cycle completes and the green light is steady.
<b>Alternating red and green</b>	Gryphon is not functioning properly. Remove and return to a service center.

# GRYPHON OPERATION AND SERVICE GUIDE

## CPI SYNQ

The Gryphon was designed in tandem with the CPI Synq. The CPI Synq is a connected platform that enables simplified full-system diagnostics and remote management of CPI payment devices on any machine, all in the palm of your hand.

CPI Synq redefines your cash experience:

- Simple, visual diagnostics
- Video instruction and guided troubleshooting
- Configuration controls
- Optimal cash float in the machine
- Remote system monitoring
- Improved up-time in the field
- Lower total cost of ownership across all CPI Synq connected devices

## Features

Feature	Description
<b>MDB Sniffing</b>	Get at-machine or remote diagnostics, enabling fast and accurate troubleshooting which reduces cost of ownership.
<b>PayRange mobile payment compatible</b>	Increase sales by enabling remote payment options.
<b>Performance analytics</b>	Monitor your route with the Simplifi DMS
<b>Over-the-Air software and currency updates</b>	Remote software changes lower cost of ownership by cutting down on time spent at the machine
<b>Asset Management</b>	Change device configurations easily via the app

## Installation

### Create an Account

Visit [cranesimplifi.com/register/Synq](https://cranesimplifi.com/register/Synq) to create an account. This only needs to be done at the operator level, and only needs to be done one time.

### Download the Simplifi app

Search the iPhone App Store for “Simplifi” and download it to your mobile device.

### Assign the Synq

Each Synq must be registered via the Simplifi app, which requires internet access to complete the registration process.

1. Connect the Synq via MDB to a power source and open the Simplifi App (See Installation for Synq power connection details).
2. On the POS list, locate the device labeled “Unknown POS”
3. Press the + icon next to “Unknown POS” and name the Synq to help identify it later. For example, “Second Floor Snack Machine”.
4. Once you’ve named the Synq, the registration process is complete. It is ready to be installed into a vendor. See Installation for details.

The Synq will now appear in your list of devices when you are within Synq’s 100ft broadcast range.

If you ever need to unregister a device, press and hold the button on the side of the Synq to activate Discovery Mode. Discovery Mode allows you to re-assign the Synq. If you do not re-assign, the Synq reverts to current state.

# GRYPHON OPERATION AND SERVICE GUIDE

## Connect the Synq to Gryphon

CPI Synq can be installed in series, anywhere on the MDB line that makes it easy for you to operate. Both ends of the MDB must be connected to power up and Synq must be connected to the Synq port on the Gryphon in order to communicate with the devices.

If there is a Synq cable pre-installed on your Gryphon, simply connect the Synq to the pre-installed cable. If there is not a Synq cable pre-installed, you will need to remove the PCB Cover behind the acceptor module.

1. Lift up on the yellow tab and pull the Acceptor Module forward

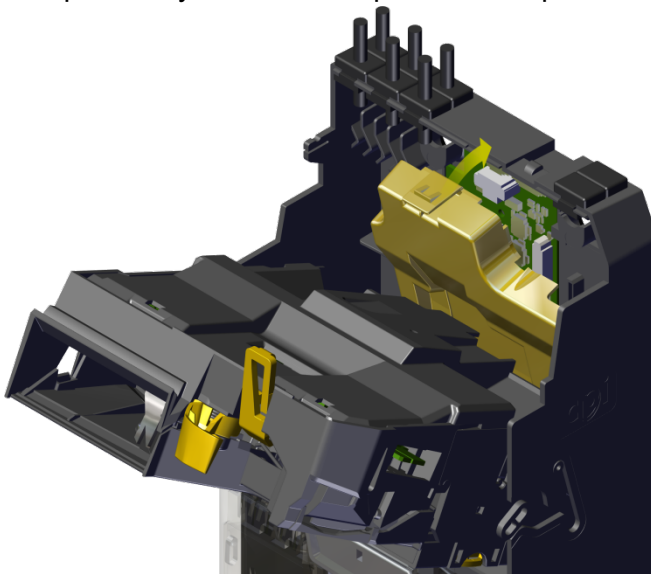

2. Press down on this tab to remove the PCB Cover

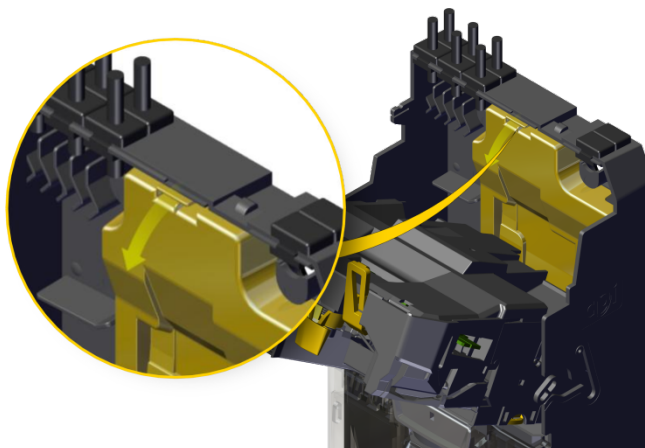

3. Connect the Synq cable to this port.

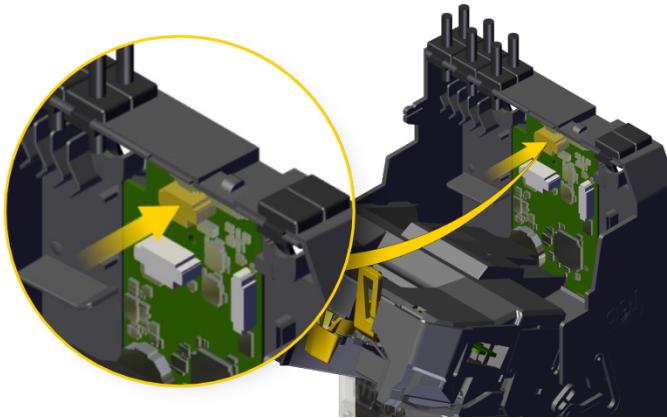

4. Reconnect the PCB cover and close the acceptor module

## Simplifi App

The Simplifi app works in conjunction with CPI Synq. It features troubleshooting and video tutorials for common vending errors, in addition to providing easy-to-use configuration and diagnostic tools.

## Troubleshooting with the Simplifi App

When in range of Synq enabled vendors, our beacon technology allows you to quickly review the health of your machines. The clean design and at-a-glance icons greatly reduce the time spent on service calls.

Each vendor is listed with its serial number and an icon indicating its general health. Green is healthy, yellow is needs attention and red is out of service.

POS	Pos Description	BLE Device S/N	Health Status
POS	Pos Description1	1234564566	Red (Out of Service)
POS	Pos Description2	1234564566	Yellow (Needs Attention)
POS	Pos Description4	1234564566	Yellow (Needs Attention)
POS	Pos Description3	1234564566	Green (Healthy)

Tapping any vendor on the list gives access to all alarms from all its peripherals, allowing the technician to quickly identify problems. Each alarm is listed in priority order, with simple one-line descriptions of each alarm:



# GRYPHON OPERATION AND SERVICE GUIDE

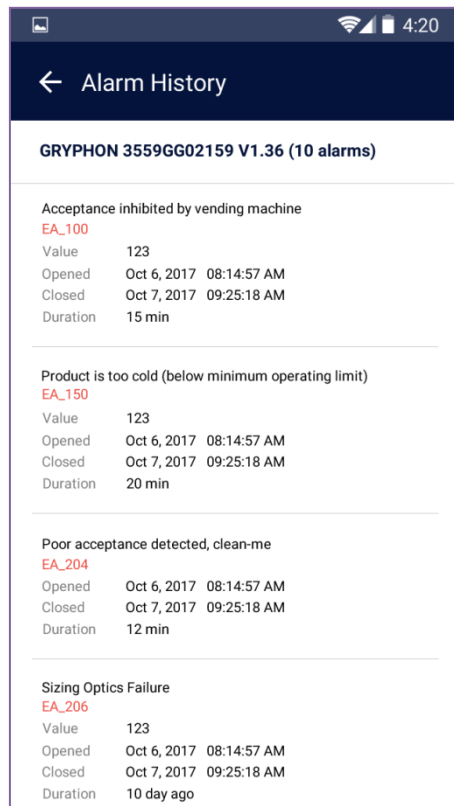

Tapping any error gives the user access to a troubleshooting guide. One more tap provides more detailed troubleshooting steps and/or instructional videos to increase the rate of single-visit service calls.

# GRYPHON OPERATION AND SERVICE GUIDE

## Configuring Gryphon with the Simplifi App

You can make basic configuration changes to the Gryphon when using the Simplifi app. Connect to the Gryphon you'd like to configure and then select your preferences, then tap Update to save your changes.

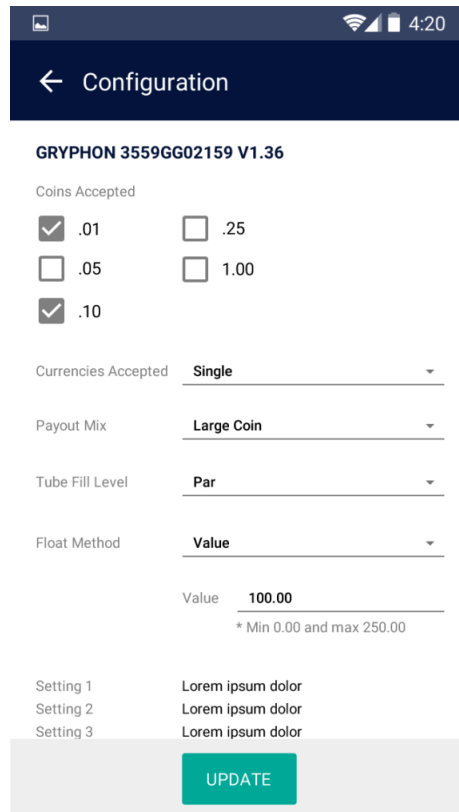

## Synq Error Codes

The Status LED on the side of the Synq provides at-a-glance information about the Synq's health.

Color	Sequence	Meaning
Green	Steady On	Synq is working properly
Red and Green	Alternating	Boot up sequence
Green	Fast Flashing	Active connection to Simplifi App
Green	Slow Flashing	Updating Firmware/Configuration
Amber	Steady On	Synq is not assigned
Amber	Fast Flashing	Discovery Mode
Red	Unit failure, replace	Unit failure, replace

## CLEANING THE GRYPHON

Before cleaning, take the proper steps to avoid causing damage during cleaning:

- Turn off the power
- Use a damp cloth only, there should be no way for fluid to enter the device
- Do not use any solvents or scouring agents, these will damage the device

### Cleaning the Coin Path

Passing coins can leave residues while travelling through the validator. These residues should be cleaned from time to time for optimal operation, roughly once a year or when indicated by the MMI.

#### Cleaning Aids

- Compressed air
- Small brush
- Damp cloth
- Lukewarm water

#### Steps

1. Turn power off.
2. Open acceptor assembly at the coin entry and hold it open.
3. Remove any debris from the validation and sorting area. Dust off any accumulation with a small brush or compressed air.
4. Clean the coin path with a damp cloth.
5. Close the acceptor assembly.

### Cleaning the Sorting Control

1. Follow the steps above, then unlatch the acceptor assembly and remove it from the changer.
2. Detach rear coin validator cover.
3. Slightly pull apart the bottom frame of the validator on both sides, separating the lower snap in hooks from the bottom to the top.
4. Check cover prism for dirt, clean prism from the inside using a soft, dry cloth or cotton ball.
5. Check both sides of the sorting control for dirt.
6. Clean diodes using a soft, dry cloth or cotton ball.
7. Reinstall the validator cover.
8. Reinsert acceptor assembly in coin changer until it is seated properly.
9. Turn power on.

### Cleaning Payout Sensor System

If you continue to receive cleaning notifications, or the changer has difficulty paying out, the payout sensor system is likely soiled and requires cleaning.

# GRYPHON OPERATION AND SERVICE GUIDE

---

1. Turn power off.
2. Remove the coin changer from the vending machine.
3. Remove the cassette.
4. Grab under the middle pay-out disc and press the disc out from the payout set from the bottom.
5. Press out the left and right discs in the same fashion.
6. Clean the discs with a dry cloth.
7. Clean the sensors with a dry brush or dry toothbrush.
8. Reinstall payout discs, being careful to return them to their original alignments.
9. Reinsert coin cassette.
10. Reinstall the coin changer into the vending machine.
11. Restore power.

## Cleaning Filling Level Sensor System

If the Gryphon reports incorrect tube levels, check the filling level sensors and run an auto self-test. This is best done with an empty coin cassette.

## Cleaning the Coin Cassette

If the light transmitter and light collectors are dusty, you should clean all the reflecting surfaces. Do not use water, any solvents, scouring agents and paper towels or kitchen paper which attack the sensitive surfaces of the optical parts or leave residues.

### Cleaning Aids

- Isopropyl alcohol
- Cotton swabs
- Microfiber cloth

### Steps

1. Remove the coin cassette from the coin changer.
2. Use a cotton swab with isopropyl alcohol to clean all 45° surfaces.
3. Thoroughly dry all surfaces as residue-free as possible using a microfiber cloth.
4. Reinsert coin cassette.
5. Run an auto self-test to check the values of the filling level sensors again.
6. If the values are still low after cleaning, clean disassembled cassette or contact your service technician.

# GRYPHON OPERATION AND SERVICE GUIDE

## TROUBLESHOOTING

### Status Lights

The three status lights to the left of the MENU KEY (≡) are used to quickly identify the Gryphon's status.

Color	Message
Green	The unit is functioning properly.
Yellow	The unit requires adjustment, see the MMI for details.
Red	The unit requires maintenance and should be returned to a service center.

### Problems and Possible Causes

The Gryphon MMI will guide you through troubleshooting steps. If you are still unable to locate the error, review this list for possible causes and solutions.

Problem	Possible Causes	Remedy
No communication with VMC	MDB/JVI coin changer has not received any machine commands for 10 seconds	<ul style="list-style-type: none"> <li>• Connect cable to the vending machine correctly</li> <li>• Power vending machine</li> </ul>
No response from VMC	BDV/Executive vending machine does not respond to coin changer commands	<ul style="list-style-type: none"> <li>• Connect cable to the vending machine correctly</li> <li>• Power vending machine</li> </ul>
No response from external audit unit	External audit unit does not respond to coin changer commands as not connected correctly not available	<ul style="list-style-type: none"> <li>• Check proper connection</li> <li>• Deactivate communication with audit unit</li> </ul>
Coin jam in Acceptor assembly	Sensor error in coin validator <ul style="list-style-type: none"> <li>• Sensor covered</li> <li>• Sensor defective</li> </ul>	<ul style="list-style-type: none"> <li>• Remove coin jam</li> <li>• Clean coin path</li> <li>• Display coin validator diagnostic screen, if necessary, contact service technician</li> </ul>
Coin jam in the sorting module	Sensor error in coin validator <ul style="list-style-type: none"> <li>• Sensor covered</li> <li>• Sensor defective</li> </ul>	<ul style="list-style-type: none"> <li>• Remove coin jam</li> <li>• Clean coin path</li> <li>• Display coin validator diagnostic screen, if necessary, contact service technician</li> </ul>
Error in sizing optics	Sensor error in coin validator <ul style="list-style-type: none"> <li>• Sensor covered</li> <li>• Sensor defective</li> </ul>	<ul style="list-style-type: none"> <li>• Remove coin jam</li> <li>• Clean coin path</li> <li>• Display coin validator diagnostic screen, if necessary, contact service technician</li> </ul>

# GRYPHON OPERATION AND SERVICE GUIDE

Problem	Possible Causes	Remedy
Checksum of validator defective	Error in coin validator's memory	Check and correct coin validator configuration
No response from validator module	<ul style="list-style-type: none"> <li>• Communication with coin validator interrupted</li> <li>• Coin validator defective</li> </ul>	<ul style="list-style-type: none"> <li>• Remove rear cover from coin changer, unfold coin validator and check whether ribbon cable is still connected correctly with interface module (bottom PCB) and coin validator</li> <li>• Replace coin validator</li> </ul>
Tube sensors Defective	<ul style="list-style-type: none"> <li>• Filling level sensors soiled</li> <li>• Filling level sensors defective</li> </ul>	<ul style="list-style-type: none"> <li>• Remove coin jam</li> <li>• Clean coin path</li> <li>• Display coin validator diagnostic screen, if necessary, contact service technician</li> </ul>
Checksum of changer Defective	<ul style="list-style-type: none"> <li>• Error in coin changer's data memory</li> </ul>	Check and correct coin changer configuration in the settings menu
No response from cash- less system	<ul style="list-style-type: none"> <li>• Card system does not respond to coin changer commands as not connected correctly or defective no longer available</li> </ul>	<ul style="list-style-type: none"> <li>• Check card system</li> <li>• Deactivate communication with card system</li> </ul>
No response from bill validator	Bill validator does not respond to coin changer commands as: <ul style="list-style-type: none"> <li>• Not connected correctly or defective</li> <li>• No longer available</li> </ul>	<ul style="list-style-type: none"> <li>• Check bill validator</li> <li>• Deactivate communication with bill validator</li> </ul>
No communication with hopper	Hopper does not respond to coin changer commands as <ul style="list-style-type: none"> <li>• Not connected correctly or defective</li> <li>• No longer available</li> </ul>	<ul style="list-style-type: none"> <li>• Check hopper</li> <li>• Deactivate communication with hopper</li> </ul>
No communication with recycler	Recycler does not respond to coin changer commands as <ul style="list-style-type: none"> <li>• Not connected correctly or defective</li> <li>• No longer available</li> </ul>	<ul style="list-style-type: none"> <li>• Check recycler</li> <li>• Deactivate communication with recycler</li> </ul>
Payout jam in tube	Payout disc could not be driven from initial position as: <ul style="list-style-type: none"> <li>• Coin jam in payout area</li> </ul>	<ul style="list-style-type: none"> <li>• Remove coin cassette and then jammed coin. Reinsert cassette and pay out coin from relevant</li> </ul>

# GRYPHON OPERATION AND SERVICE GUIDE

Problem	Possible Causes	Remedy
	<ul style="list-style-type: none"><li>• Payout disc jam</li><li>• Payout motor defective</li></ul>	<p>tube using inventory key. The error will be reset</p> <ul style="list-style-type: none"><li>• Remove coin cassette, dismount and reinsert disc. If the coin cassette has been removed, the Gryphon tries after 10s to turn the disc in final position again and resets the error</li><li>• Contact service technician or replace payout set</li></ul>
Check position of tube cassette	<ul style="list-style-type: none"><li>• Coin cassette not inserted and engaged correctly</li><li>• New coin cassette not suited for old housing</li></ul>	<ul style="list-style-type: none"><li>• Insert coin cassette correctly and let engage</li><li>• Replace housing</li></ul>

## REMOVING A TUBE

### Unlock the tubes

The six coin tubes are locked into the cassette in groups of two by three latches. There's a latch on each side of the cassette:

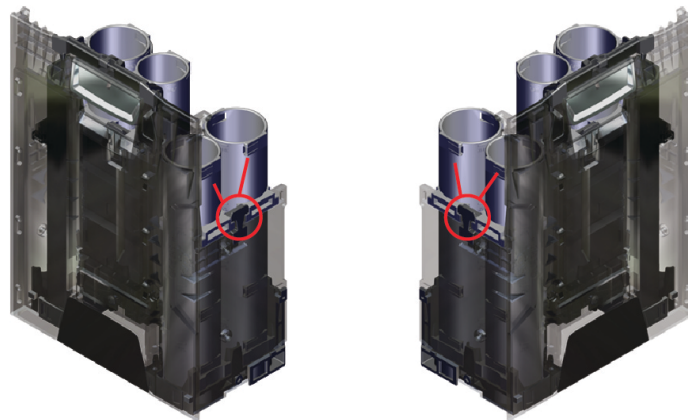

The third latch is behind the fascia on the front of the cassette. To unlatch, first remove the fascia by gripping from the lower right of the label panel, then pulling towards you and to the left, as you might turn a page:

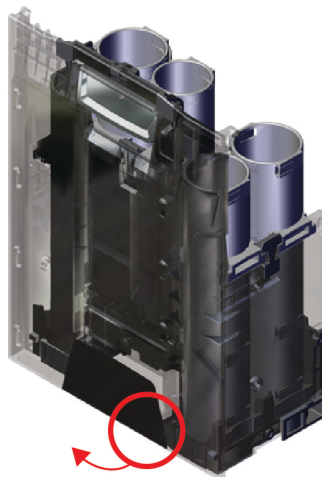



# GRYPHON OPERATION AND SERVICE GUIDE

---

Once the fascia is removed, unlatch the tube lock and remove the tubes:

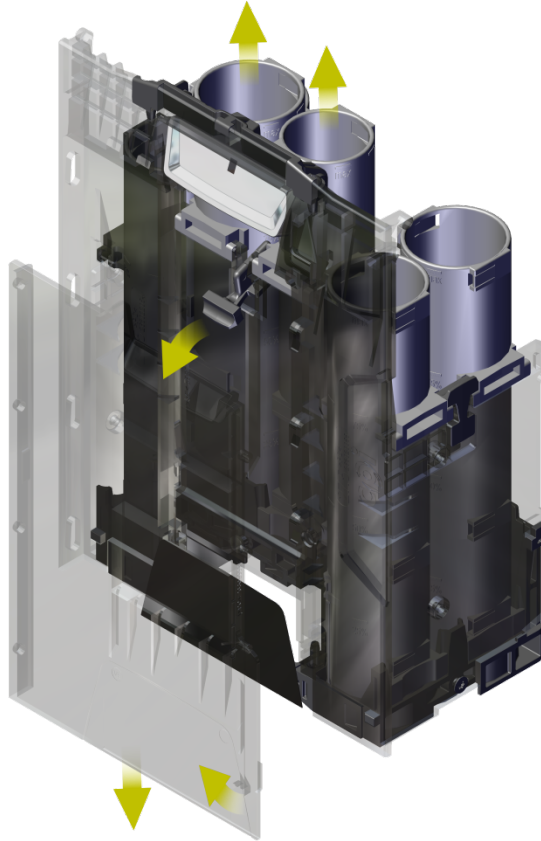

## EXPLODED VIEWS

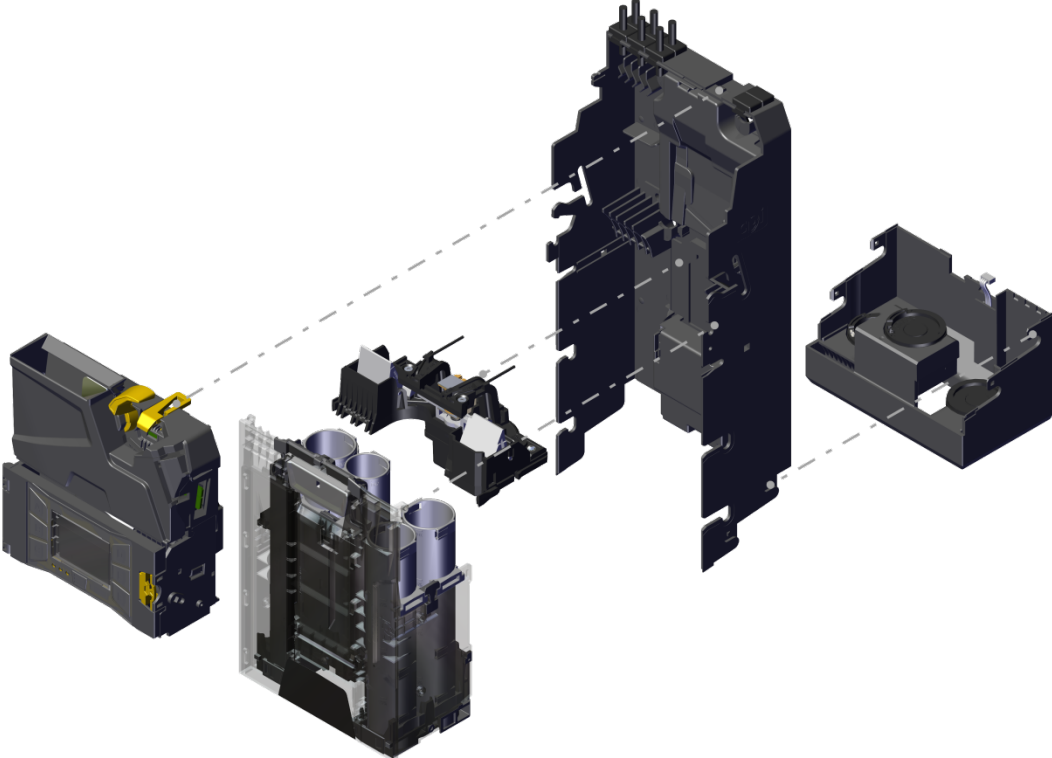

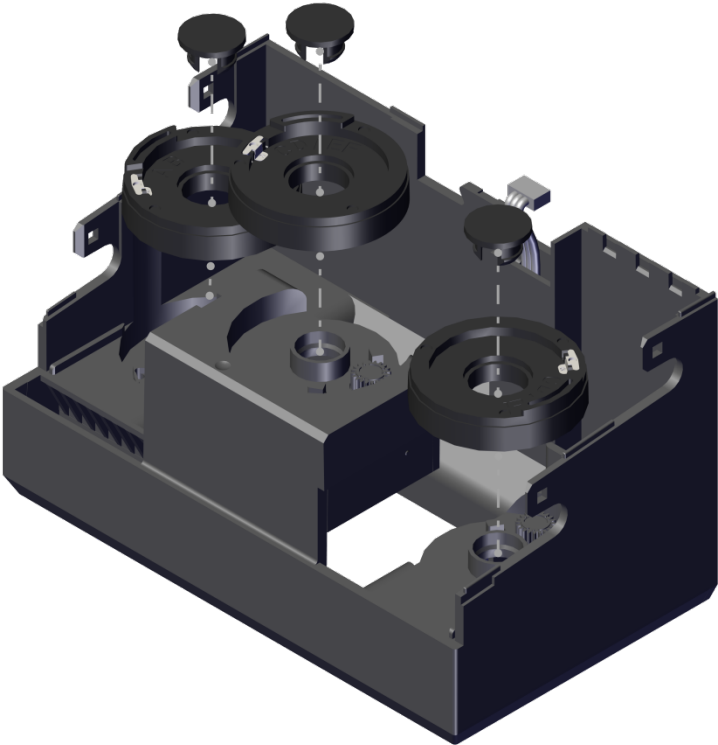
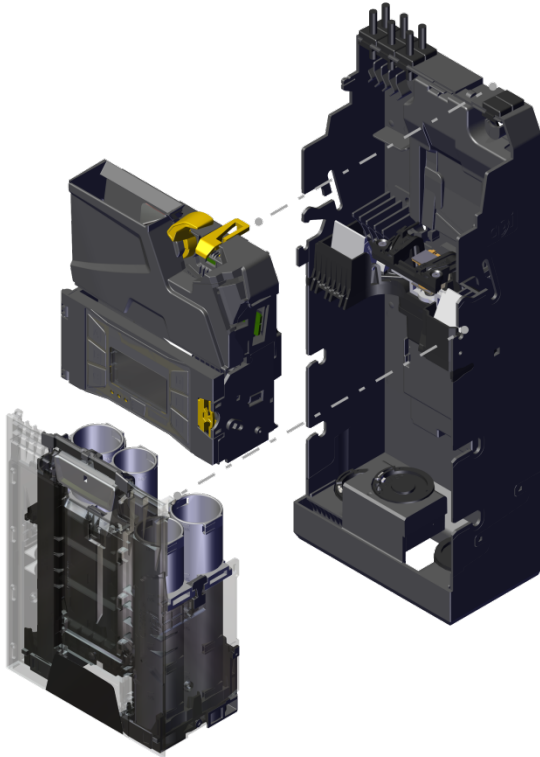

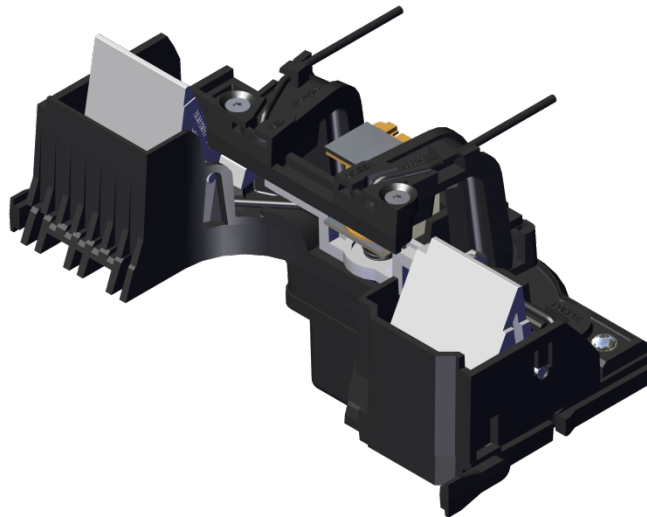
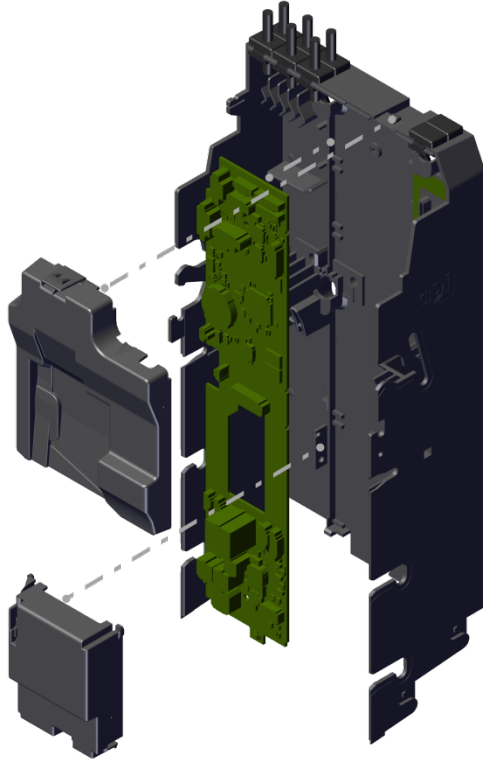

# GRYPHON OPERATION AND SERVICE GUIDE

---

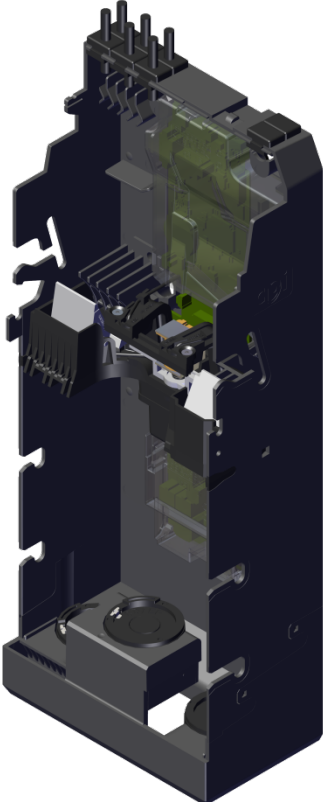
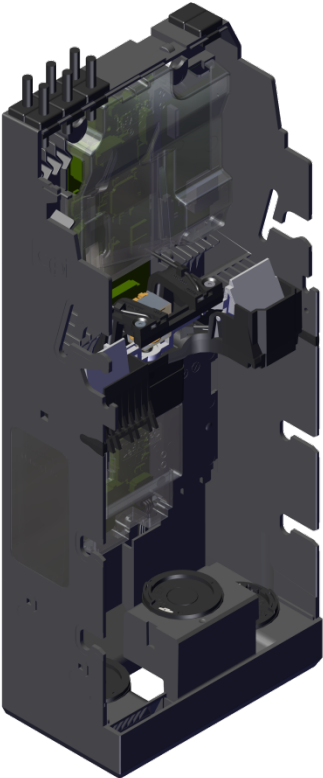

# GRYPHON OPERATION AND SERVICE GUIDE

---

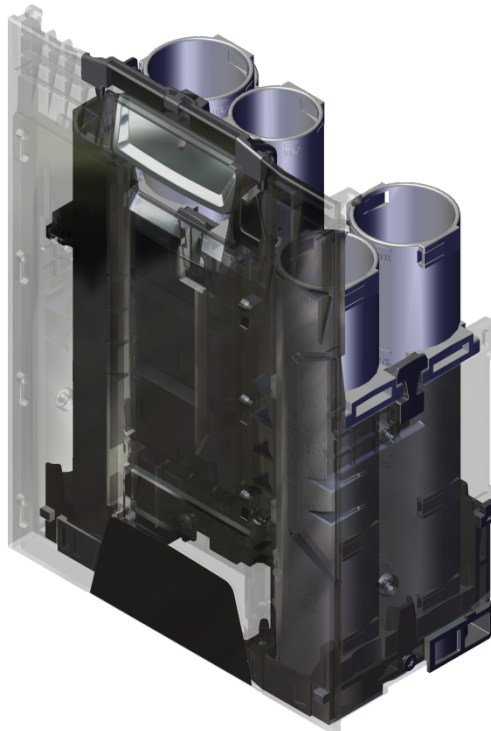

# GRYPHON OPERATION AND SERVICE GUIDE

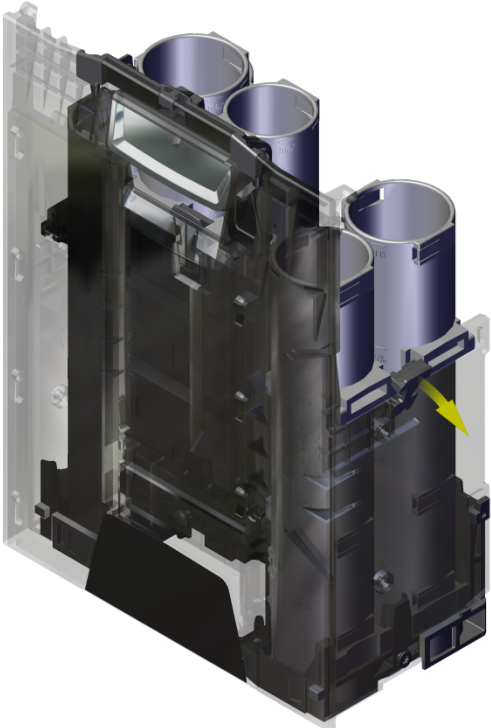
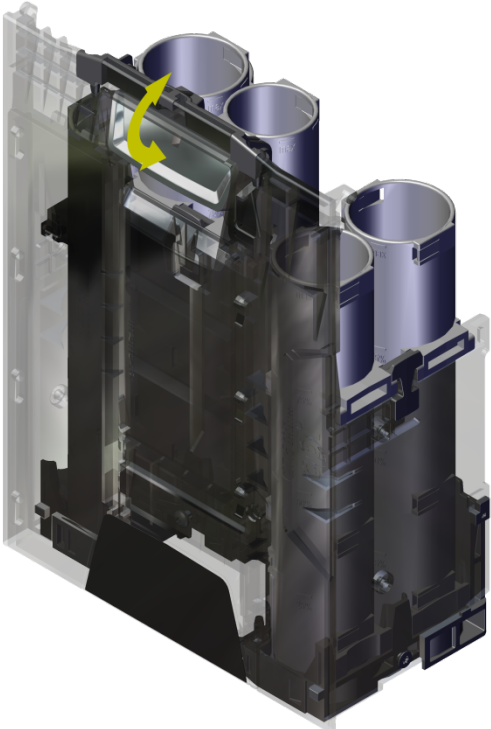

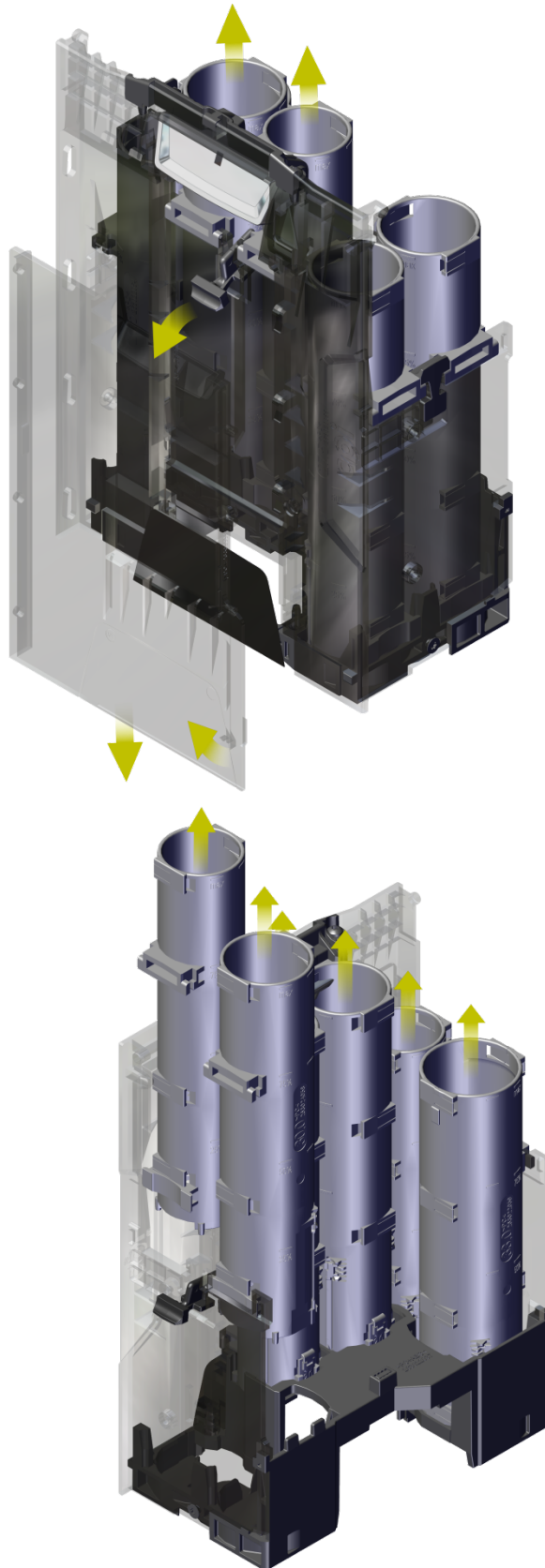



# GRYPHON OPERATION AND SERVICE GUIDE

---

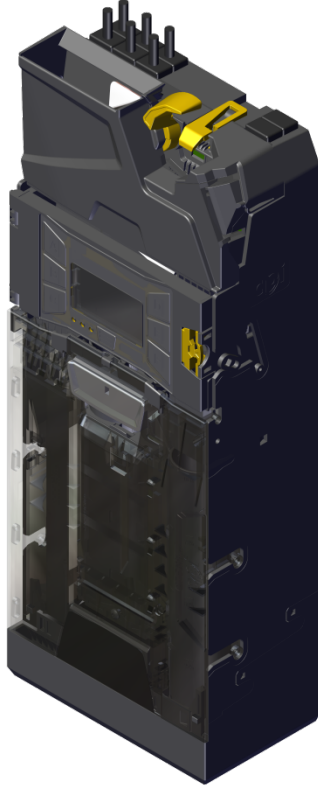

# GRYPHON OPERATION AND SERVICE GUIDE

---

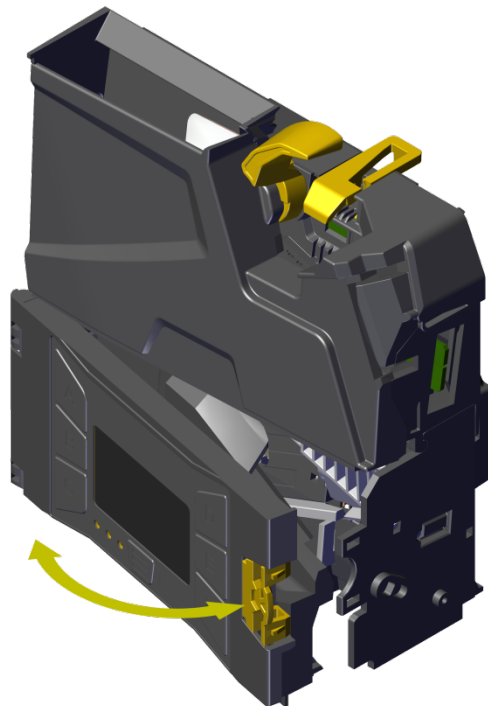
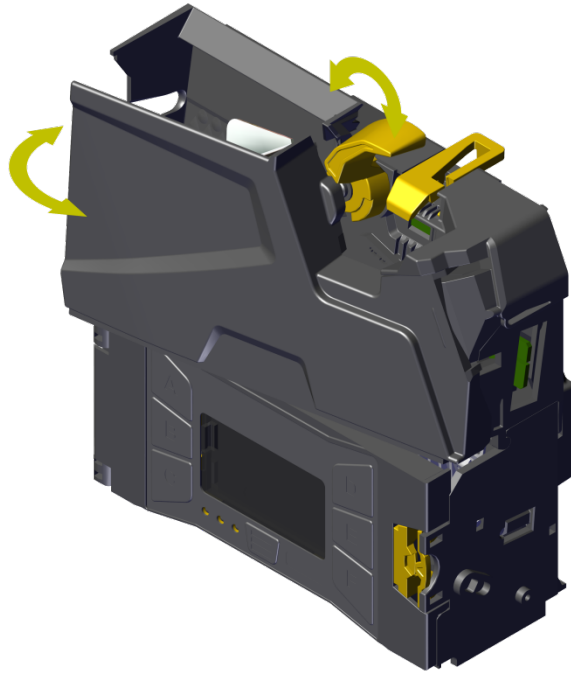

# GRYPHON OPERATION AND SERVICE GUIDE

---

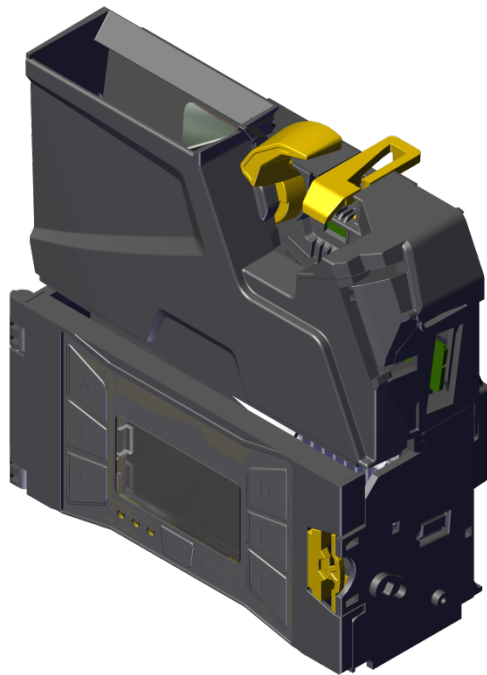
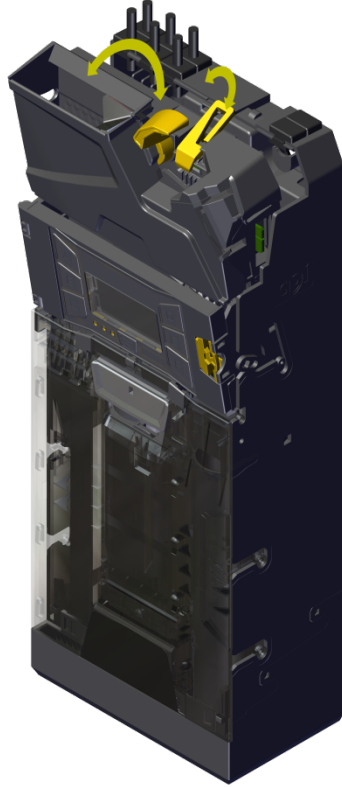

# GRYPHON OPERATION AND SERVICE GUIDE

---

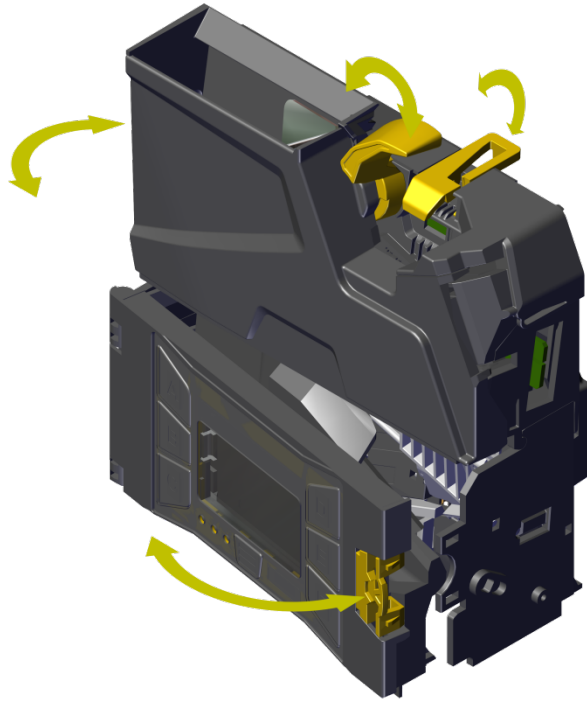

# GRYPHON OPERATION AND SERVICE GUIDE

## DIMENSIONAL DRAWINGS

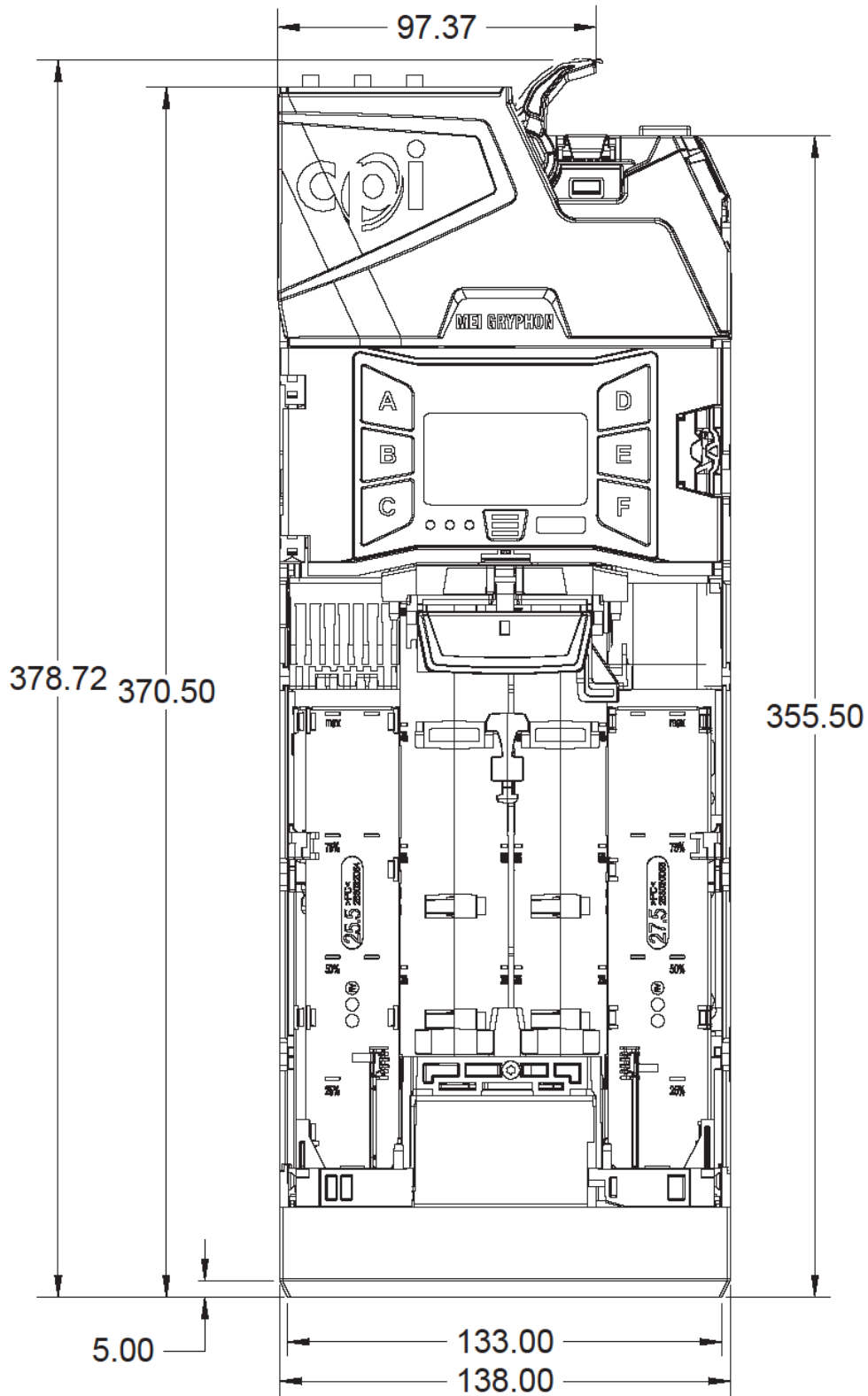

# GRYPHON OPERATION AND SERVICE GUIDE

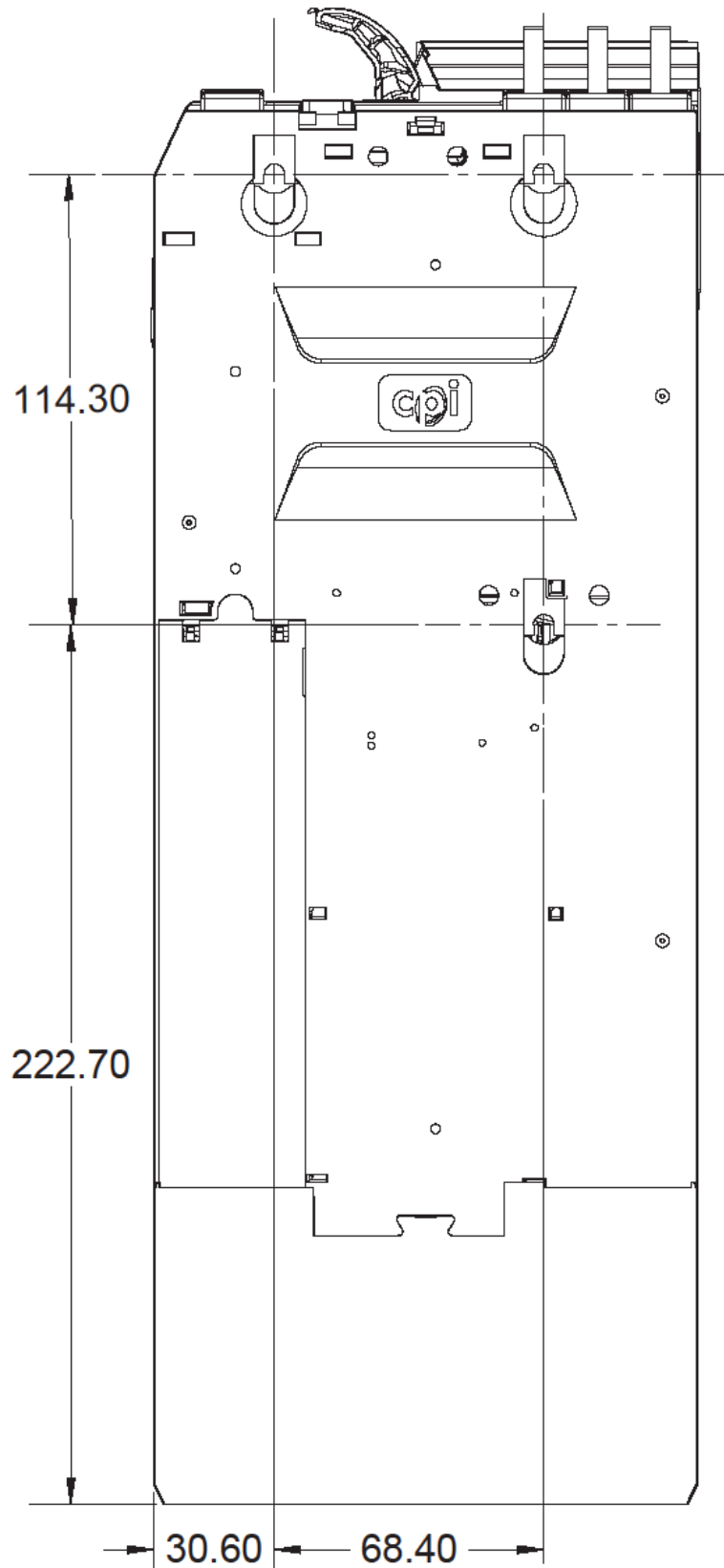

# GRYPHON OPERATION AND SERVICE GUIDE

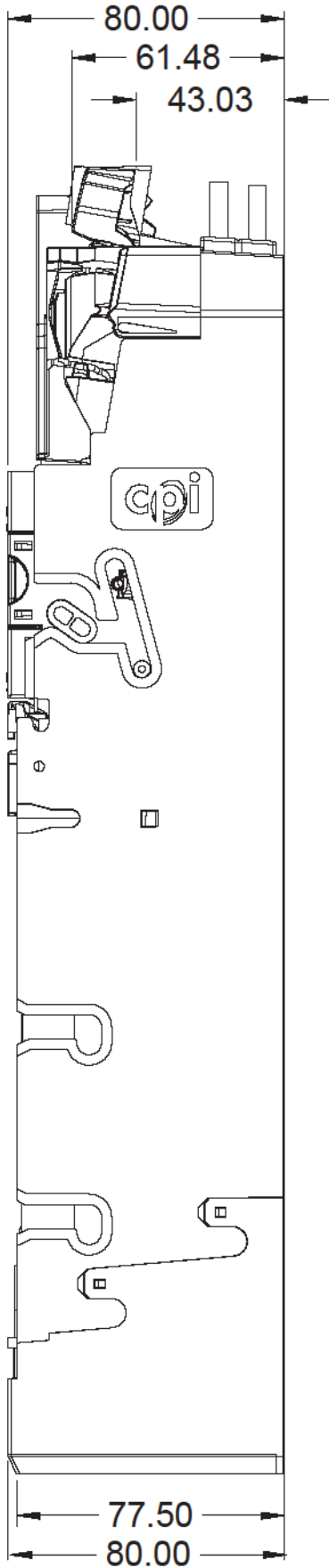

# GRYPHON OPERATION AND SERVICE GUIDE

---

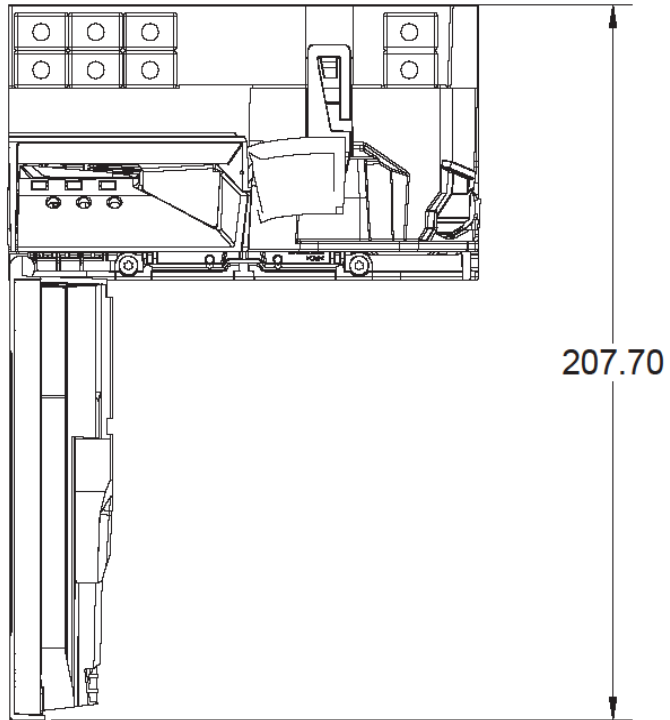



# GRYPHON OPERATION AND SERVICE GUIDE

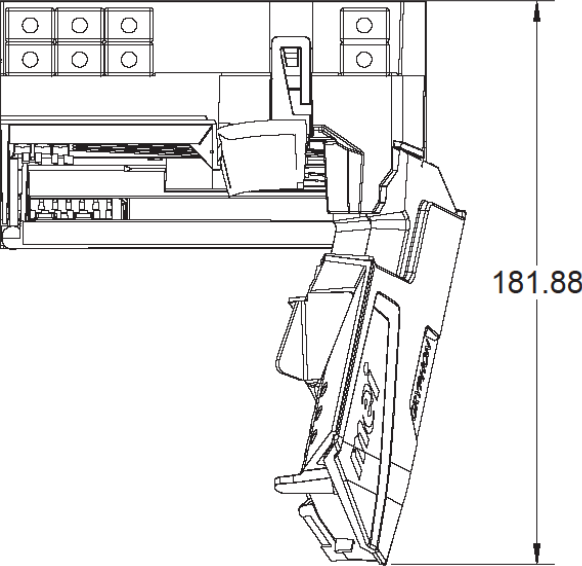

# GRYPHON OPERATION AND SERVICE GUIDE

---

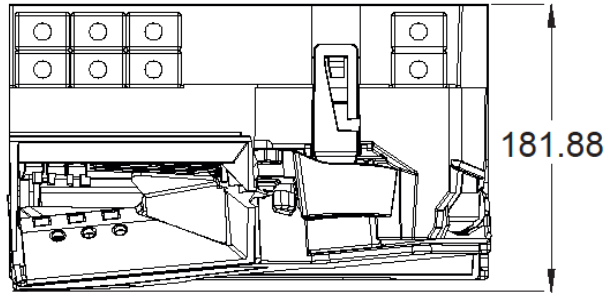

# GRYPHON OPERATION AND SERVICE GUIDE

---

## FINE PRINT

### Owner's Responsibility

Upon request, owner must show proof of purchase when submitting equipment for service during the warranty period. Owner will assume all freight charges for shipment of equipment to an authorized service center while under warranty, and to and from the service center when outside the warranty period. Owner is responsible for out-of-warranty repair expenses, chargeable at prevailing rates set by authorized service centers. Complete written information must be supplied to the authorized service center for all items returned, including serial and model number, and a description of the malfunction.

### Serial Numbers

The first three digits of the serial number contain the manufacturing date code. This code indicates the beginning of the warranty period. The first two digits indicate the week of manufacture; the third digit indicates the year of manufacture. For example: a Coin Changer with a serial number of 30720033333 was manufactured in the 30th week of 2017 (July 2017).

### CPI, Inc. Responsibility

During the warranty period, MEI, Inc. will repair or replace any parts which fail to function properly because of defects in material or workmanship. MEI, Inc. shall not be liable for any consequential damages as a result of defects in material or workmanship.

Damage due to electrical overload, negligence, accidents, misuse, abuse, vandalism, or an act of God is not covered by MEI, Inc. warranty. Any alteration of the product after manufacture voids the warranty in its entirety.

The product to be repaired under warranty must be delivered to an authorized service center. Repairs or installation at the owner's location are not included in the warranty. During the warranty period, MEI, Inc. will assume freight charges for return of the owner's equipment from the closest authorized service center via UPS or common carrier.

### Service

For service information, contact MEI, Inc. or any MEI authorized service center. Parts and labor that are MEI, Inc. responsibility will be provided without charge. Other service is at owner's expense. For service information, or the name of the authorized service center nearest you, Call or e-mail:

**CPI Customer Service:**

1-800-345-8215

**CPI Technical Support**

1-800-345-8172 or [cranepi.com/support](http://cranepi.com/support)