



XBA

Bill Acceptor

Installation Guide
&
Service Manual



International Currency Technologies

Use of Materials Limitations

International Currency Technologies Corporation (ICT) all rights reserved.

All materials contained are the copyrighted property of ICT.

All trademarks, service marks, and trade names are proprietary to ICT.

ICT reserves the right at all times to disclose or to modify any information as ICT deems necessary to satisfy any applicable law, regulation, legal process or governmental request, or to edit, refuse to post or to remove any information or materials, in whole or in part, in ICT's sole discretion.

Contents

1. General Information	
1-1. Specifications.....	3
1-2. Dimensions.....	4
1-3. Harness Application.....	5
1-4. Bezel Styles.....	10
2. Software download and test	
2-1. Download Firmware.....	11
2-2. Auto Testing Tool.....	15
2-3. Component Names.....	28
2-4. Assembling Procedure.....	29
3. Operation	
3-1. Operation Flowchart.....	36
3-2. I/O Circuit.....	37
4. Maintenance.....	40
5. Troubleshooting	
5-1. Introduction.....	41
5-2. Failed to Power Up.....	42
5-3. Failed to Communicate.....	43
5-4. Low Acceptance.....	44
5-5. Wrong Credit Output.....	45
5-6. Motor with Strange Sound.....	46
5-7. No Diagnostic LED Status.....	47
5-8. Bill Acceptor Error Code.....	48
6. Parts and Assembly Views	
6-1. Exploded Views.....	58
6-2. Circuit Board Overviews.....	64
7. Model Number Configuration.....	65

1. General Information

1-1. Specifications

General

Acceptance Rate	98% or greater
<i>*Note: The acceptance rate excludes notes that are dirty, wet, broken or wrinkled.</i>	
Bill Insertion	Four way acceptable
Transaction Speed	Approx. 2.5 s to stack
Interface	Pulse, MDB, RS232
Installation	Indoor & Outdoor

Electrical

Power Source	12V DC±10% 24V DC±10% 34V DC±10%
Power Consumption	Normal Mode- Standby : 0.15A, 1.8W Operation: 1.0A, 12W Maximum: 2A, 24W Power Saving Mode- Mode 1: 50µA Mode 2: 15µA
Operation Environment	Operation Temperature: -20°C~65°C Storage Temperature : -30°C~70°C Humidity: 30%~95%RH (no condensation)

Mechanical

Bill Box Capacity	Approx. 200 bills 400 bills
Weight	Approx. 1.5kg
Outline Dimension	Refer to page 4
Bill Accepted Width	62~77mm

1-2. Dimensions

◆ Two Sided Bezel

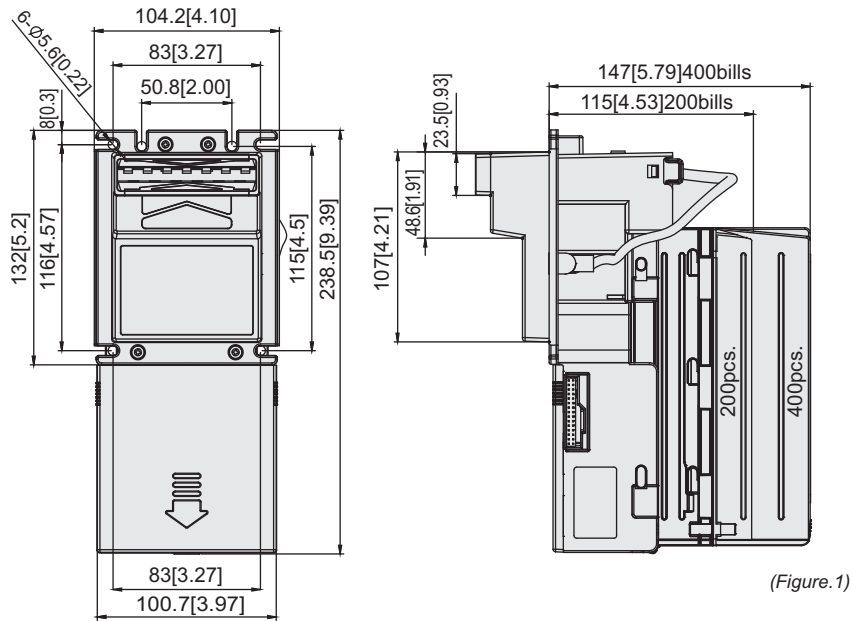

◆ TOB Bezel

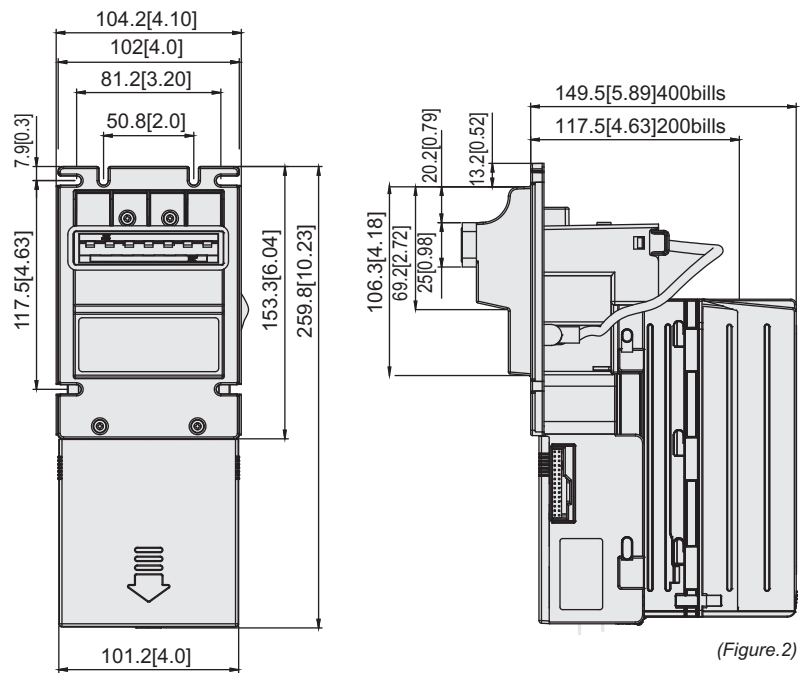

Unit : mm [inch]

1-3. Harness Application

Interface	Used Voltage	Mode	Usage	Harness	Page
MDB	12VDC	Sleep	Power & Data comm.	WEL-RV705	6
	12/24VDC			WEL-RS7P02	6
	34VDC	Normal		WEL-RM006	7
Pulse	12VDC	Sleep	Power & Data comm.	WEL-RV701	7
			Extension Wire	CU-R961	8
	24VAC	Normal	Power & Data Comm.	WEL-RV703	8
			Extension Wire	WEL-RV702	9
ICT Protocol	12VDC	Normal	Power & Data Comm.	WEL-RXBA18	9
			Extension Wire	CU-R961	8

*Data Comm. : Data Communication.

(Table.1)

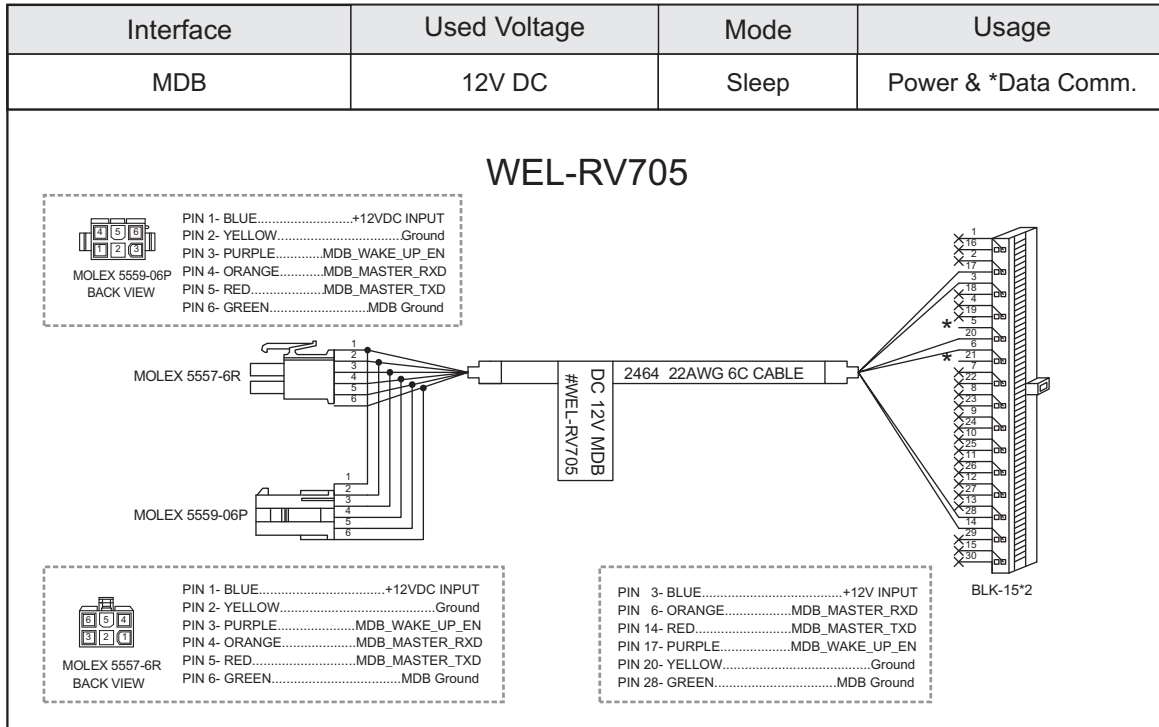

(Figure.3)

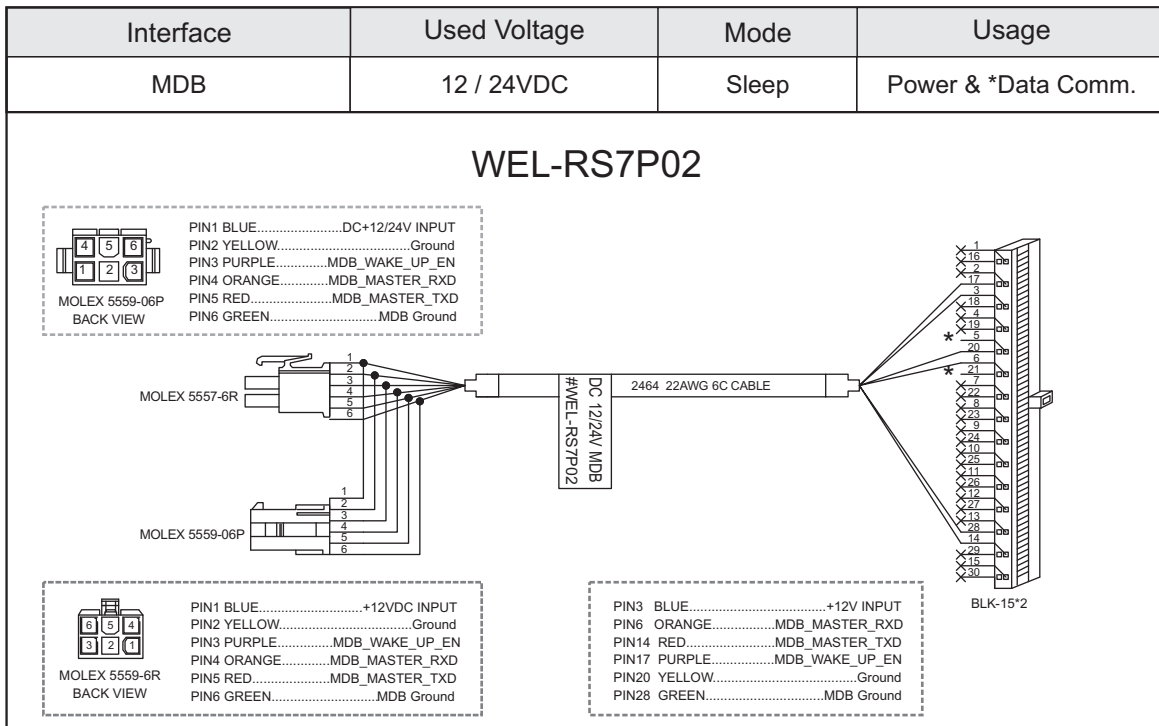

(Figure.4)

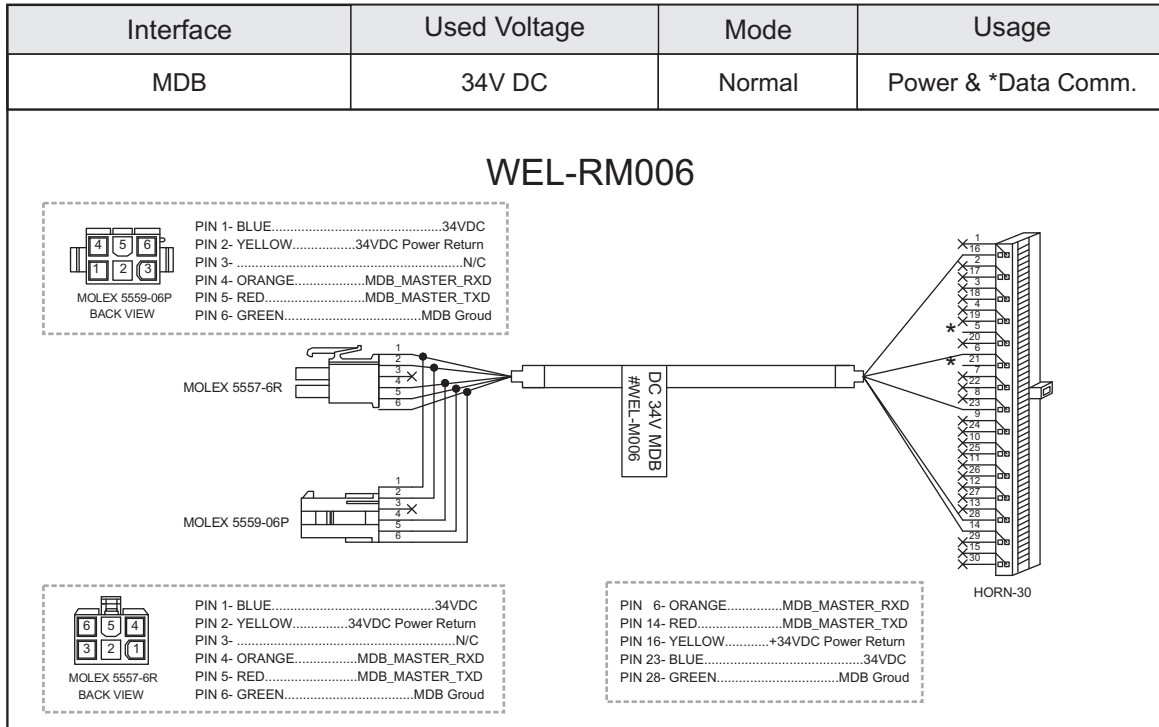

(Figure.5)

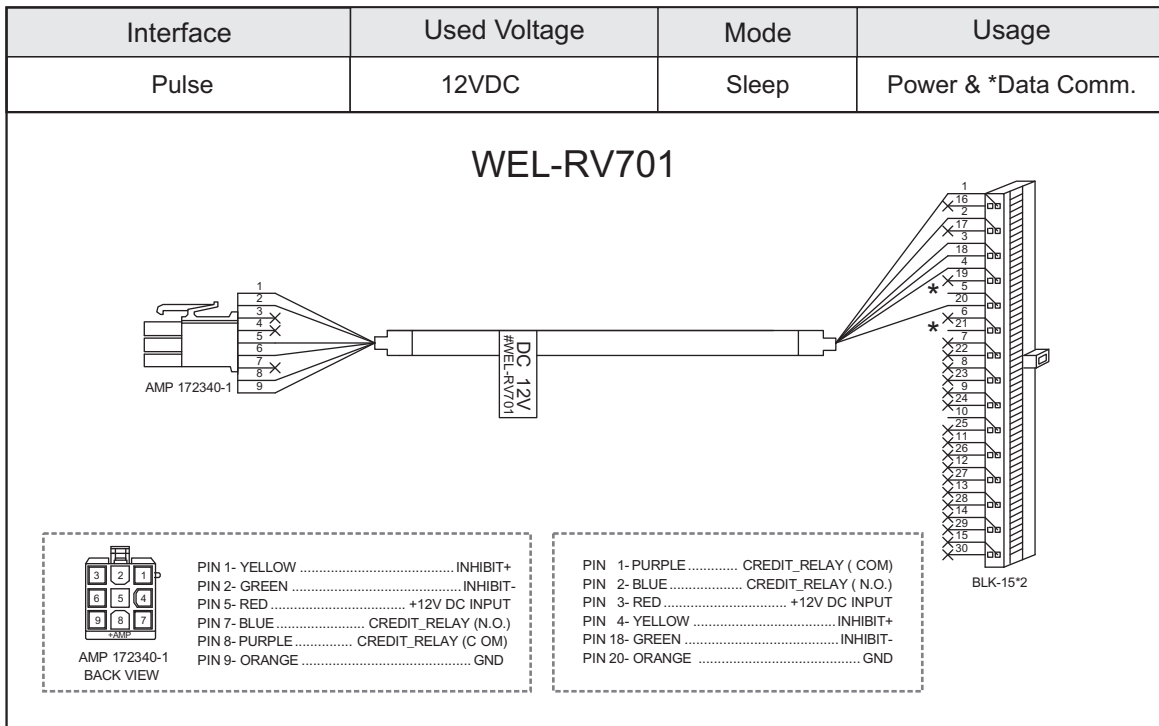

(Figure.6)

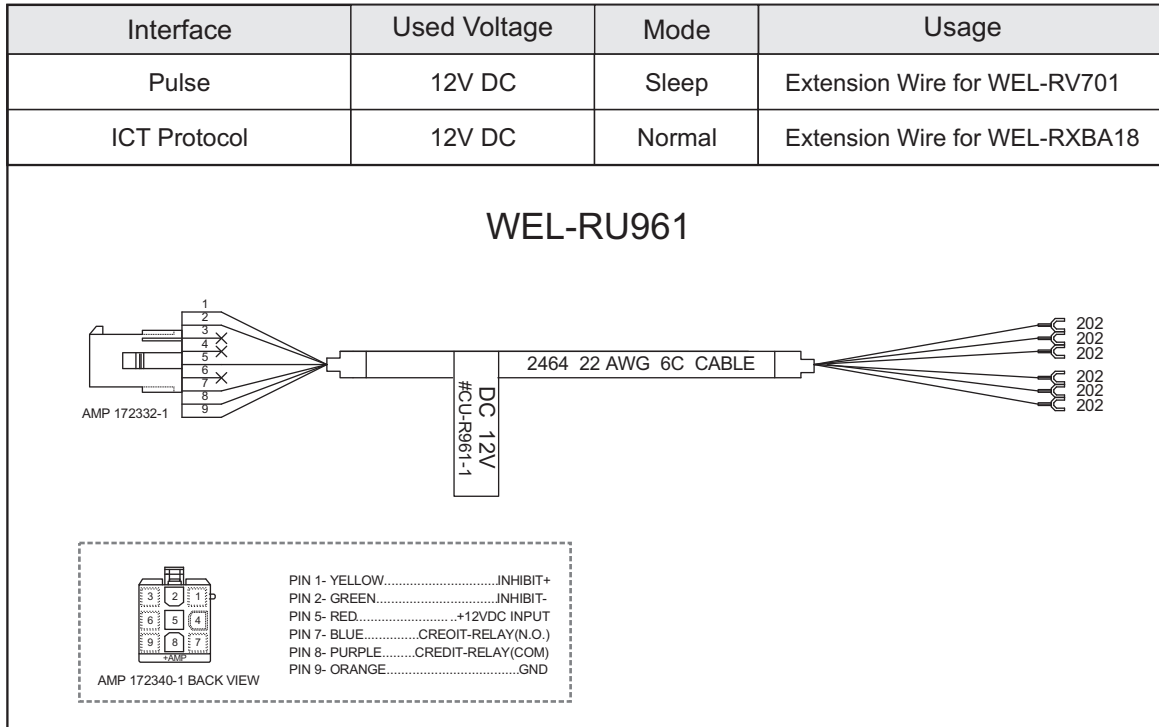

(Figure.7)

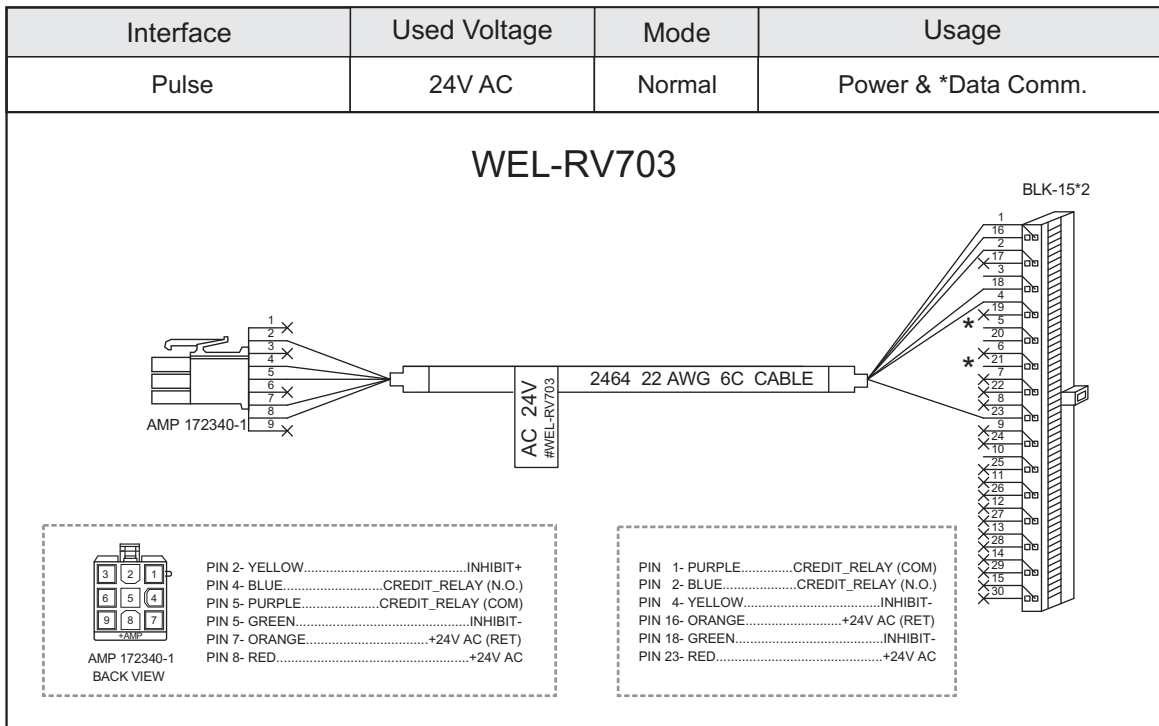

(Figure.8)

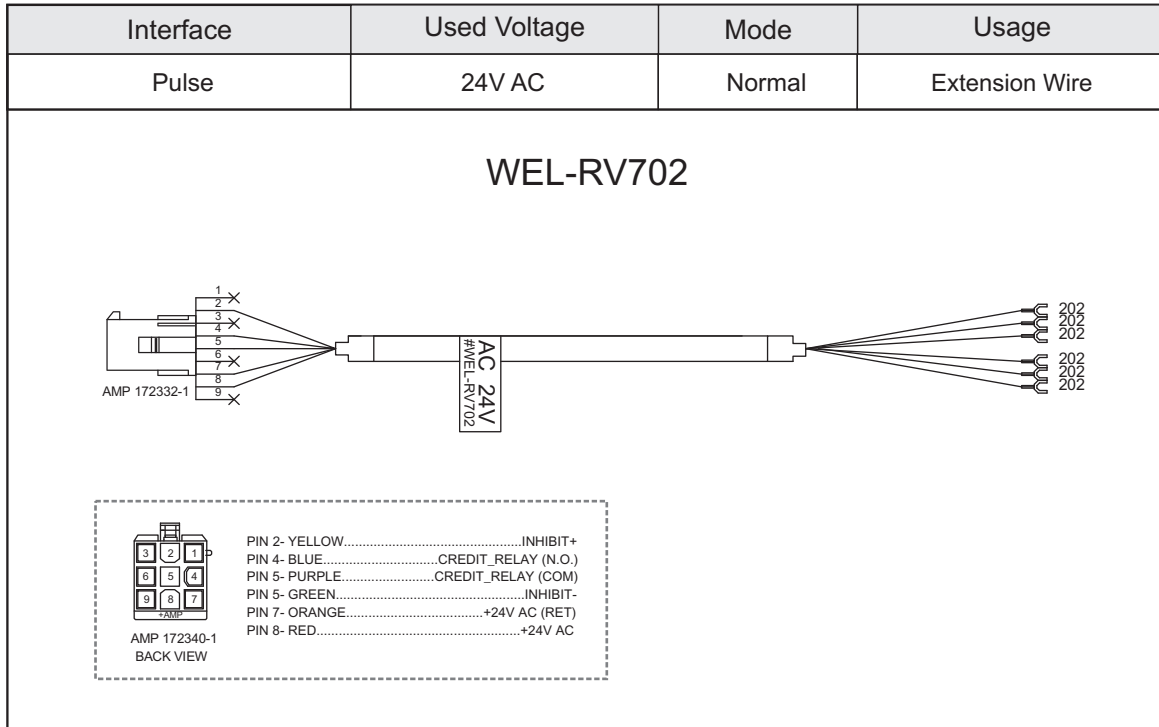

(Figure.9)

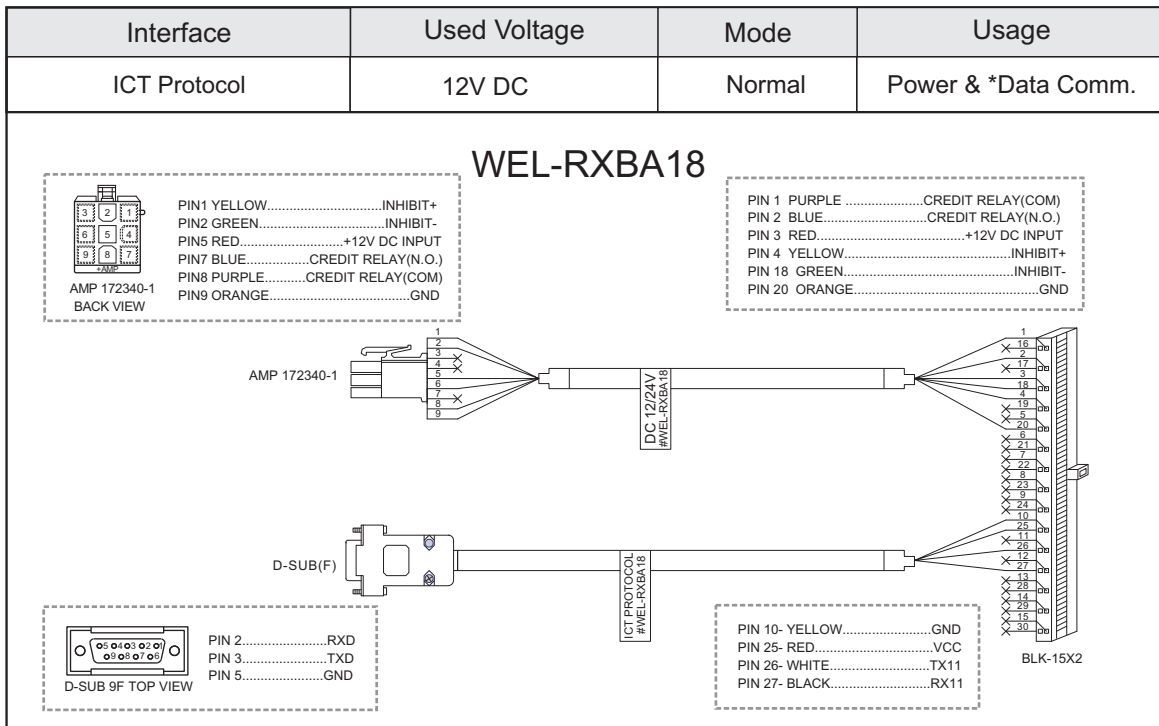

(Figure.10)

1-4. Bezel Styles

◆ **Standard-Bezel**

Part Number: A421900-R

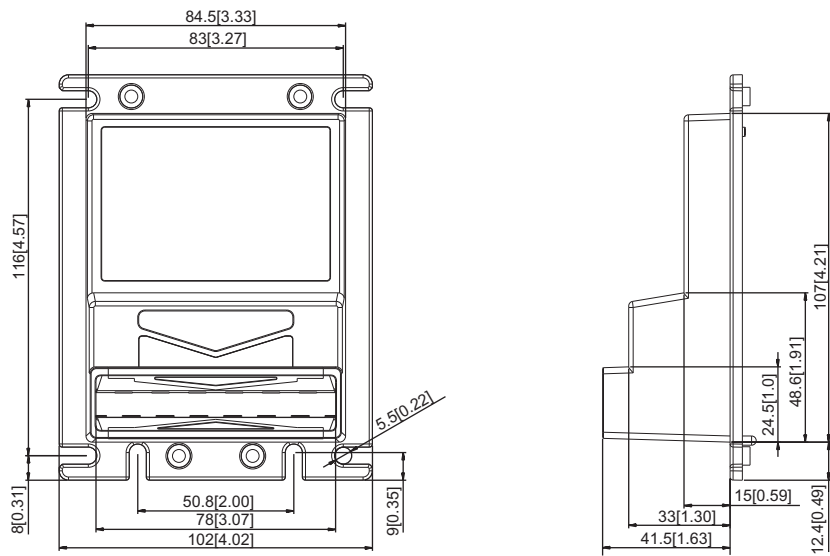

(Figure.11)

◆ **T-Bezel**

Part Number: A422000-R

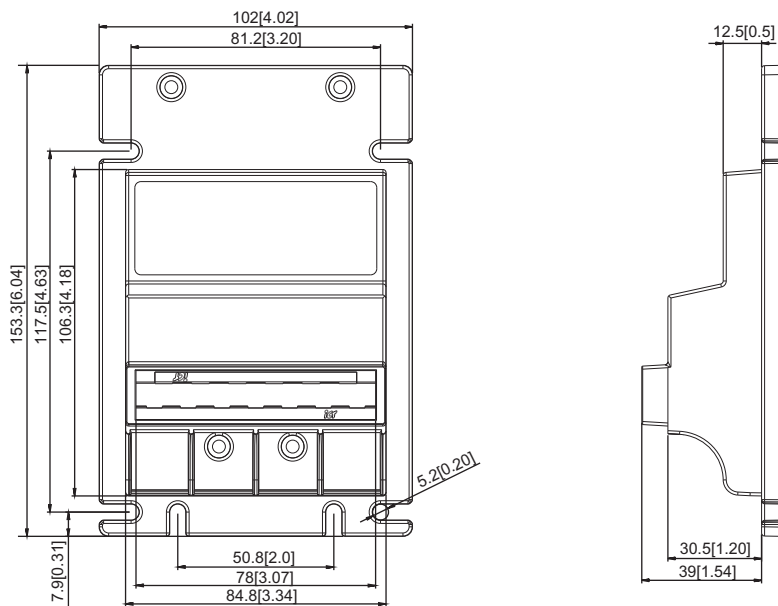

(Figure.12)

2. Software download and test

2-1. Download Firmware

2-1-1. PC ➡ BA

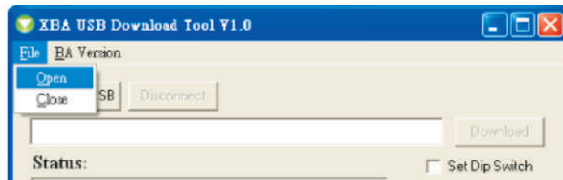

(Figure.13)

Step 1:

Select Firmware File: File -> Open

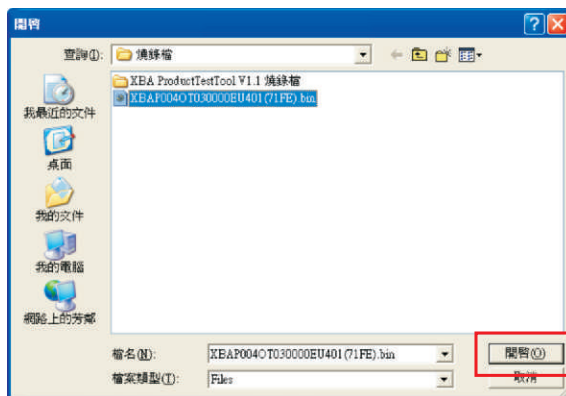

(Figure.14)

Step 2:

Select Firmware File & Press Open

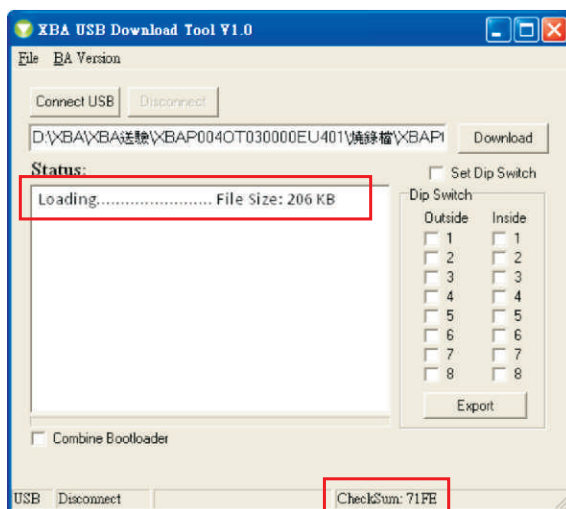

(Figure.15)

Step 3:

After opening , screen will display the file size and Checksum.

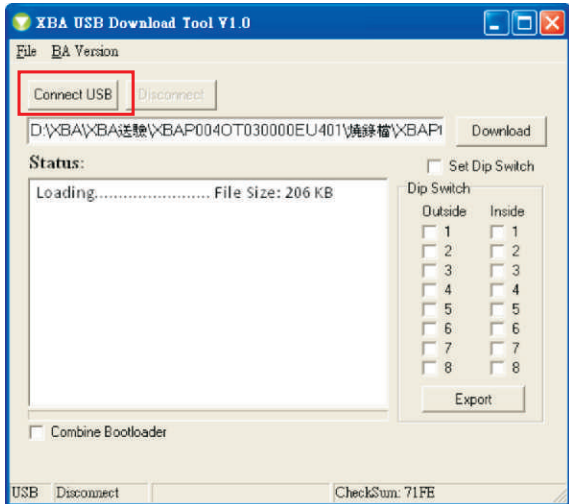

(Figure. 16)

Step 4:
Connection XBA & PC, turn on the XBA ,Press “Connect USB”

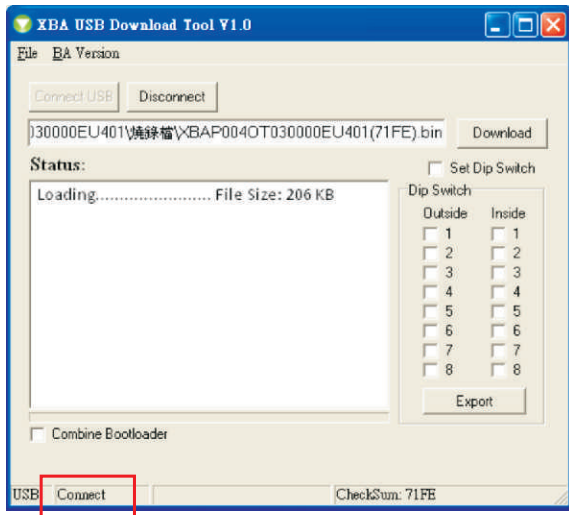

(Figure. 17)

Step 5:
Display Connect

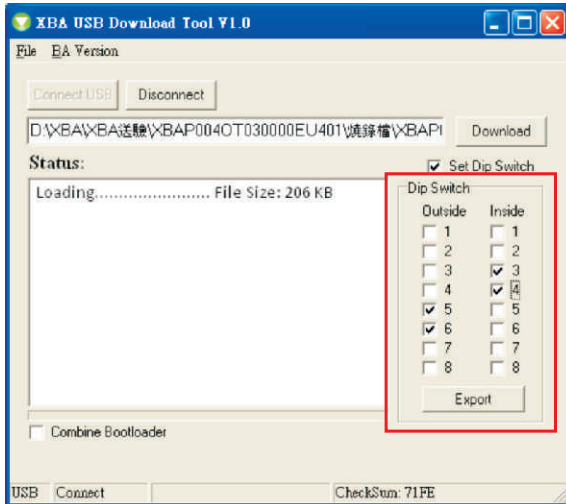

(Figure.18)

Step 6:

To set the DIP. Please select Set Dip Switch. And selecting DIP, Outside is a side DIP, Inside is an internal DIP.

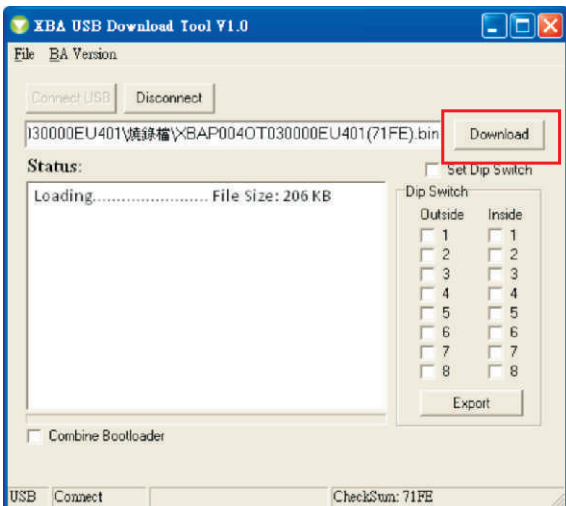

(Figure.19)

Press Download.

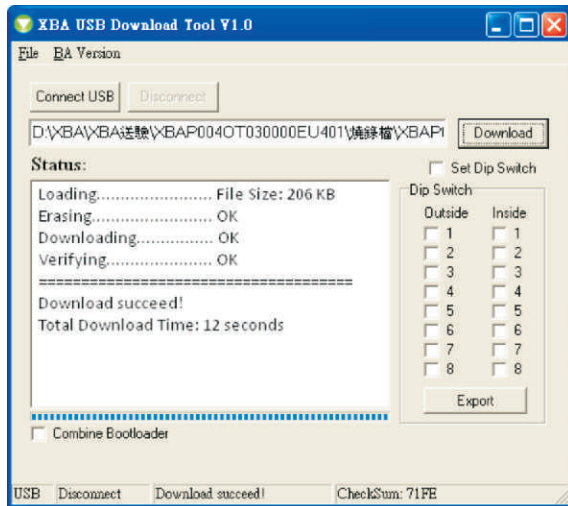

(Figure.20)

Step 7:
Download Success.

Step 8:
After rebooting BA.

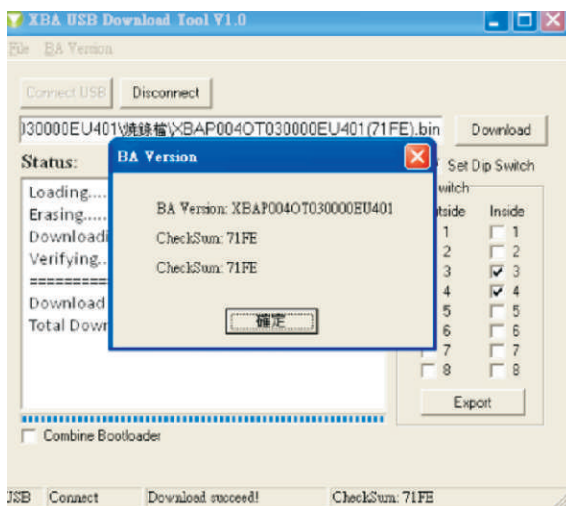

(Figure.21)

Step 9:
BA Version->Read Version. Check
BA Version & Checksum.

Step 2:

Enter the version and CheckSUM of this auto test tool.

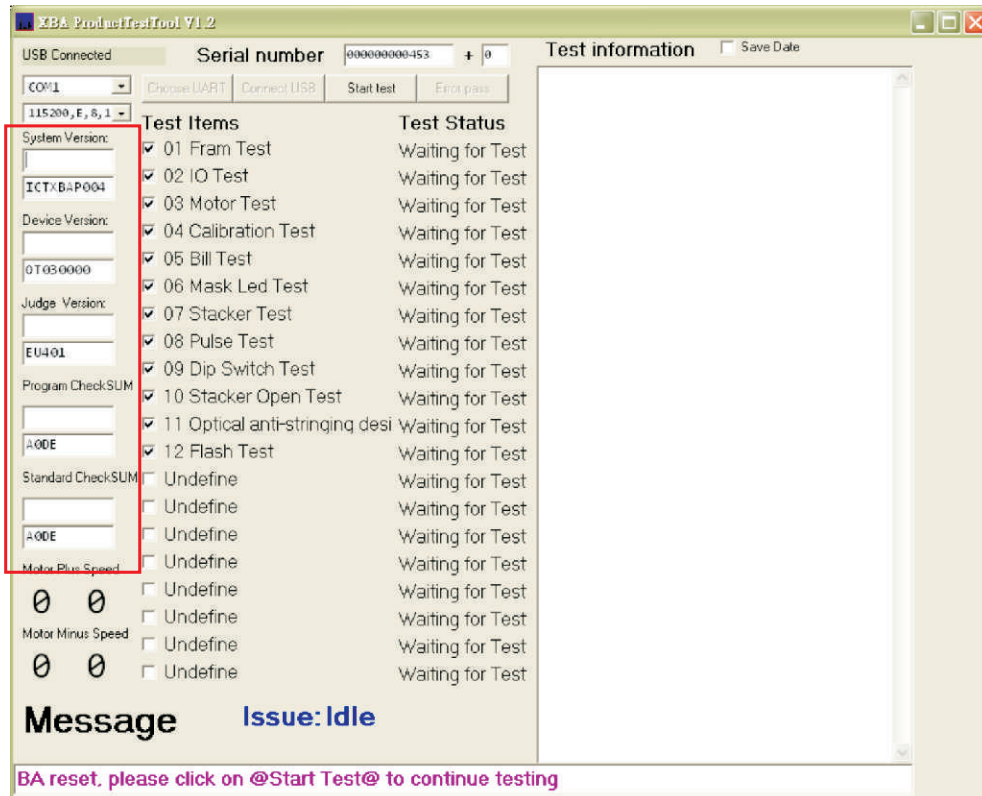

(Figure.24)

Step 3:

Press Connect USB. Message at upper left corner becomes “USB Connected”. It means the connection is successful. Turn off and turn on the BA and then the tool reads BA program version, shows the test items it will perform.

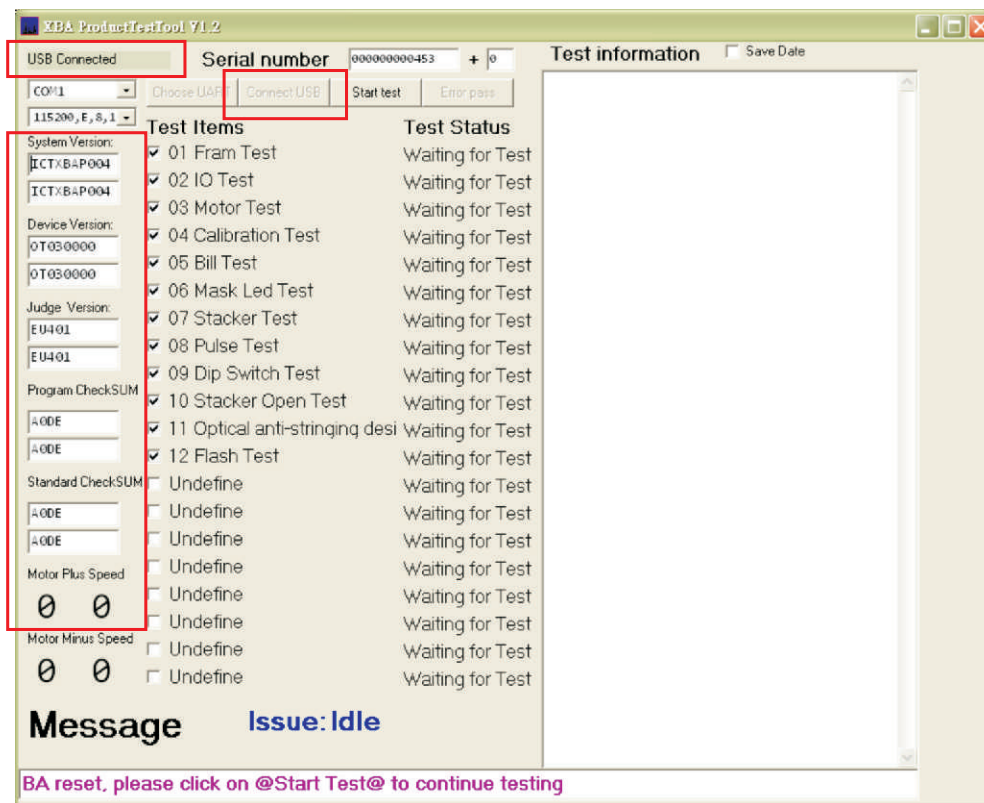

(Figure.25)

Step 4:

Press the **【Start test】** button, the tool starts testing in order.

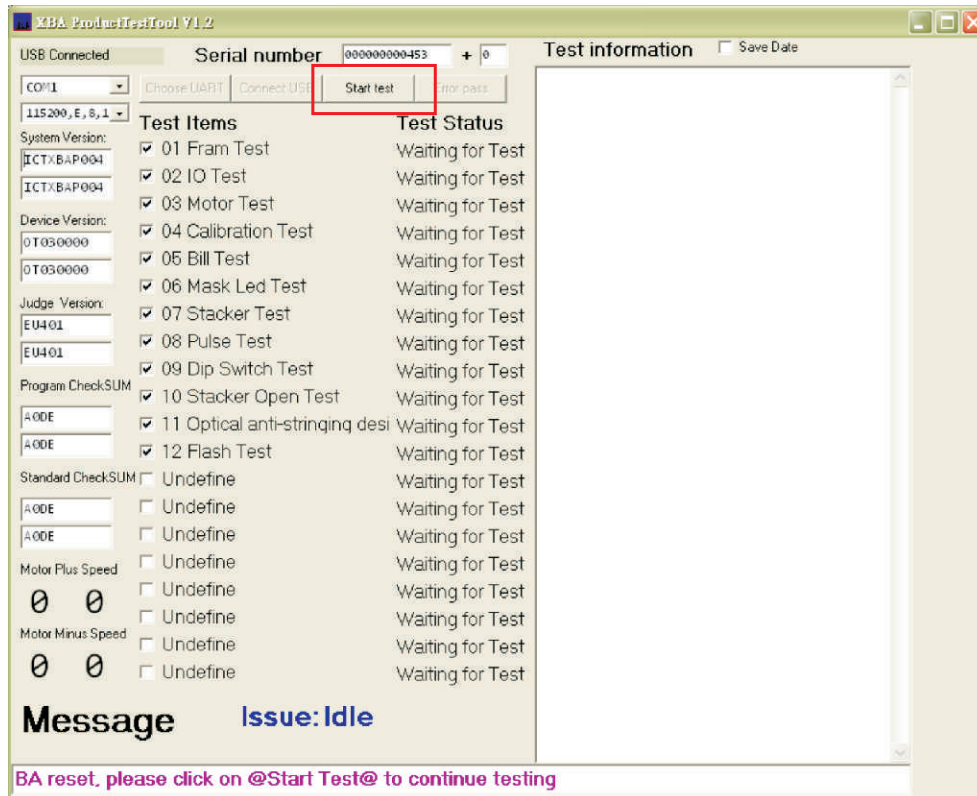

(Figure.26)

Step 6:
 Calibration Test: Please insert XBA series calibration card.

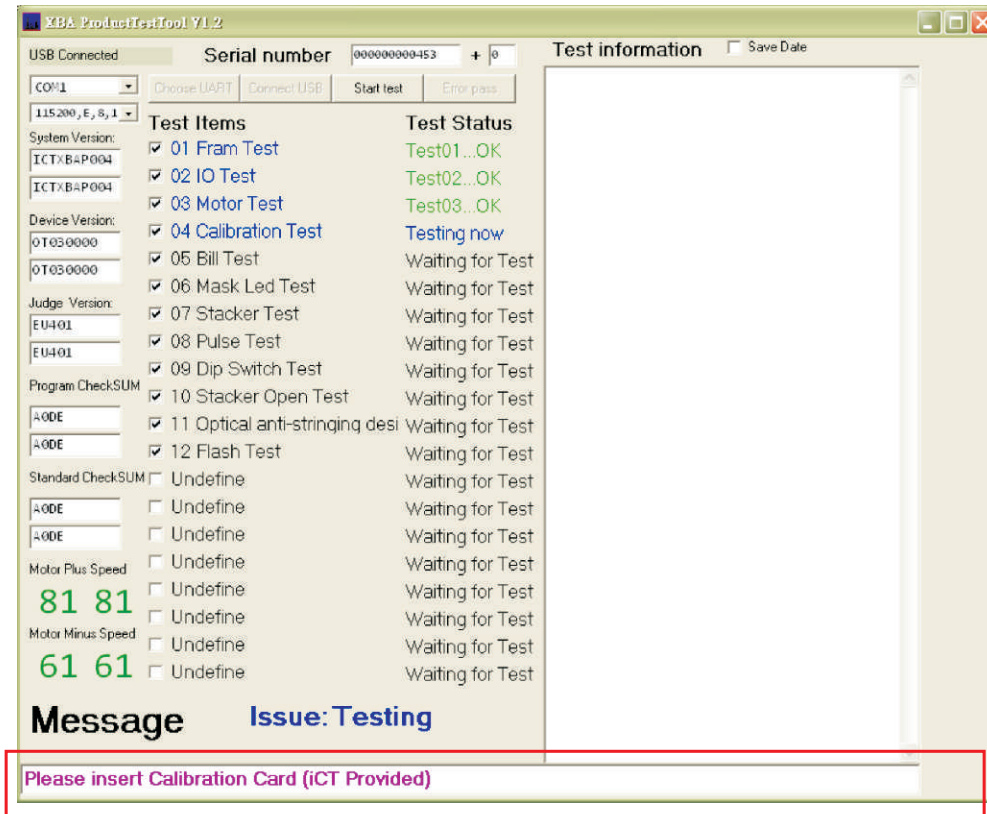

(Figure.28)

Step 7:

The message shows at the bottom left corner.

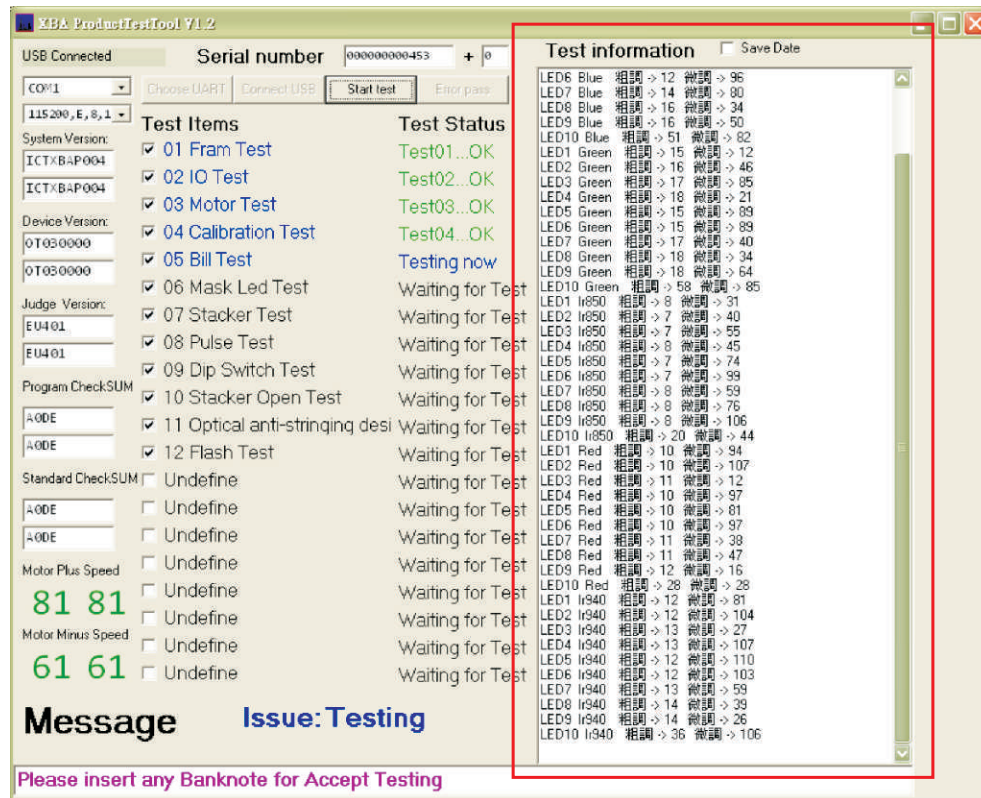

(Figure.29)

Step 9:

Mask LED Test: Please check if the LED flashed the correct color and press OK or NG in the pop-up window.

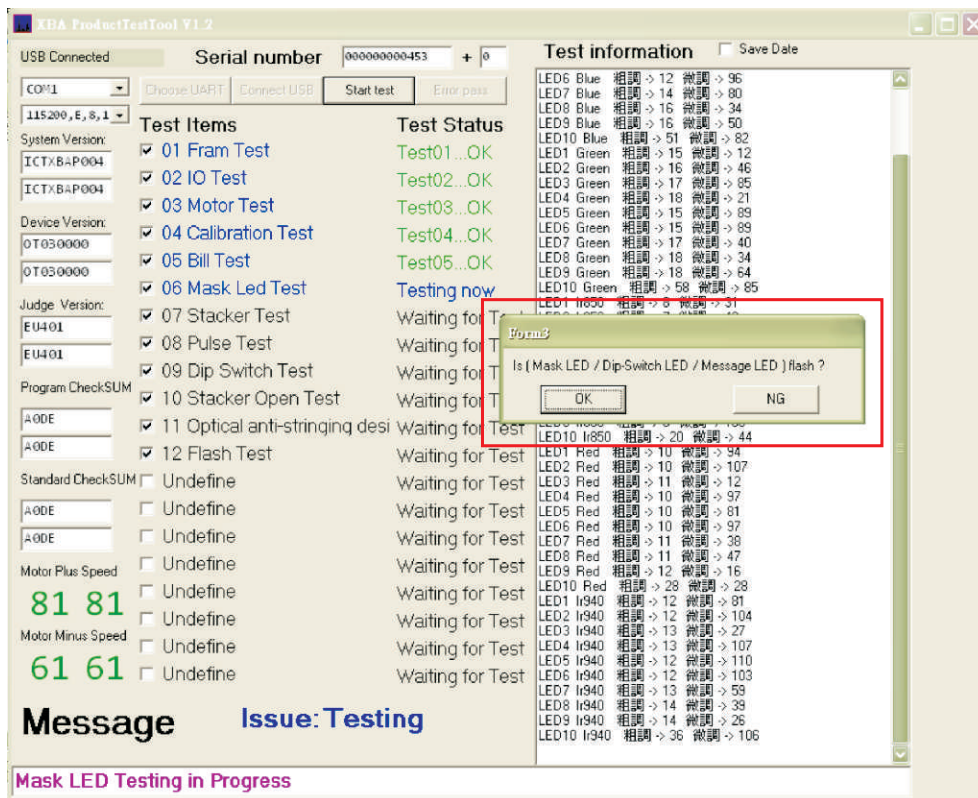

(Figure.31)

Step 10:

Stacker Test: Automatically perform stacking for one time, it will be listed as NG if error happens.

Step 11:

Pulse Test : Please check if the pulse the correct and press OK or NG in the pop-up window.

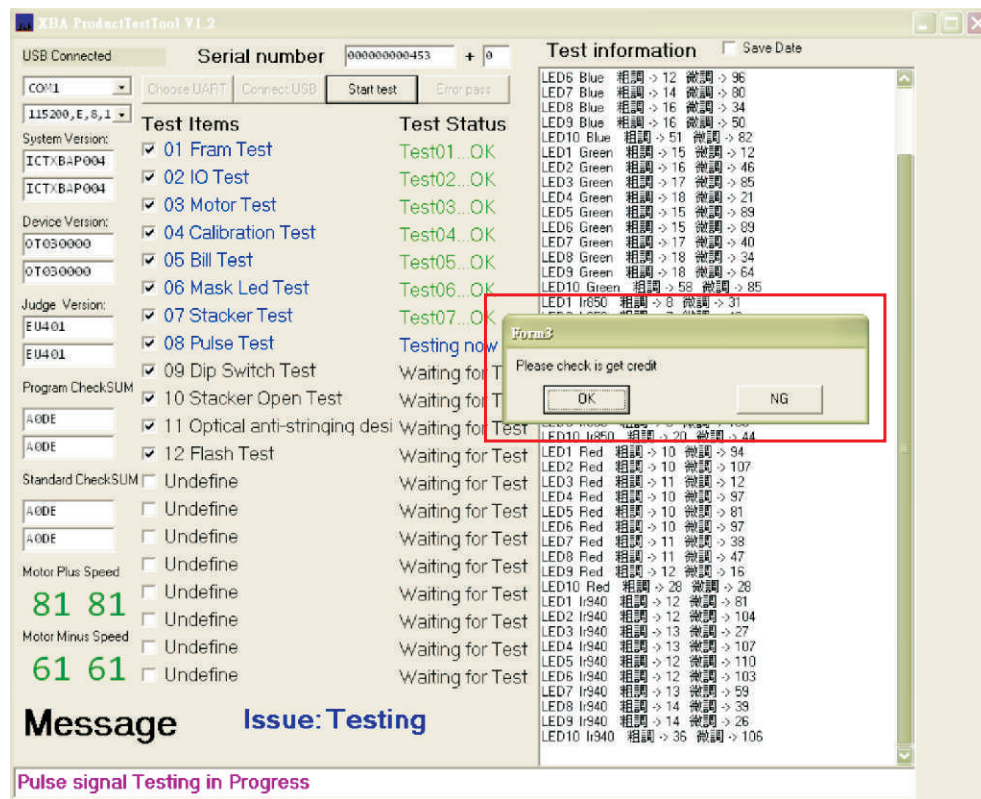

(Figure.32)

Step 12:

Dip Switch Test: Please turn on/off the DIP switch according to the message at the bottom left corner.

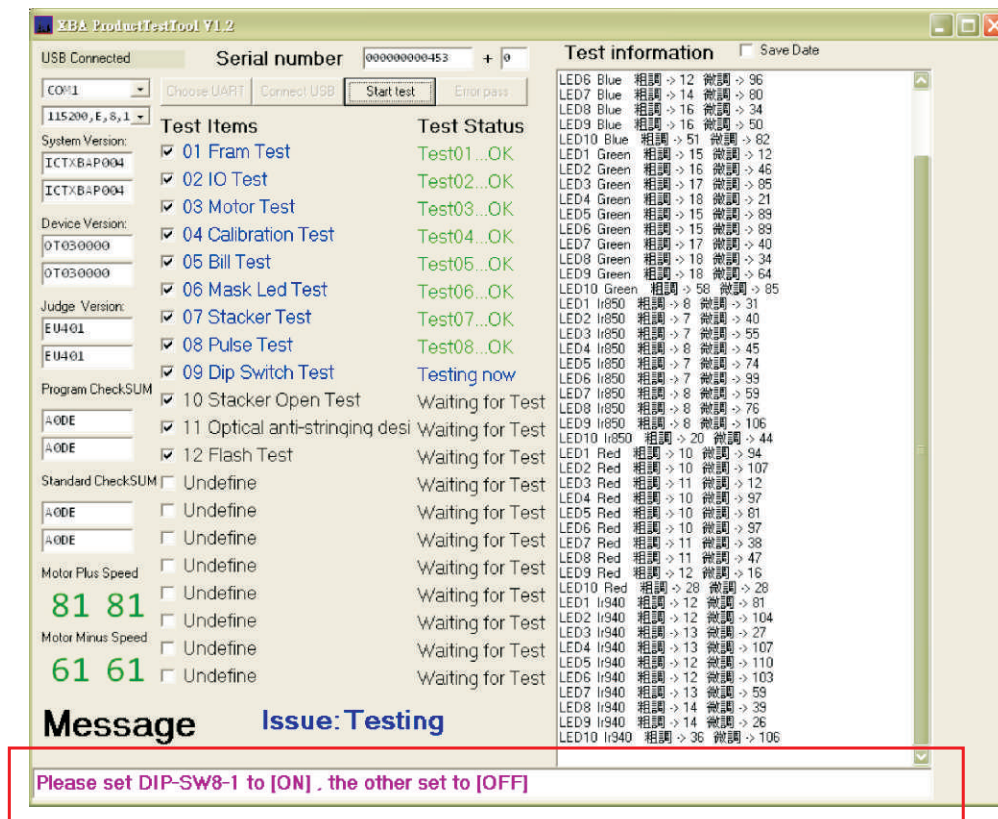

(Figure.33)

Step 13:

While testing “10 Cash box Test”, please remove and reinstall the cash box according to the message at the bottom left corner.

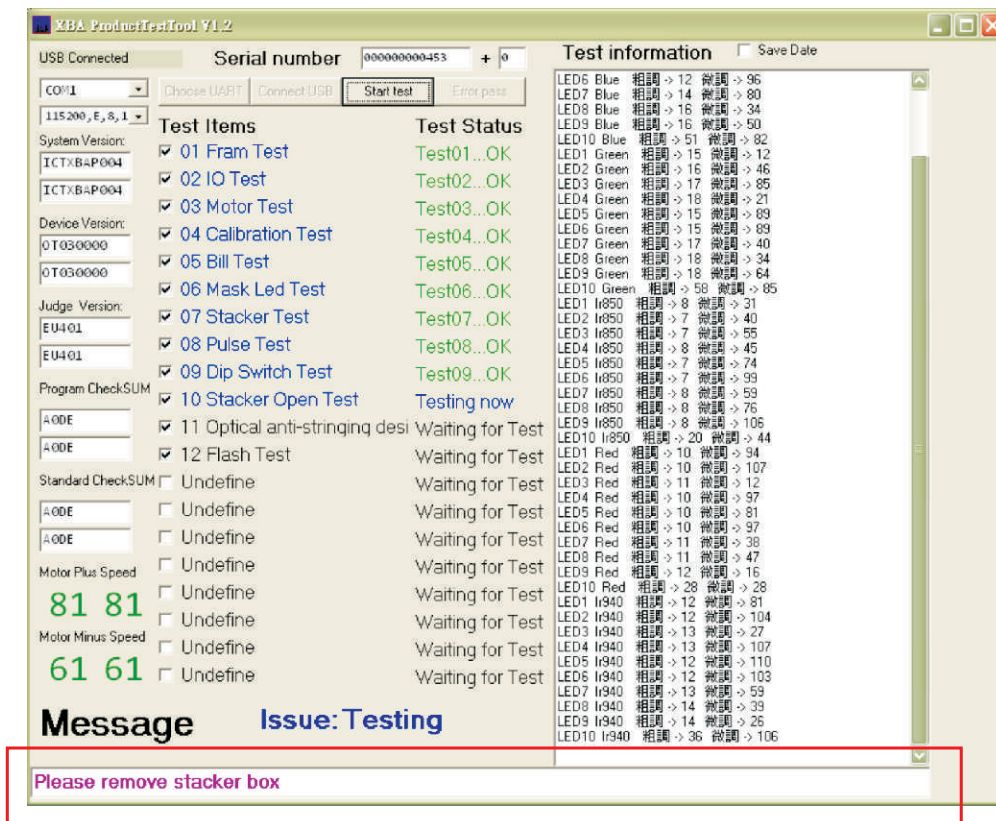

(Figure.34)

Step 14:

Optical anti-stringing design Test, test Optical anti-stringing function. It will appear “NG” if error happens.

Step 15:

Flash Test There will be error message in the Test information if the read/write error happens.

The “Issue” shows the result after the entire test:

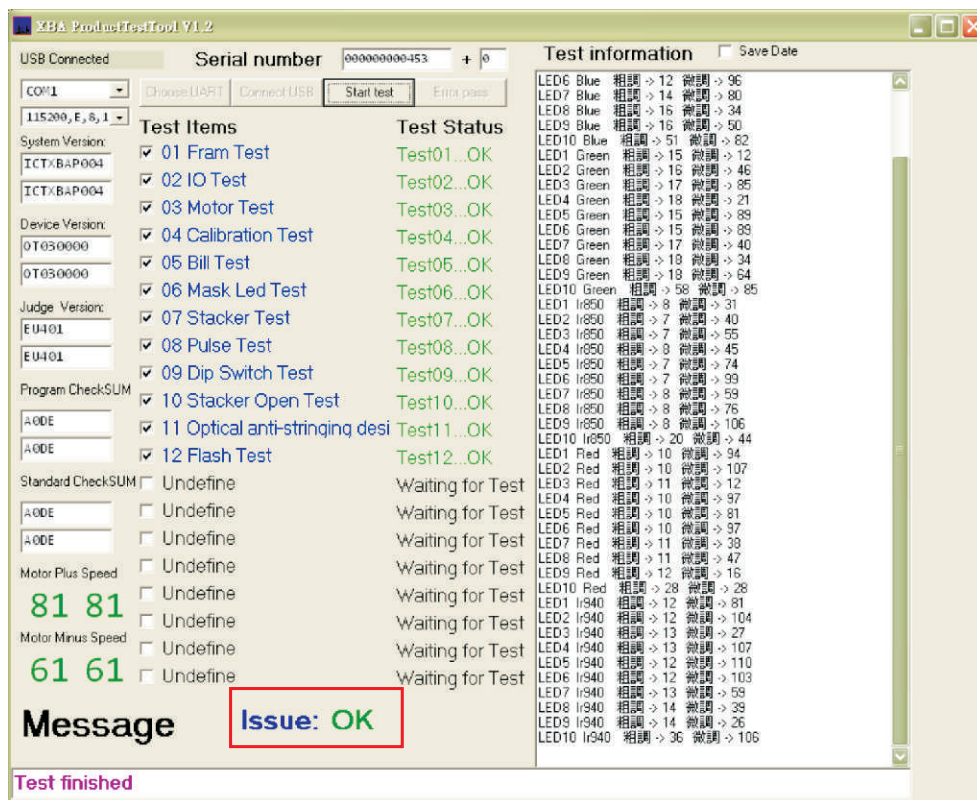

(Figure.35)

2-3. Component Names

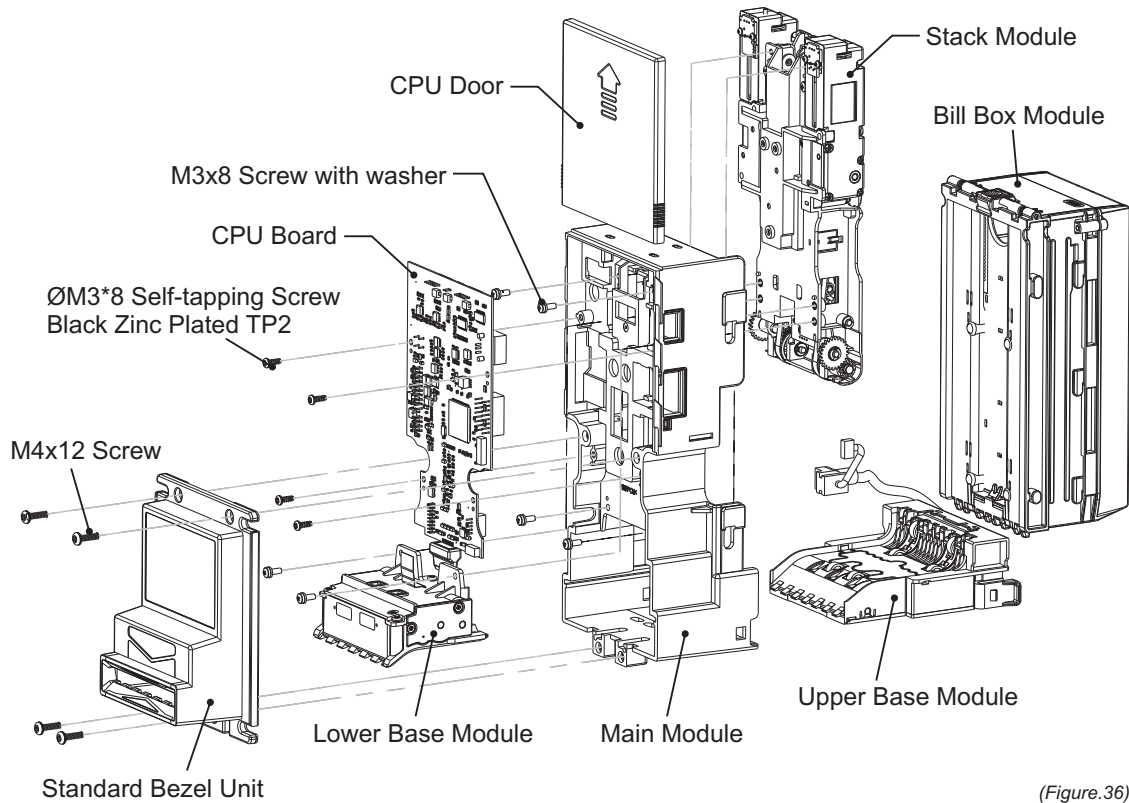

(Figure.36)

2-4. Assembling Procedure

2-4-1. Disassembly Procedure

Step 1:

Remove bill box.

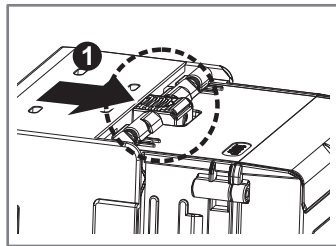

(Figure.37)

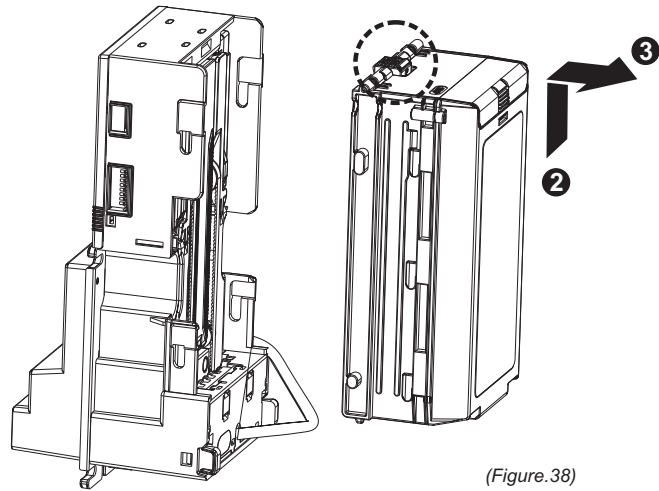

(Figure.38)

Step 2:

Loosen four screws to remove the bezel.

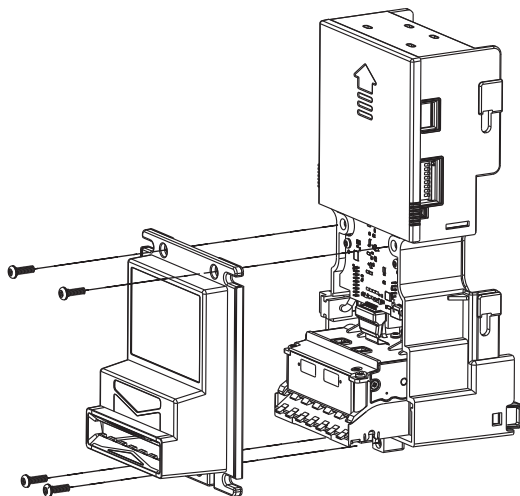

(Figure.39)

Step 3:

Remove the cover plate of main unit.

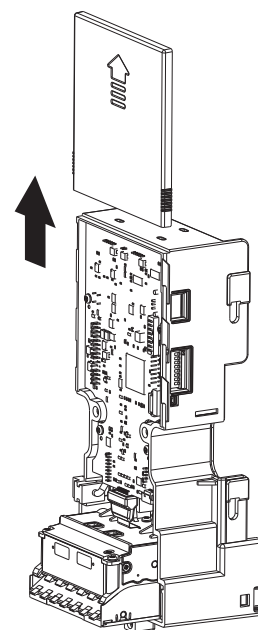

(Figure.40)

Step 4:
Loosen four screws to remove cpu board.

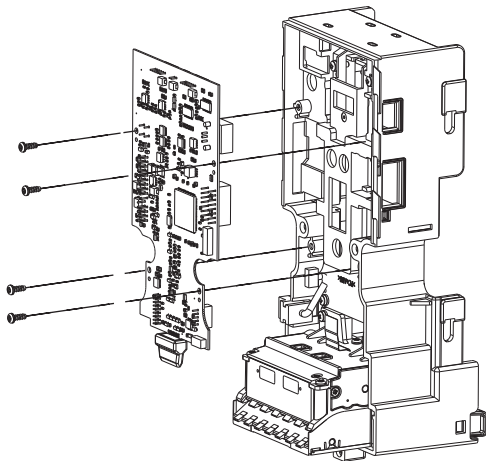

(Figure.41)

Step 5:
Press the snap on both left and right sides to remove the upper base.

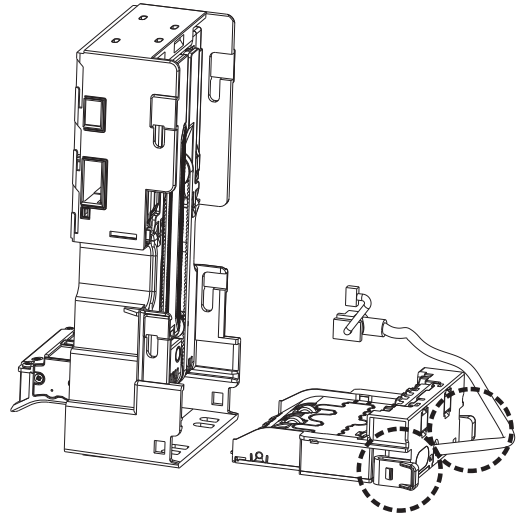

(Figure.42)

Step 6:
Loosen two screws to remove the Lower Base.

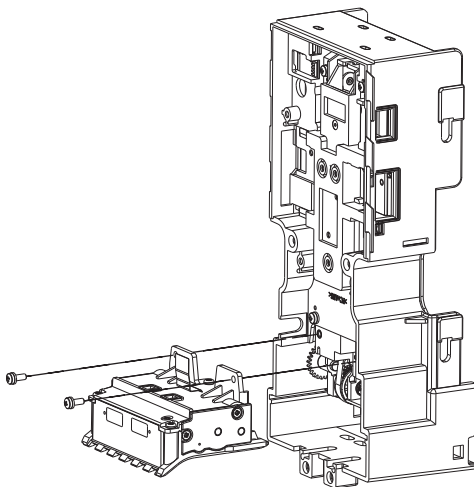

(Figure.43)

Step 7:
Loosen four screws to remove transmission module.

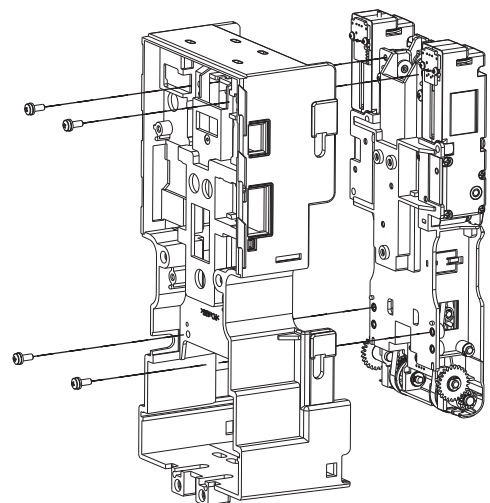

(Figure.44)

Step 8:

1. Remove the sensor unit top cover.

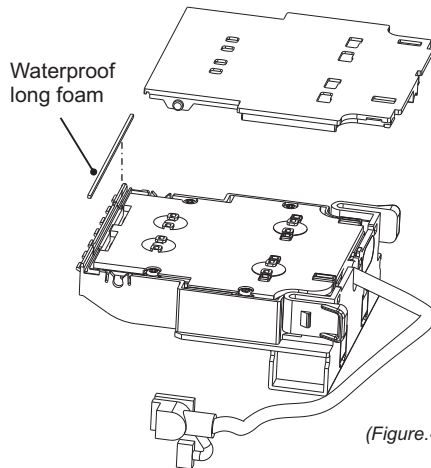
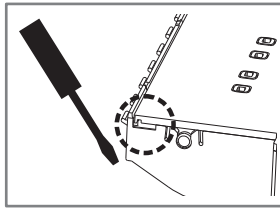

(Figure.45)

2. Remove Upper Base Waterproof Foam. Remove Upper Base Baffle Board.

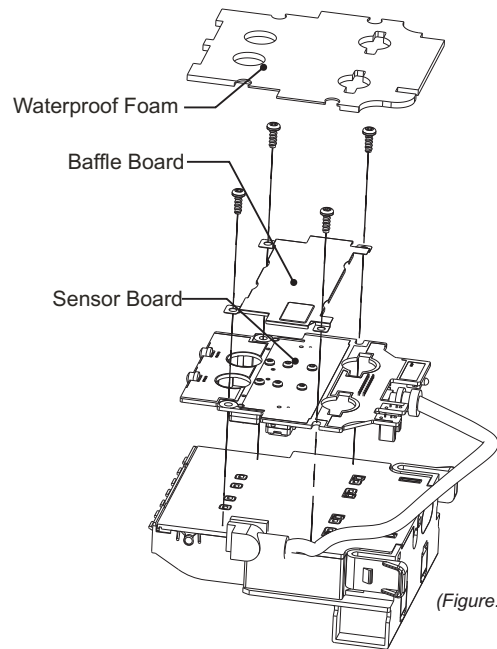

(Figure.46)

3. Disassembly IR LED/ Sensor mirror.

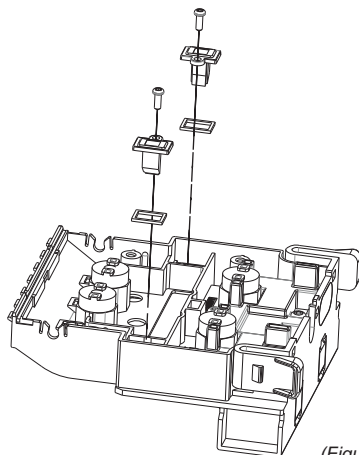

(Figure.47)

4. Disassembly security hook.

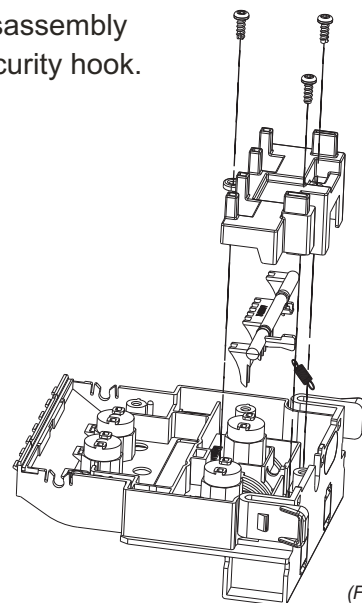

(Figure.48)

Step 9:

1. Loosen three screws to remove the Lower Base cover.

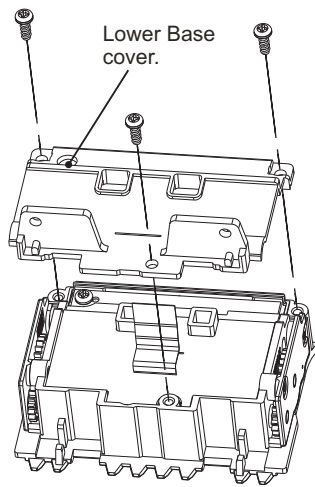

(Figure.49)

2. Remove Lower Base Water Proof Rubber. Loosen three screws to remove the LED board.

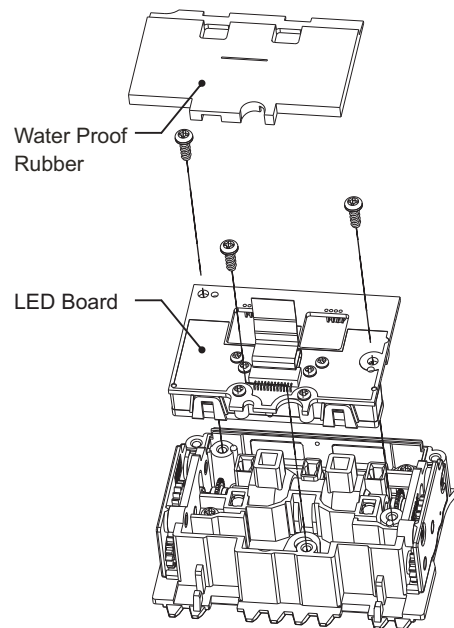

(Figure.50)

3. Loosen four screws on the side to remove the Lower Base Gear Cover Plate.

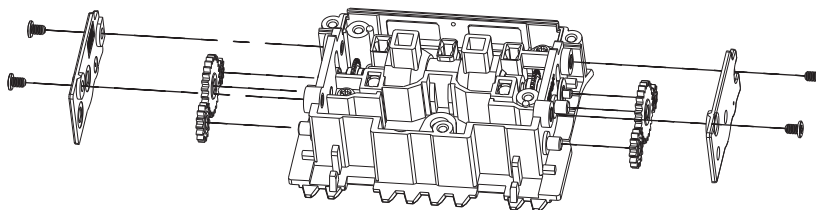

(Figure.51)

4. Loosen two screws to remove Lower Base Waterproof cover.

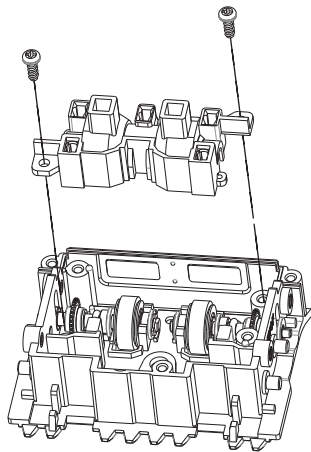

(Figure.52)

5. Remove two Plastic Axle Bush to take rubber wheels out.

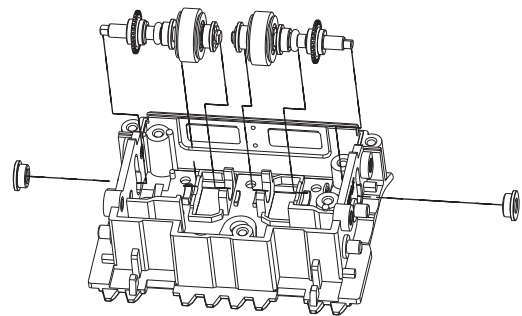

(Figure.53)

Step 10:

1. Disassembly transmission module.
Loosen screw to remove Sensor board.

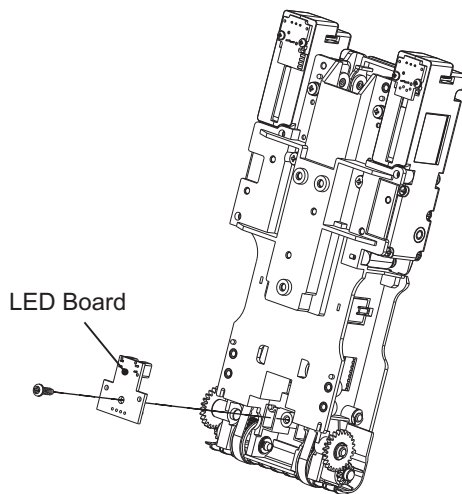

(Figure.54)

2. Loosen two screws to remove Block structure Rails.

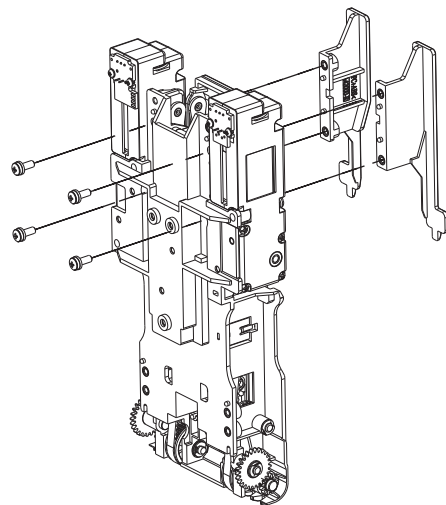

(Figure.55)

3. Loosen four screws to remove Bill Sending Motor Set.

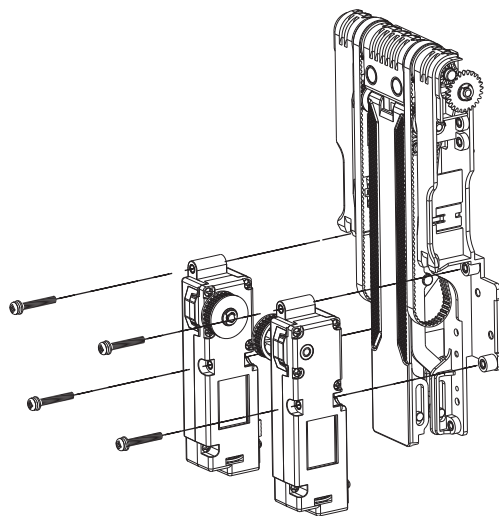

(Figure.56)

4. Remove E-ring. Pull the Belt Axle out. Remove Belt Roller.

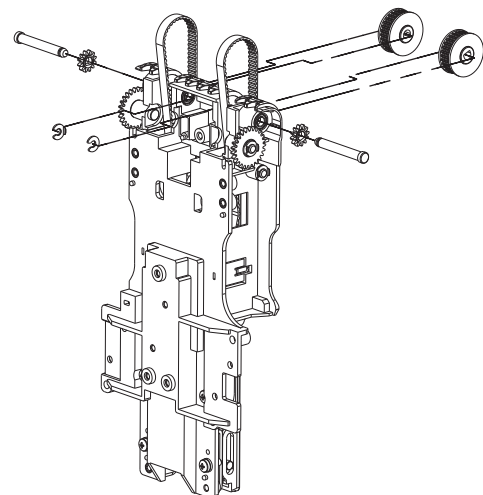

(Figure.57)

5. Rise Stacker Board up. Remove E-ring. Remove Stacker Board.

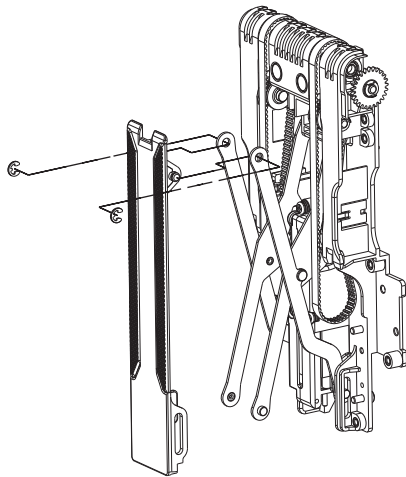

(Figure.58)

6. Loosen three screws to remove Stacker Motor.

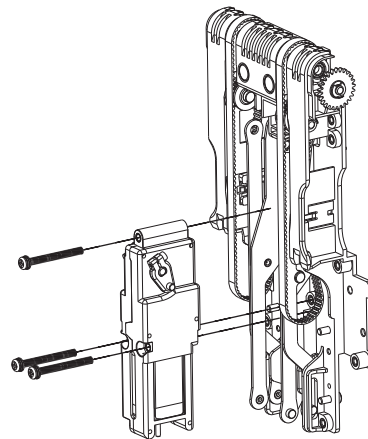

(Figure.59)

7. Remove E-ring. Pull the Belt Axle out. Remove Belt & Belt Roller.

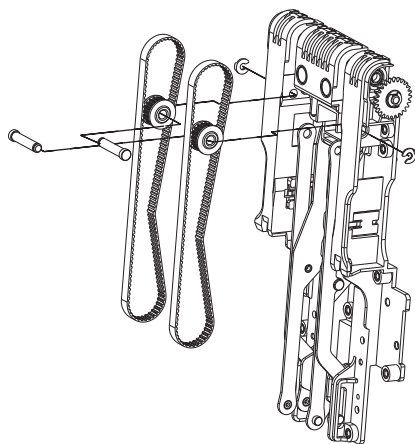

(Figure.60)

3. Operation

3-1. Operation Flowchart

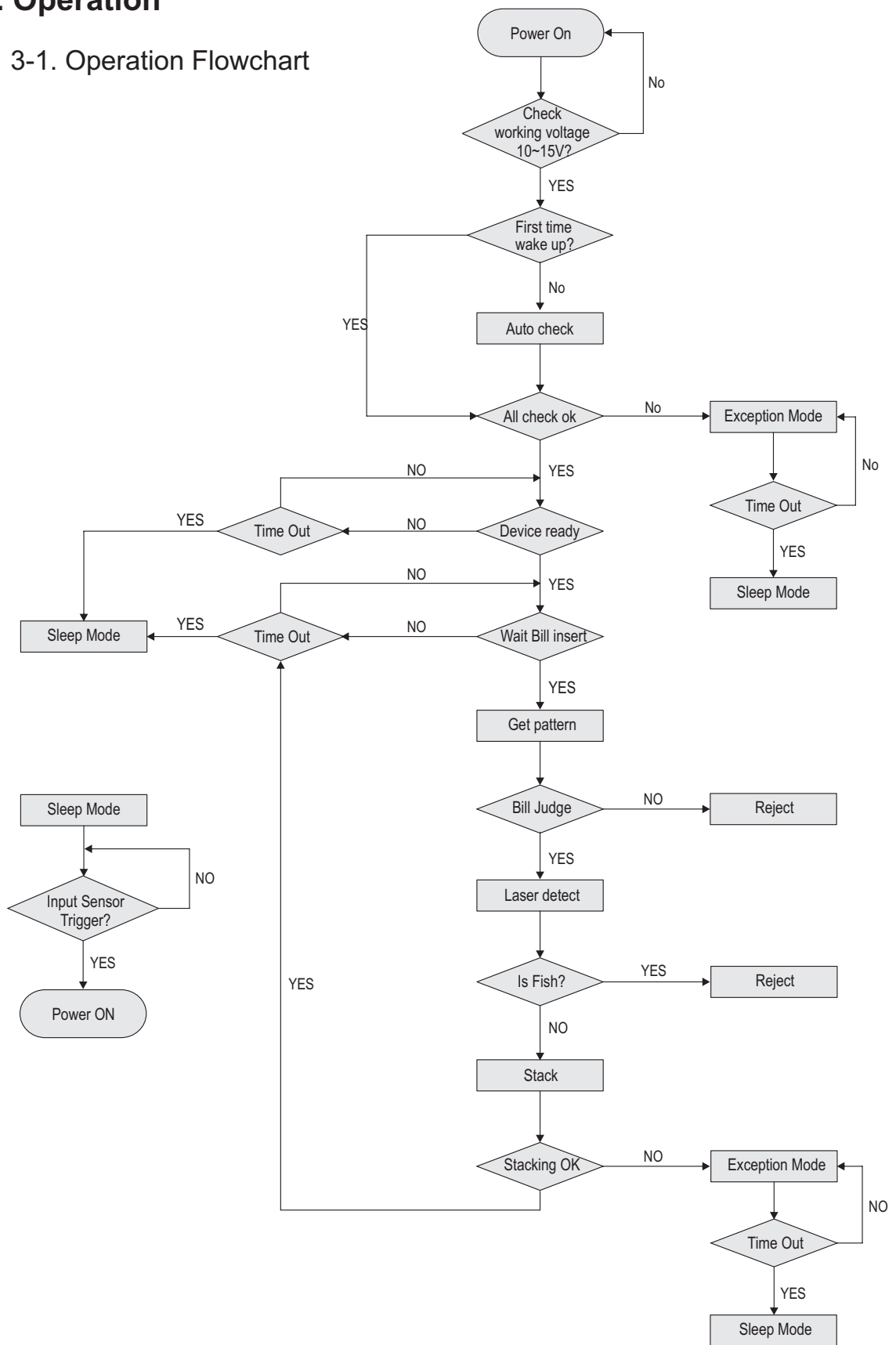

(Figure.61)

3-2. I/O Circuit

Pulse Interface.

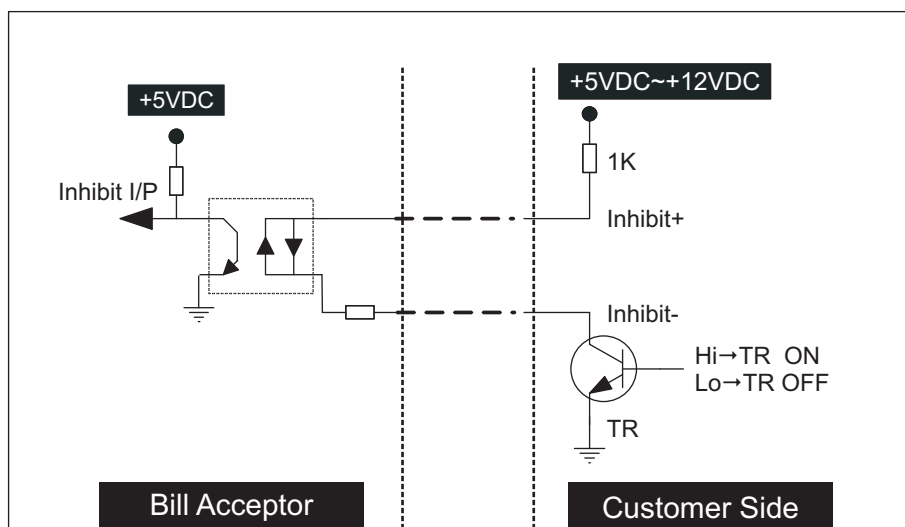
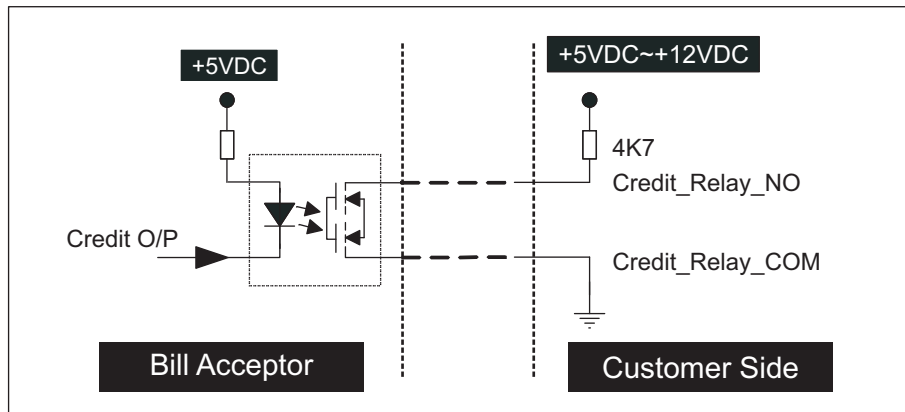
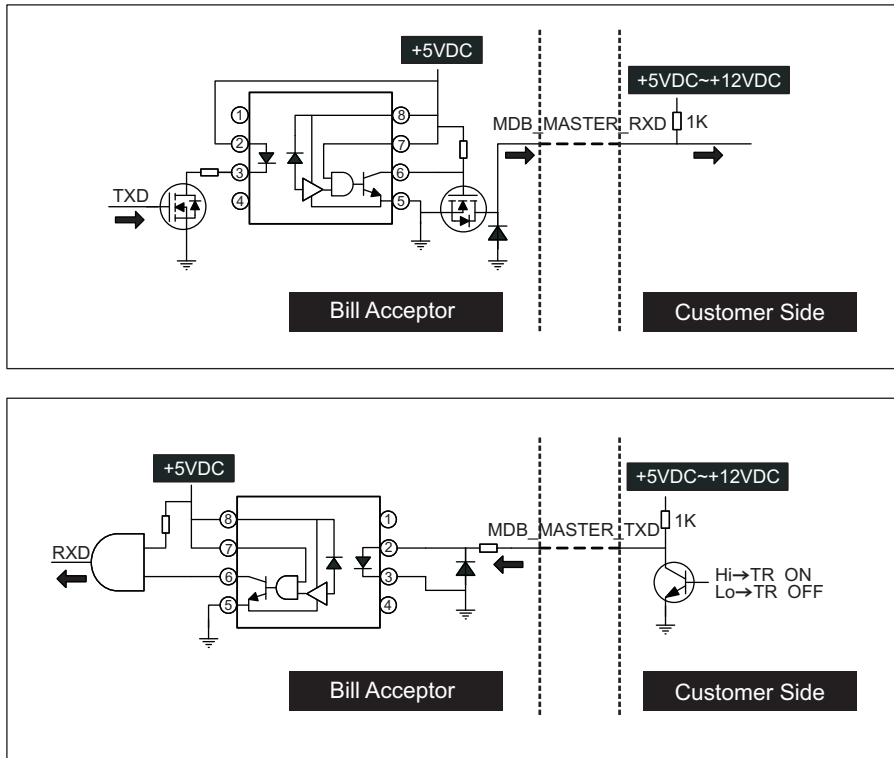

Table.11

BA Status	DIP SW Setting	Control Signal
Inhibit	Inhibit Active	Low
		High
Enable	Inhibit Active	Low
		High

(Figure.62)

MDB Interface.



(Figure.63)

ICT Interface.

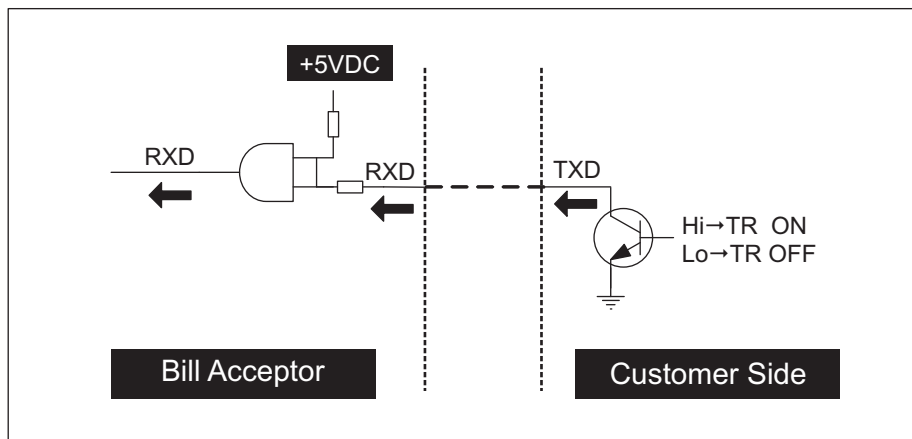
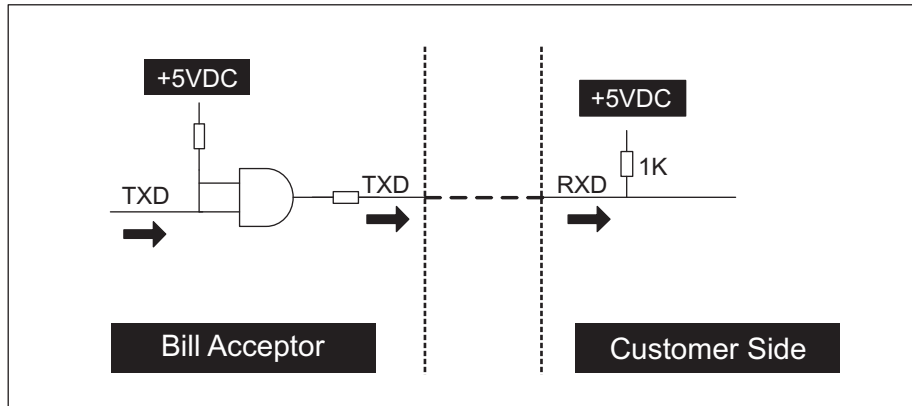

(Figure.64)

4. Maintenance

To make sure the bill acceptor always works smoothly, please clean the internal parts regularly.

To clean the internal parts:

1. Press the buttons on the sides of bill path and pull the unit out.

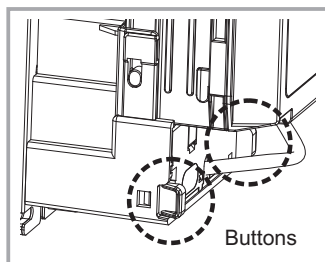

(Figure.65)

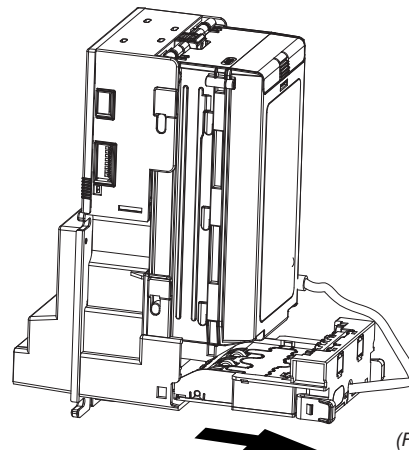

(Figure.66)

2. Use a soft, dry cloth or towel to clean the bill path and sensors.

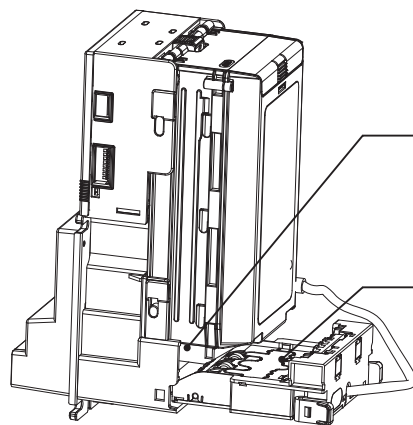

(Figure.67)

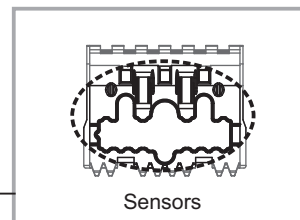

(Figure.68)

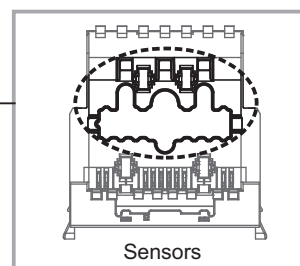

(Figure.69)

	Maintenance Notice	
	<i>(Any improper maintenance will result invalid warranty.)</i>	
	Recommended	Mild, non-abrasive, soap water.
	DO NOT USE	Organic solvent , Alcohol, Volatility liquid.

5. Trouble Shooting

5-1. Introduction

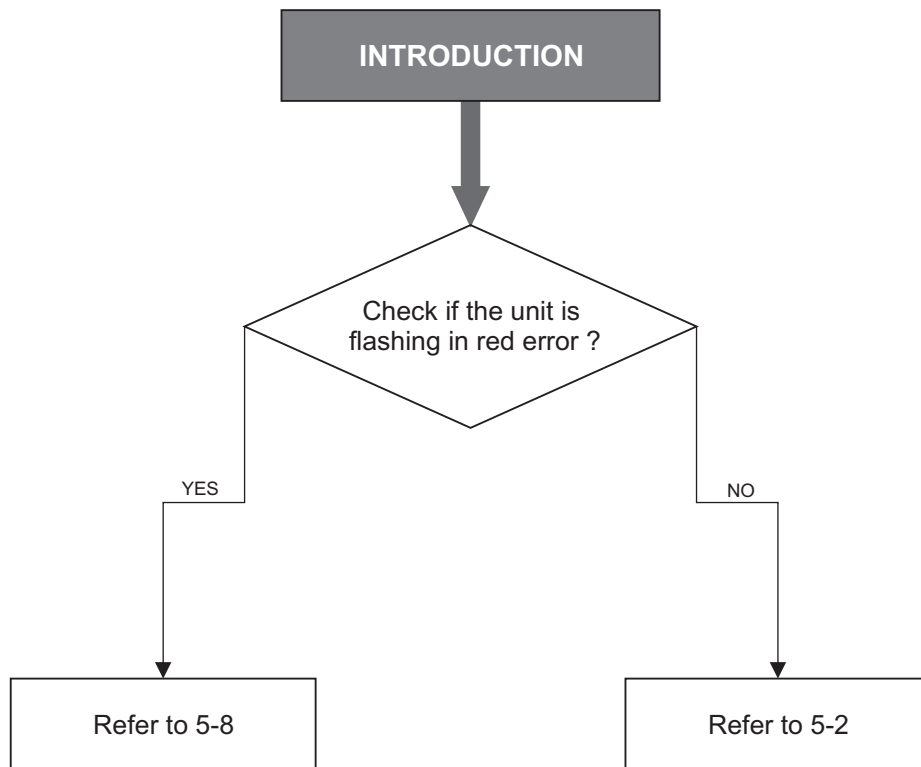

(Figure.70)

5-2. Failed to Power Up

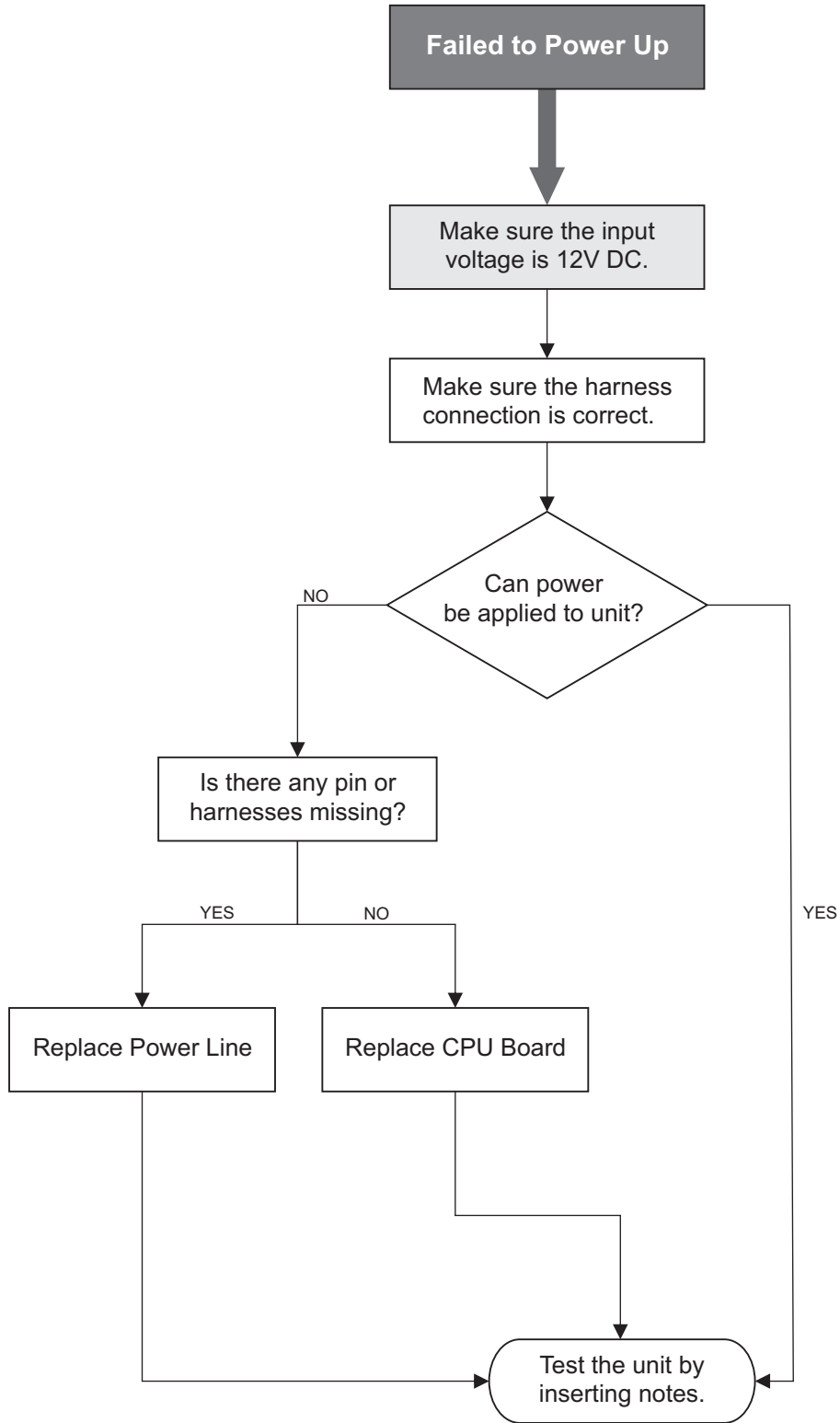

(Figure.71)

5-3. Failed to Communicate

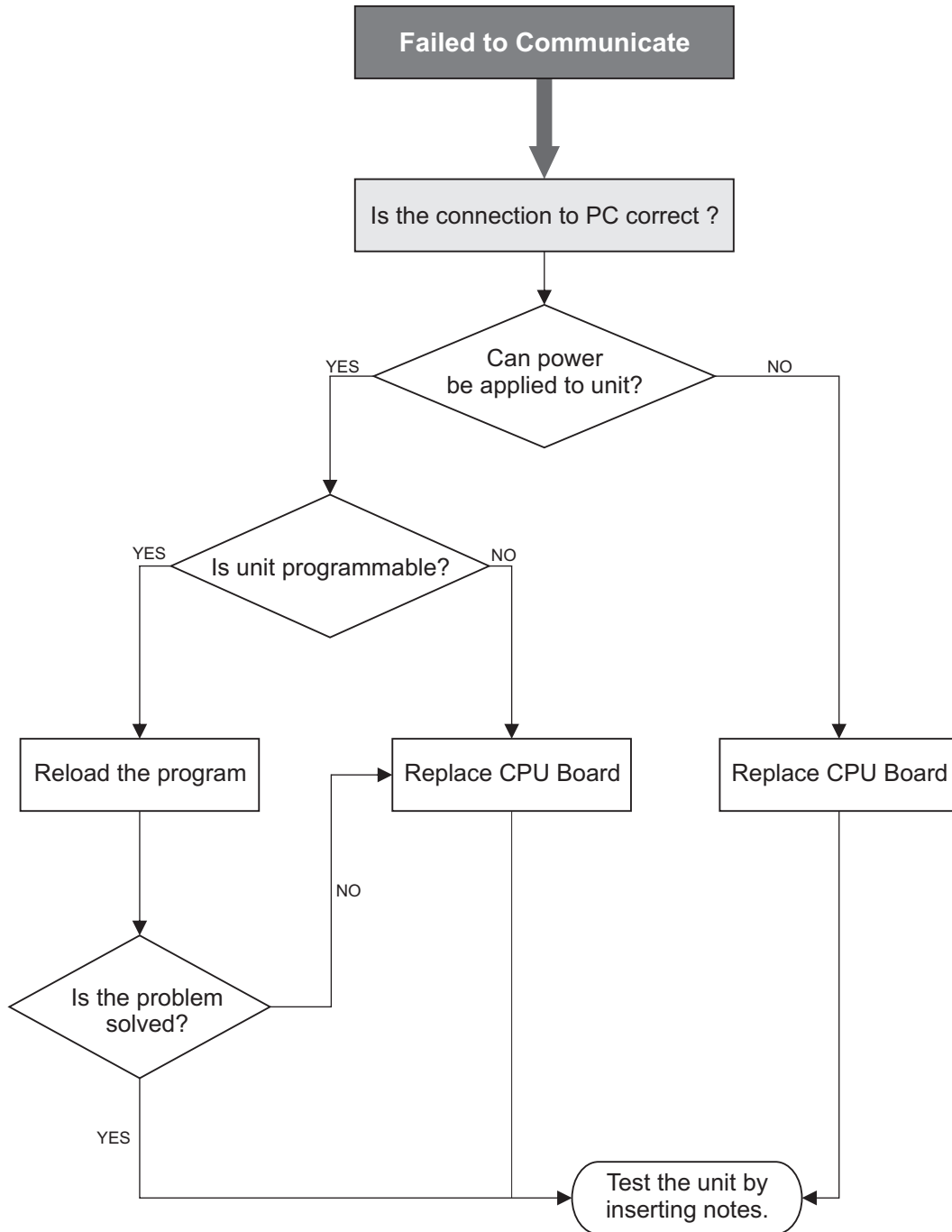

(Figure.72)

5-4. Low Acceptance

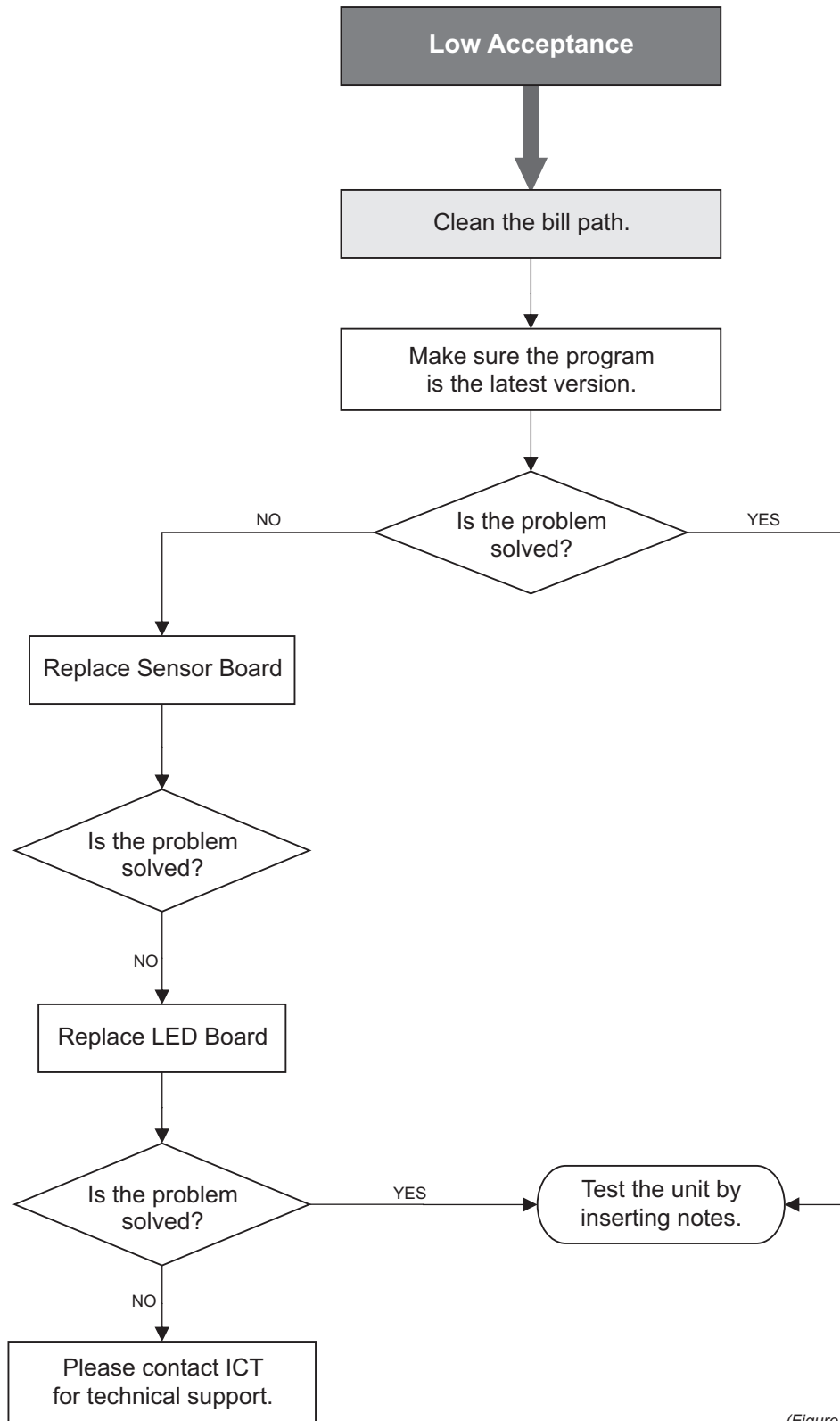

(Figure.73)

5-5. Wrong Credit Output

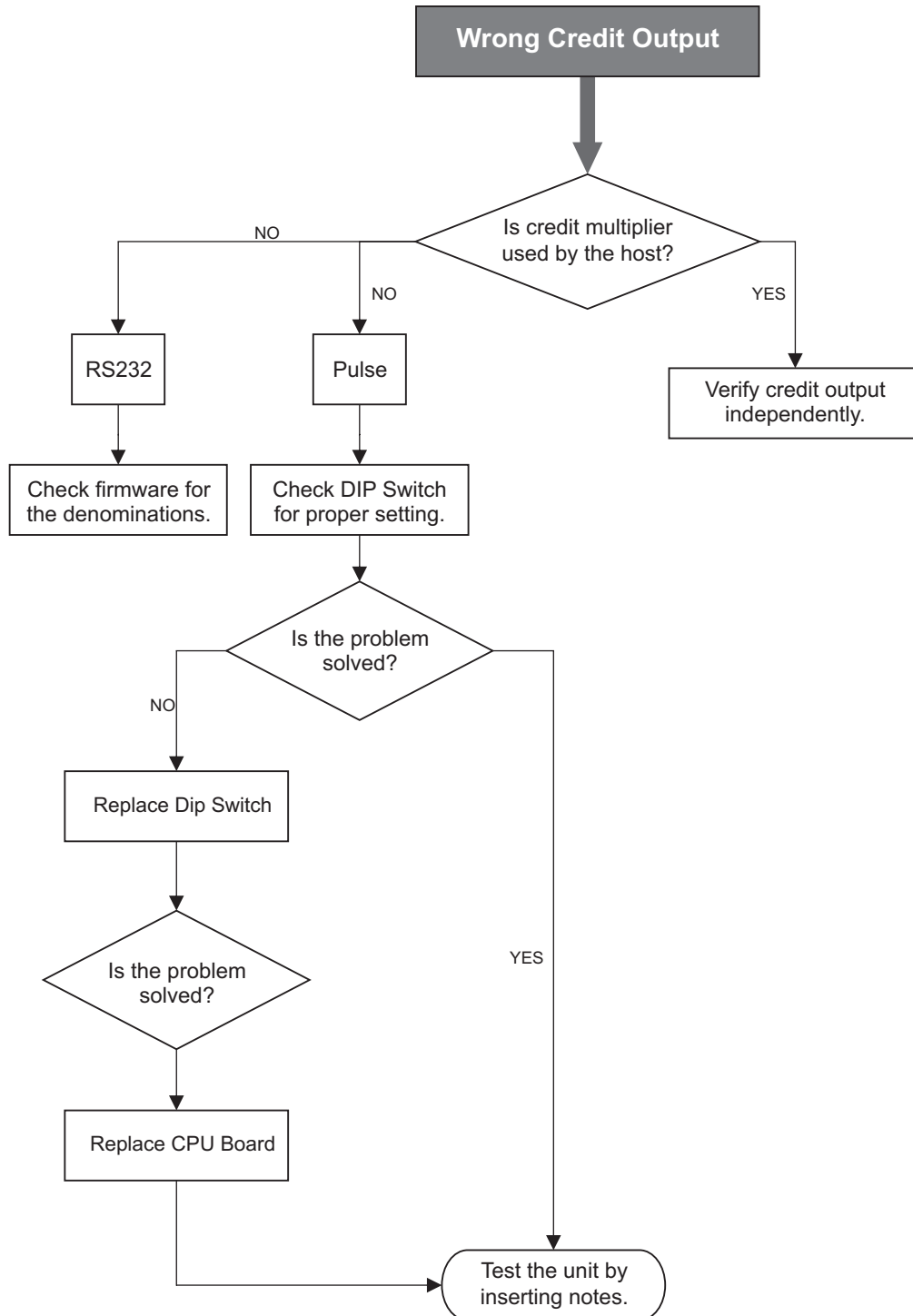

(Figure.74)

5-6. Motor with Strange Sound

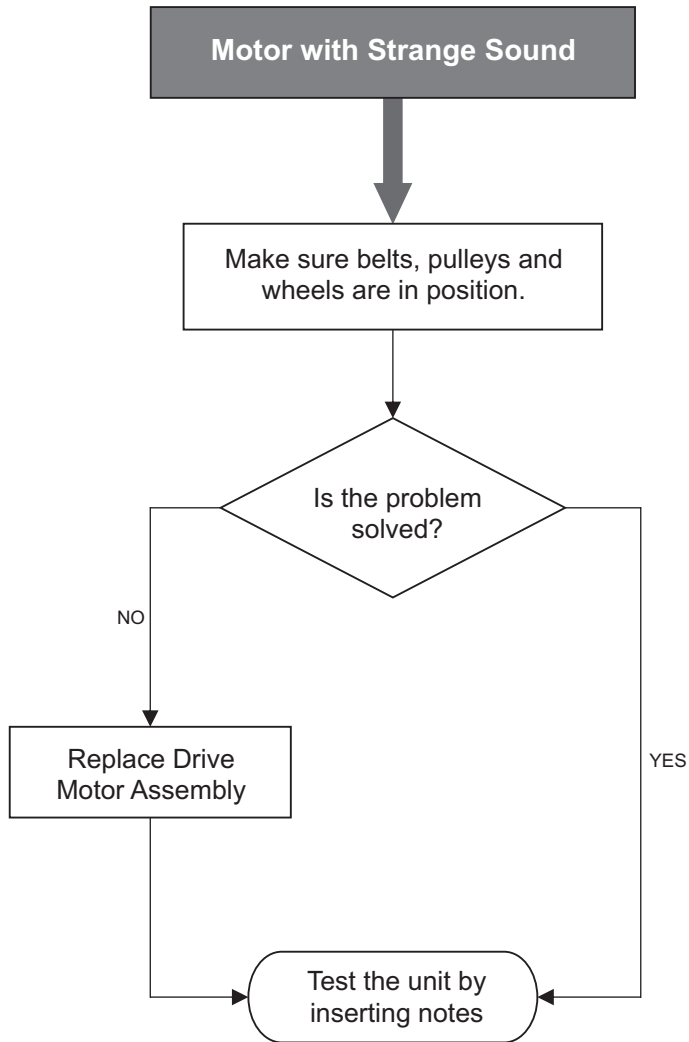

(Figure.75)

5-7. No Diagnostic LED Status

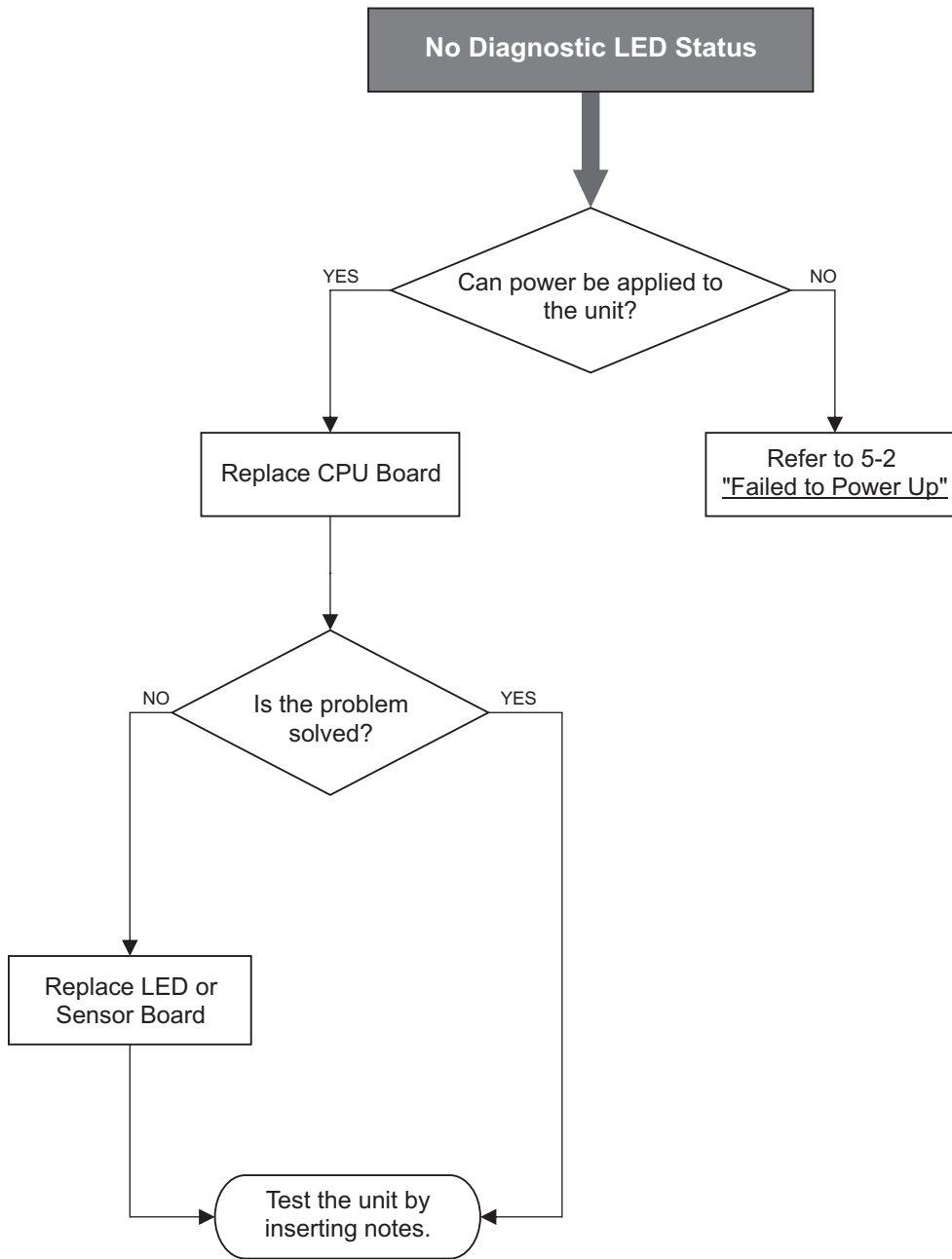

(Figure.76)

5-8. Bill Acceptor Error Code

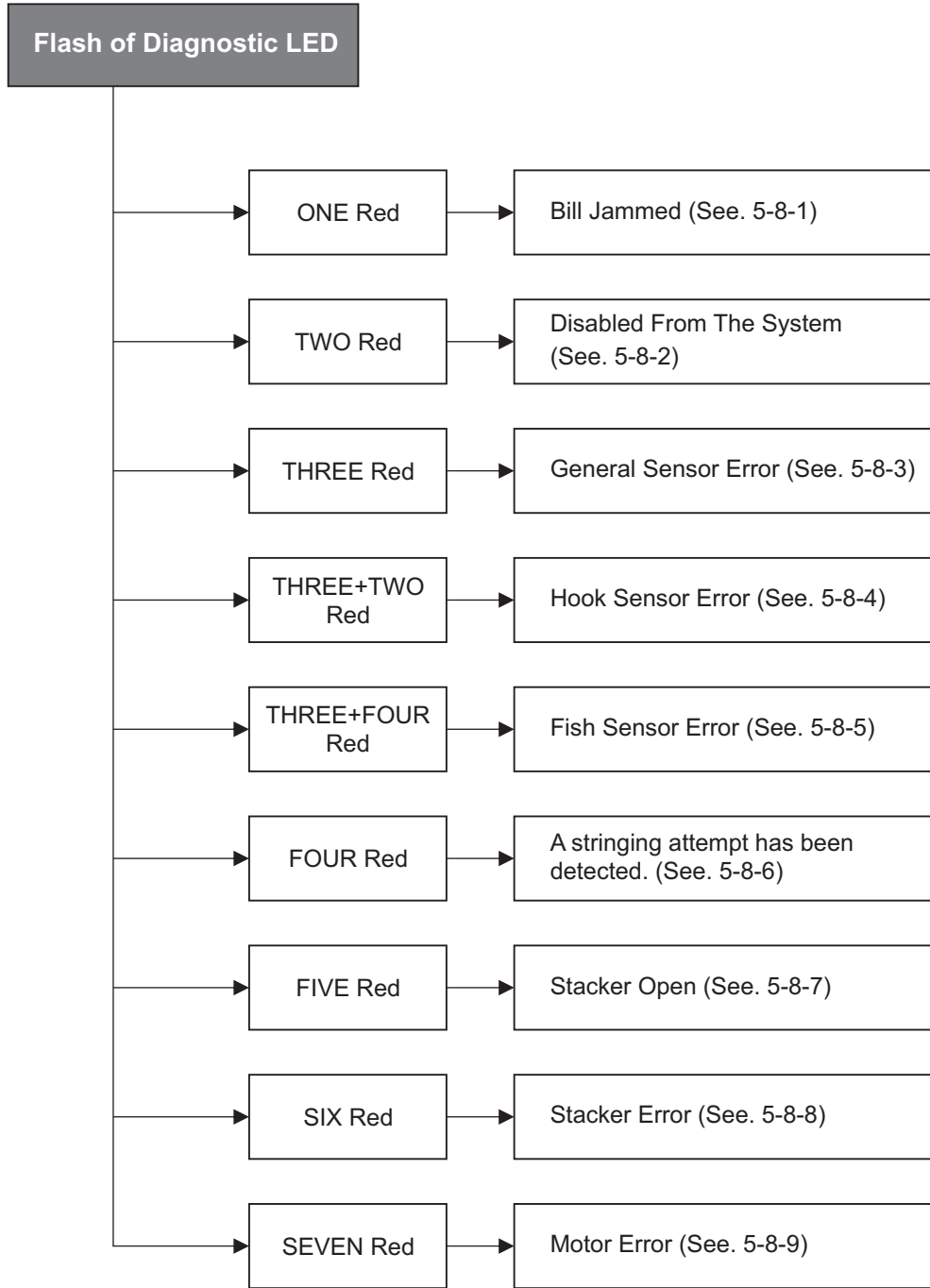

(Figure.77)

5-8-1. One Flash

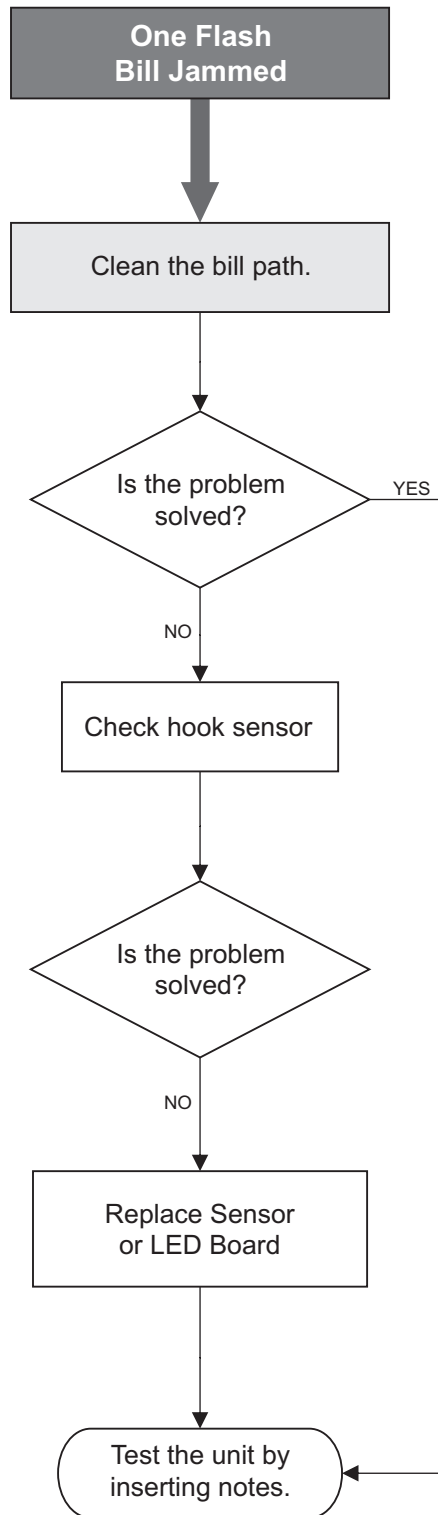

(Figure.78)

5-8-2. Two Flashes

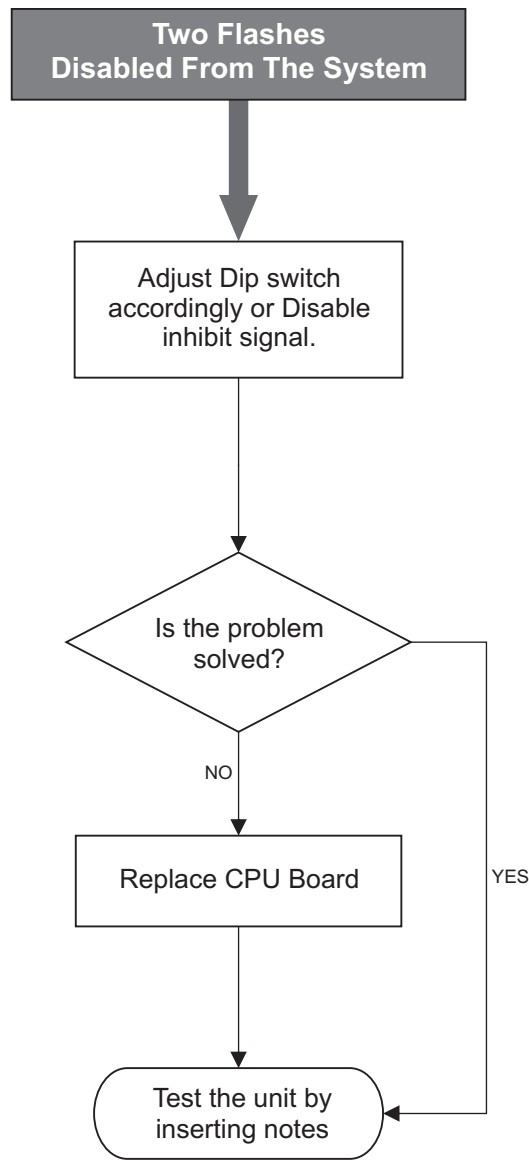

(Figure.79)

5-8-4. Three Flashes

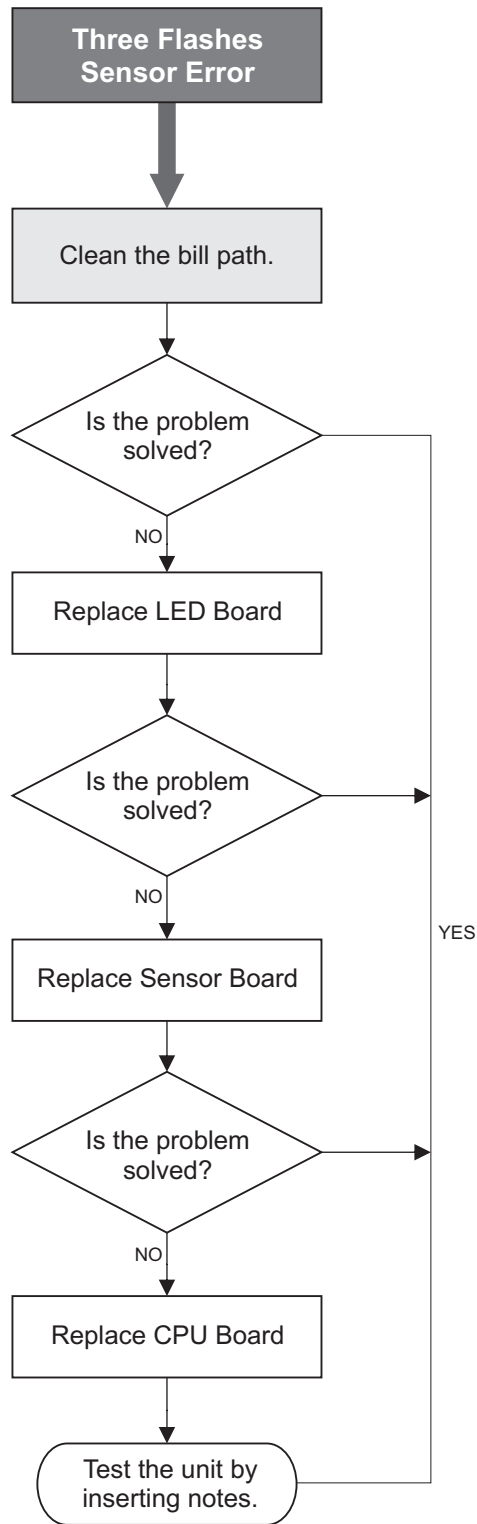

(Figure.80)

5-8-5. Three+Two Flashes

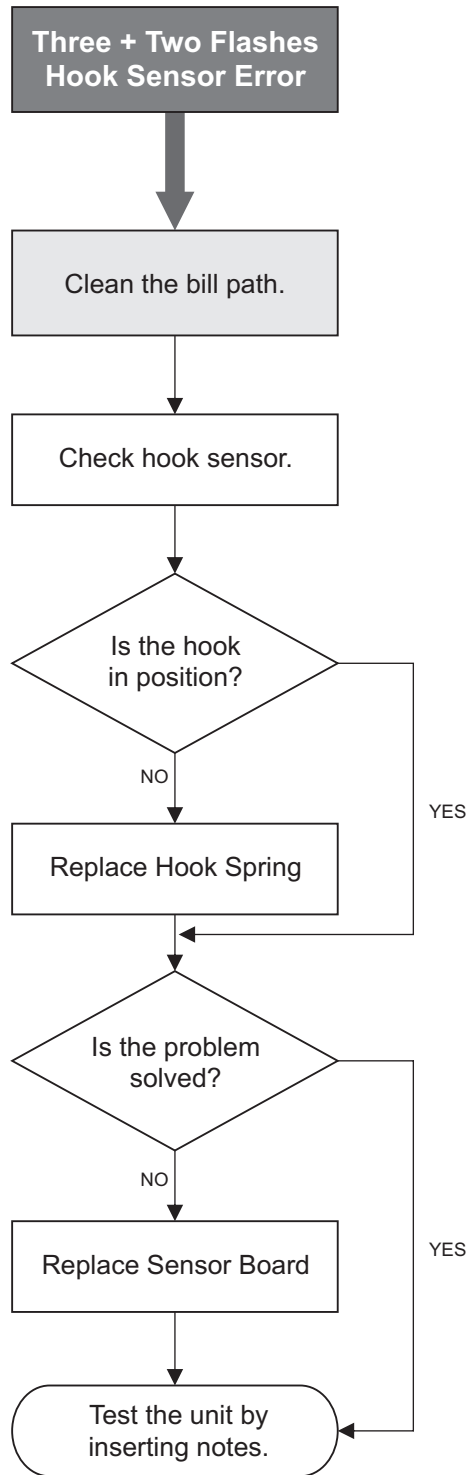

(Figure.81)

5-8-6. Three+Four Flashes

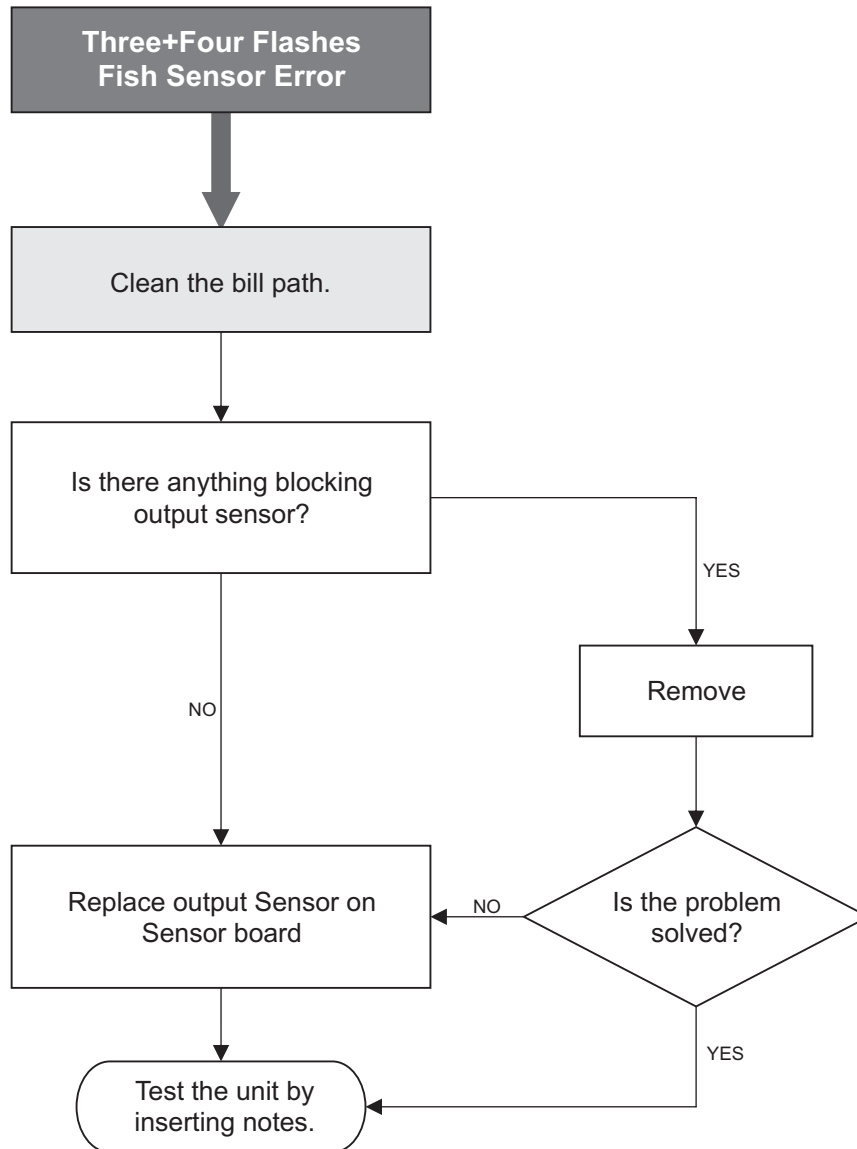

(Figure.82)

5-8-7. Four Flashes

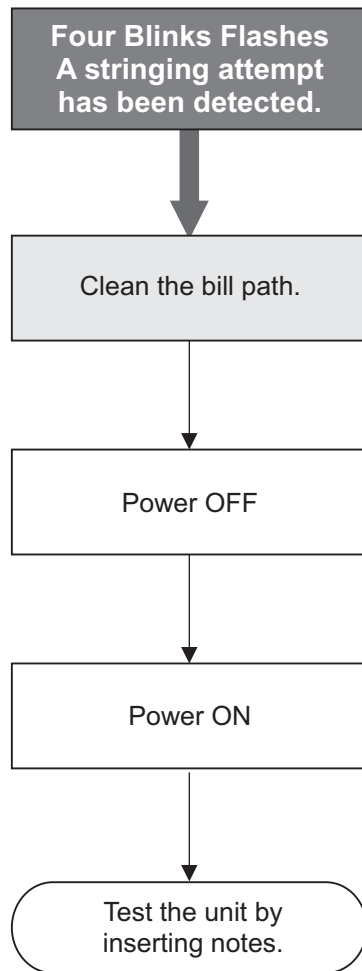

(Figure.83)

5-8-8. Five Flashes

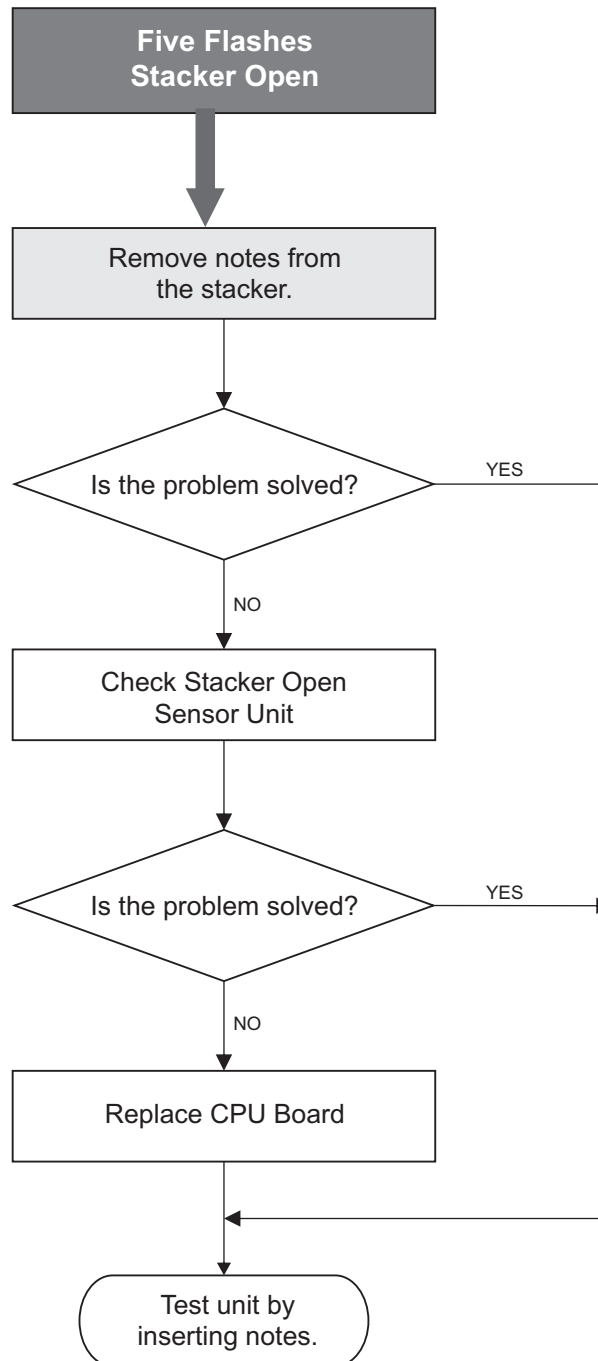

(Figure.84)

5-8-9. Six Flashes

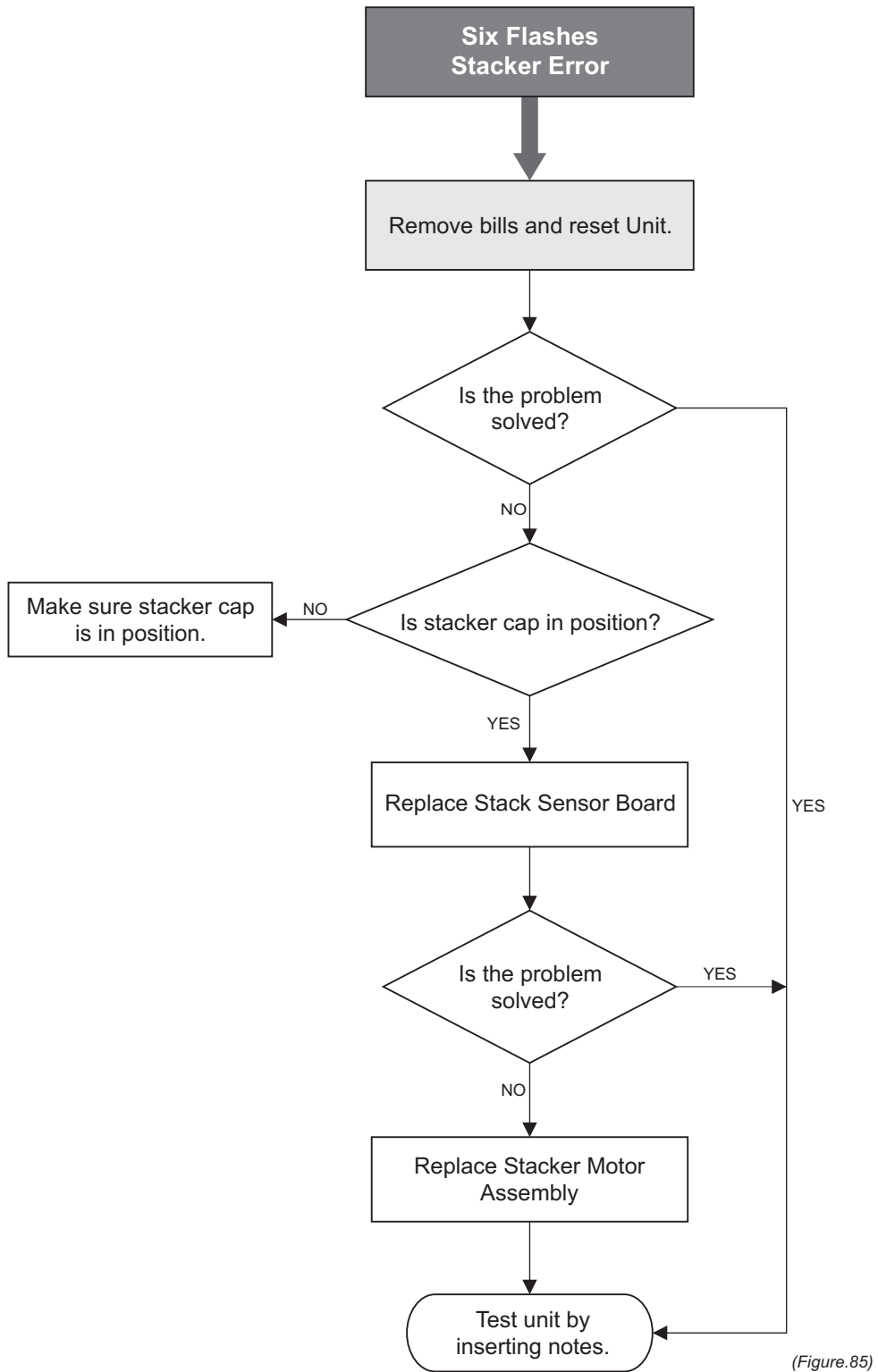

(Figure.85)

5-8-10. Seven Blinks

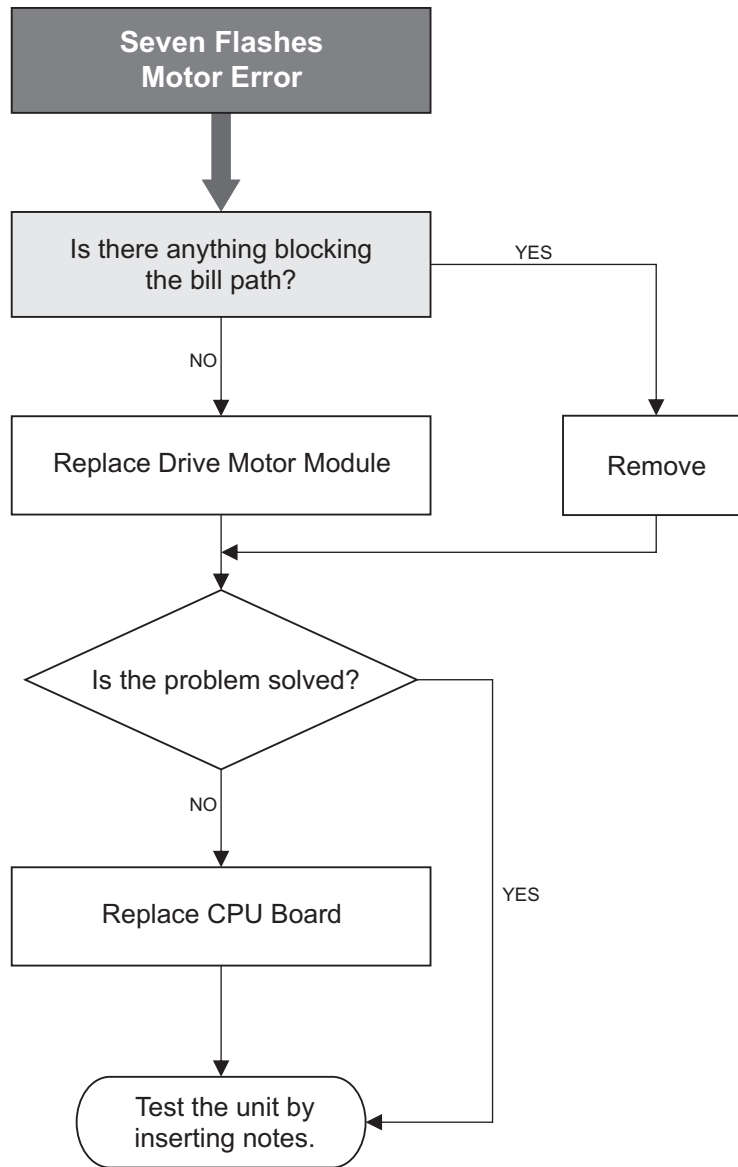

(Figure.86)

6. Parts and Assembly Views

6-1. Exploded Views

XBA Main Module

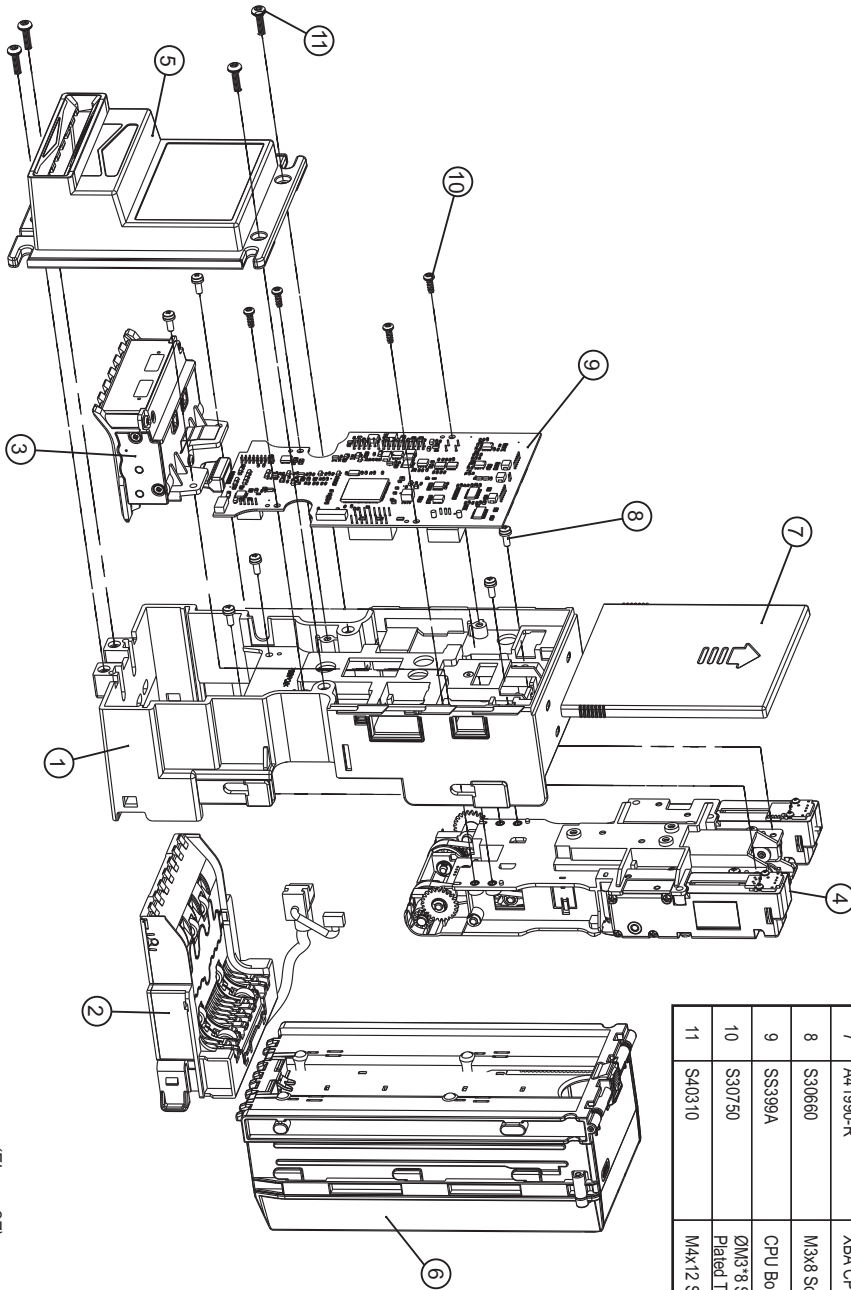

(Figure.87)

Order	Part number	Appellation	Quantity
1	3RMB-CAS18000	XBA Main Module	1
2	3RMB-UPX18001	XBA Upper Base Module	1
3	3RMB-DVWN24001	XBA Lower Base Module	1
4	3RMB-CAS17000	Stack Module	1
5	3RMB-FAC40000	Standard Bezel Unit	1
6	3RMB-SB X86000	200P Bill Box Module	1
7	A41990-R	XBA CPU Door	1
8	S30660	M3x8 Screw with washer	6
9	SS399A	CPU Board	1
10	S30750	ØM3*8 Self-tapping Screw Back Zinc Plated TP2	4
11	S40310	M4x12 Screw	4

(Table.2)

Upper Base Module

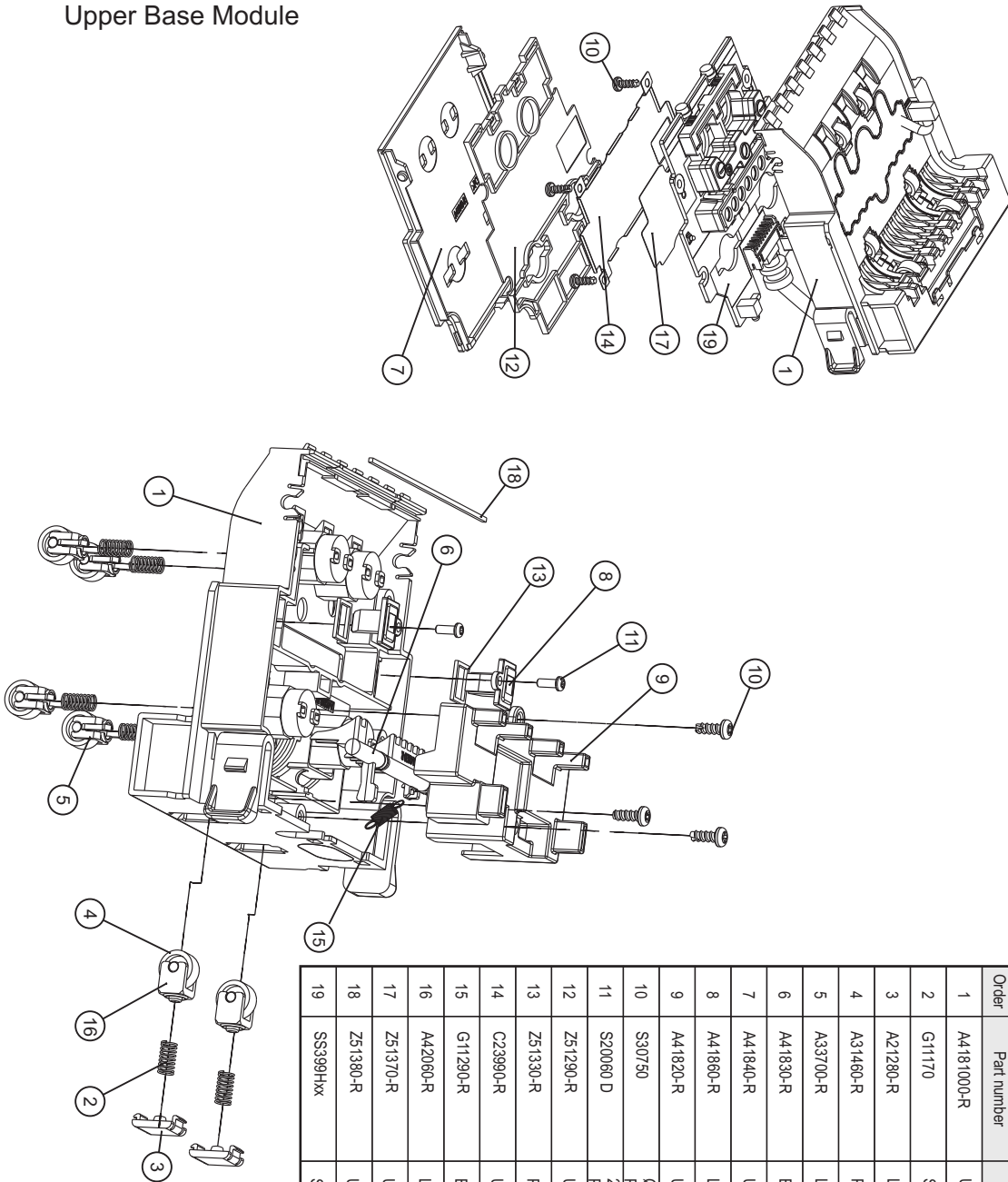

Order	Part number	Appellation	Quantity
1	A4181000-R	Upper Base Unit	1
2	G11170	Spring	6
3	A21280-R	Lidder Cover	2
4	A31460-R	Press Roller	6
5	A33700-R	Leiler Mount	4
6	A41830-R	Burglarproof	1
7	A41840-R	Upper Base Upper Cover	1
8	A41860-R	LED light guide prism	2
9	A41820-R	Upper Base Waterproof cover	1
10	S30750	Ø3*8 Self-tapping Screw Black Zinc Plated TP2	7
11	S20060 D	2.3X6 Self-tapping Screw Black Zinc Plated TP2	2
12	Z51290-R	Upper Base Dust Eraser	1
13	Z51330-R	Prism Dust Eraser	2
14	C23990-R	Upper Base Baffle Board	1
15	G11290-R	Burglarproof Hook Drawspring	1
16	A42060-R	Leiler Mount	2
17	Z51370-R	Upper Base Baffle Board Mylar	1
18	Z51380-R	Upper Base Waterproof Foam	1
19	SS399Hxx	Sensor Board	1

(Table-3)

(Figure-88)

Lower Base Module

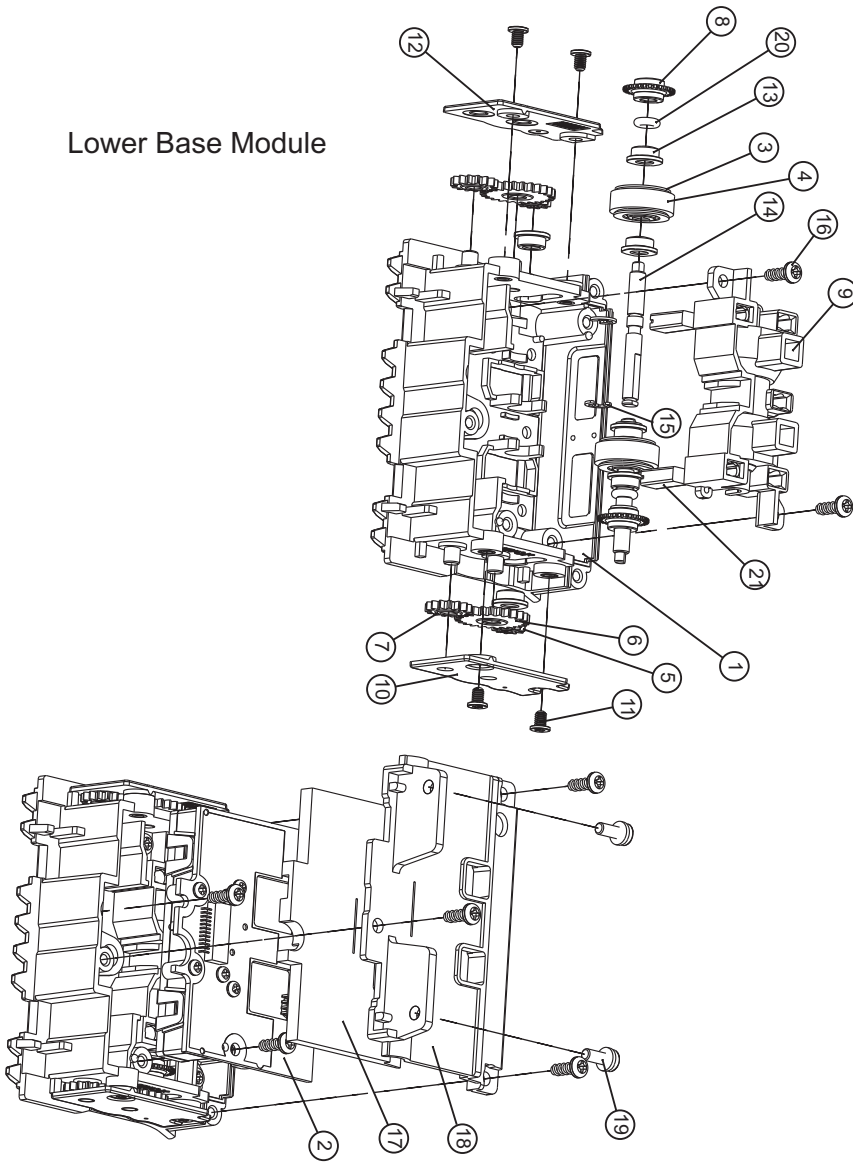

(Figure: 89)

Order	Part number	Appellation	Quantity
1	A4189000-R	Lower base Module	1
2	SS399Gxx	LED Board	1
3	A42070-R	Roller D Type	2
4	Z51310-R	Lower Base Water Proof Rubber	2
5	F11250-R	D Type Gear(M0.7xT10xW2)	2
6	F10880-R	O Type Gear (M0.7x T25xW2)	2
7	F10940-R	O Type Gear (M0.7x T15xW2)	2
8	A41960-R	Optical Shutter (30P)	2
9	A41910-R	Lower Base Waterproof cover	1
10	A41940-R	Lower Base Gear Cover Plate (Right)	1
11	S31240	M3x4 I Type Screw Black Zinc Plated	4
12	A41950-R	Lower Base Gear Cover Plate (Left)	1
13	A35390-R	Plastic Axle Bush	6
14	B15130-R	Front Roller Axle	2
15	S10020	E3-E Type Ring	4
16	S30750	Ø3*8 Self-tapping Screw Black Zinc Plated TP2	8
17	Z51300-R	Lower Base Water Proof Rubber	1
18	A41900-R	Lower Base Cover	1
19	S30660	M3*8 Screw with washer	2
20	Z51320-R	O ring (P3)	2
21	A41970-R	Waterproof cover light guide	2

(Table-4)

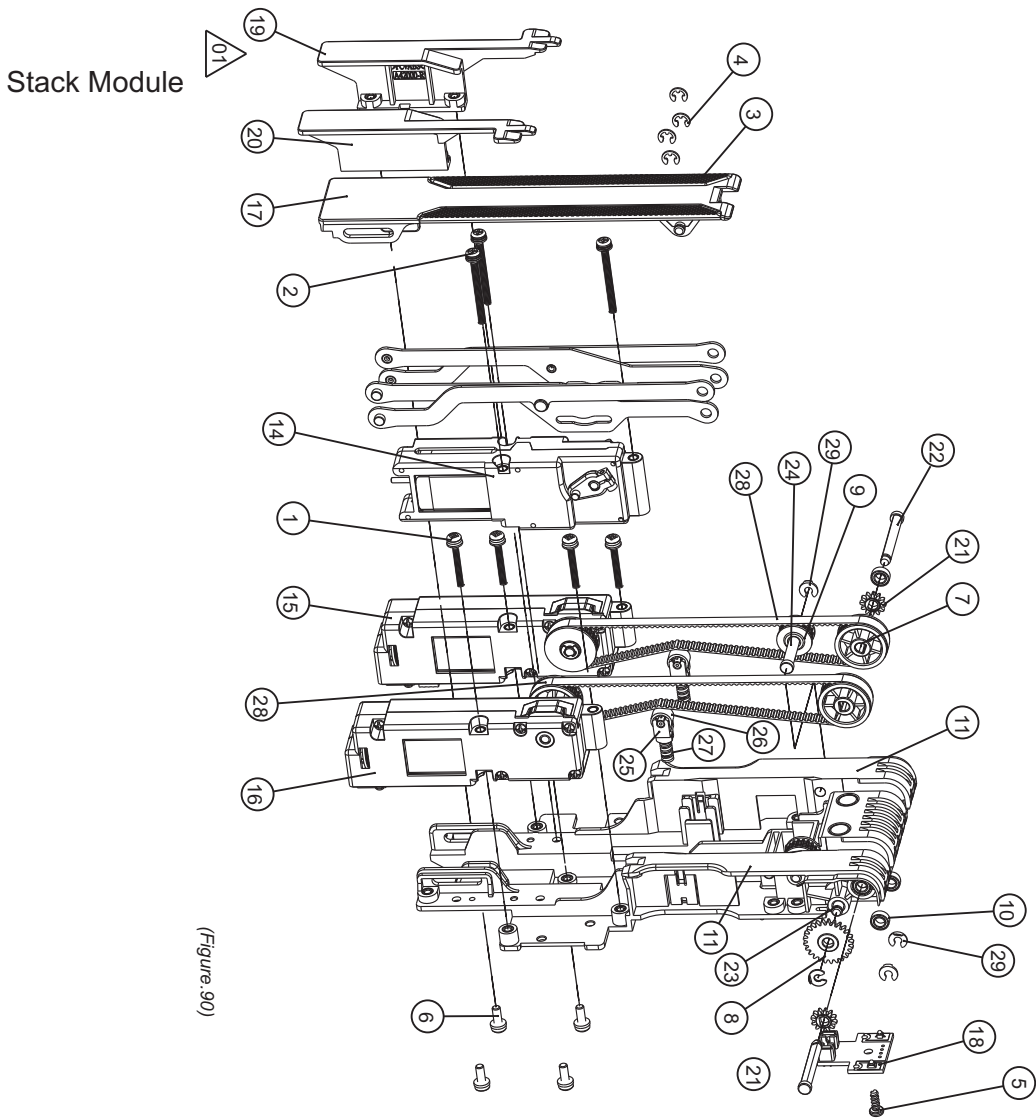

(Figure.90)

(Table.5)

Order	Part number	Appellation	Quantity
1	S31430	M3x20 Round Head Screw with washer	4
2	S31700	M3x30 Round Head Screw with washer	3
3	Z50530-R	Anti-skid Rubber	2
4	S10020	E3-E Type Ring	4
5	S30750	Ø3.8 Self-tapping Screw Black Zinc Plated TP2	1
6	S30660	M3x8 Screw with washer	4
7	A20740-R	Belt Roller-T30 Type D	2
8	F10880-R	O Type Gear (M0.7x T25xW2)	2
9	A29850-R	Belt Roller-T20 Type O	2
10	J11140-R	Bearings-740ZZ(D7x4x12.5)	4
11	A4198000-R	Bill Stacking Structure Pedestal	1
12	C2397000-R	Right Scissors Unit	1
13	C2398000-R	Left Scissors Unit	1
14	3RMB-MOT2.1000	Stacker Motor	1
15	3RMB-MOT20000	Bill Sending Motor Set (Right)	1
16	3RMB-MOT22000	Bill Sending Motor Set (Left)	1
17	A42020-R	Stacker Board	1
18	SS399Fxx	Cash Box Sensor Board	1
19	A42000-R	Block structure Rails R	1
20	A42010-R	Block structure Rails L	1
21	F12020-R	Spur Gears(M0.7X12T-D type)	2
22	B15160-R	Belt Axle Type D (30)	2
23	B15140-R	Belt Axle Type D (25T)	2
24	B15150-R	Belt Axle (20T)	2
25	A42050-R	Leter Mount	2
26	A42040-R	Press Roller	2
27	G11170	Spring	2
28	E50460-R	Belt (140MxL-4.8W)	2
29	A42250-R	Plastic E3-E Type Ring(3mm)	6

Bill Box Module (200P)

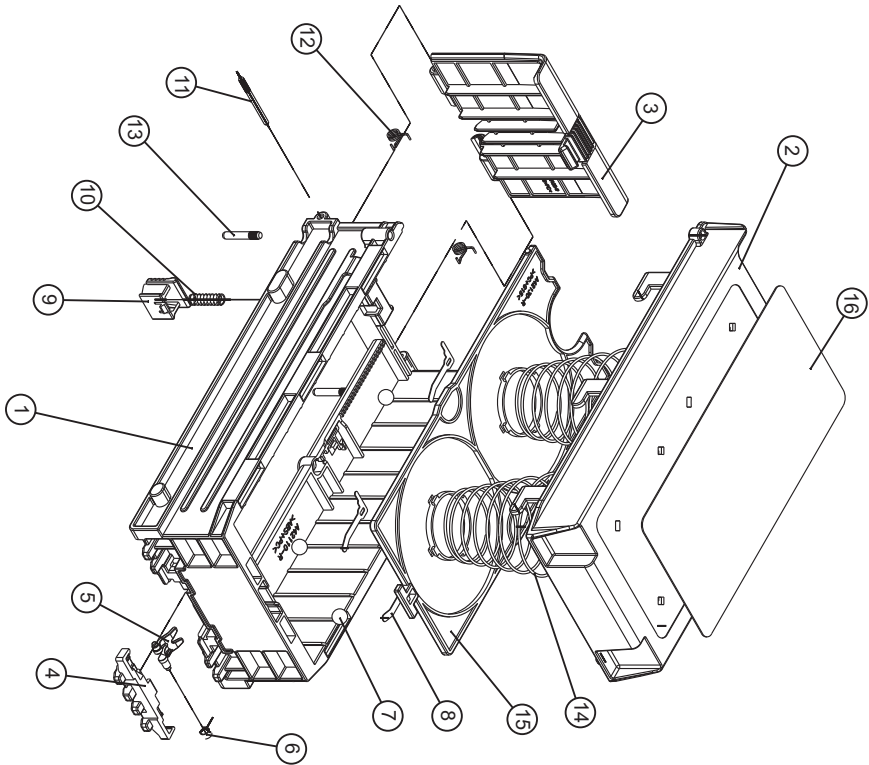

(Figure. 91)

Order	Part number	Appellation	Quantity
1	A42110-R	Bottom Base Module of Bill Box	1
2	A42100-R	Bill Box Top Cover	1
3	A42120-R	Bill Box Door Plate	1
4	A42180-R	Positioned lens	1
5	A42170-R	Bill Pressed Board	1
6	G111580-R	Tensional Spring of Bill Pressed Board (0.3x3.0x10T)	1
7	J11160-R	1/4" Nylon Ball	4
8	C20280-R	Pick	5
9	A2202A-R	Slider	1
10	G1038A-R	Spring	1
11	B10860-R	Door Link	2
12	G12040-R	Tensional Spring of Door Link	2
13	B13600-R	Door Link Spindle	2
14	G11130-R	Vortex Spring	2
15	A42130-R	Bills Supporting Board	1
16		Bill Box Sticker 140 x 67 mm	1

(Table. 6)

Bill Box Module (400P)

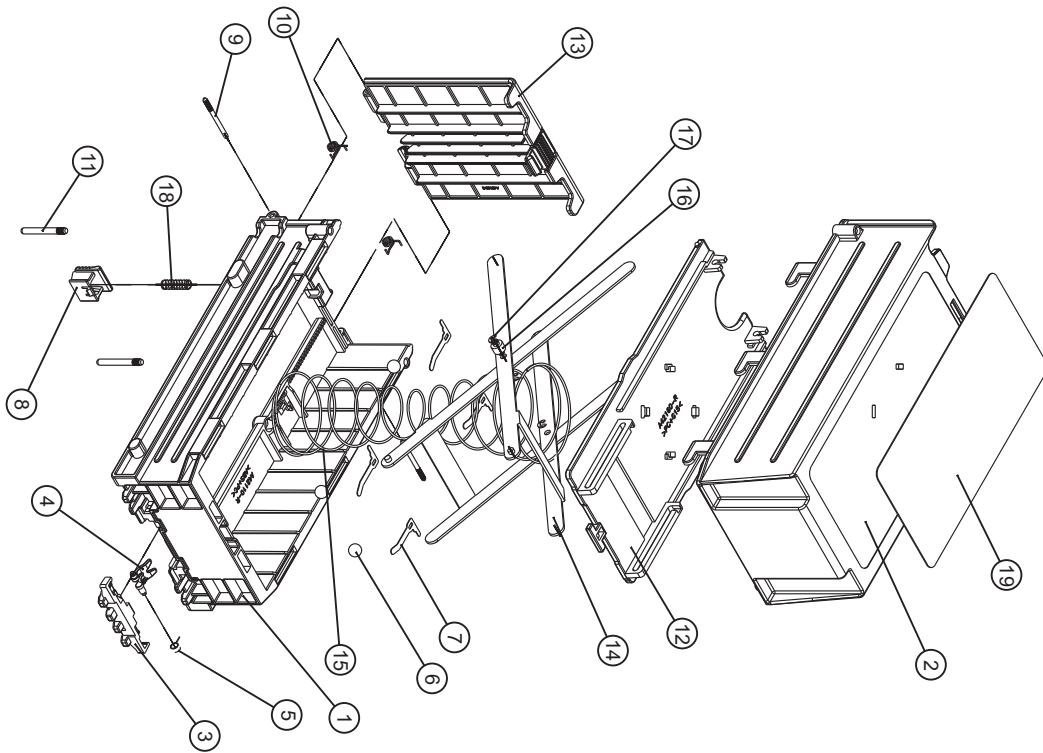

(Figure: 92)

Order	Part number	Appellation	Quantity
1	A42110-R	Bottom Base Module of Bill Box	1
2	A42140-R	Bill Box Top Cover	1
3	A42180-R	Positioned lens	1
4	A42170-R	Bill Pressed Board	1
5	G11580-R (0.3x3.0x10T)	Tensional Spring of Bill Pressed Board	1
6	J11160-R	1/4" Nylon Ball	4
7	C20280-R	Pick	4
8	A2202A-R	Slider	1
9	B10860-R	Door Link	2
10	G12040-R	Tensional Spring of Door Link	2
11	B14500-R	Door Link Spindle	2
12	A42160-R	Bills Supporting Board	1
13	A42150-R	Bill Box Door Plate	1
14	C23760-R	Scissors	2
15	G12710-R	Vortex Spring	1
16	B15060-R	Scissors Spindle	2
17	S10010	E2-E Type Ring	4
18	G1038A-R	Spring	1
19		Bill Box Sticker 140 x 67 mm	1

(Table: 7)

6-2. Circuit Board Overviews

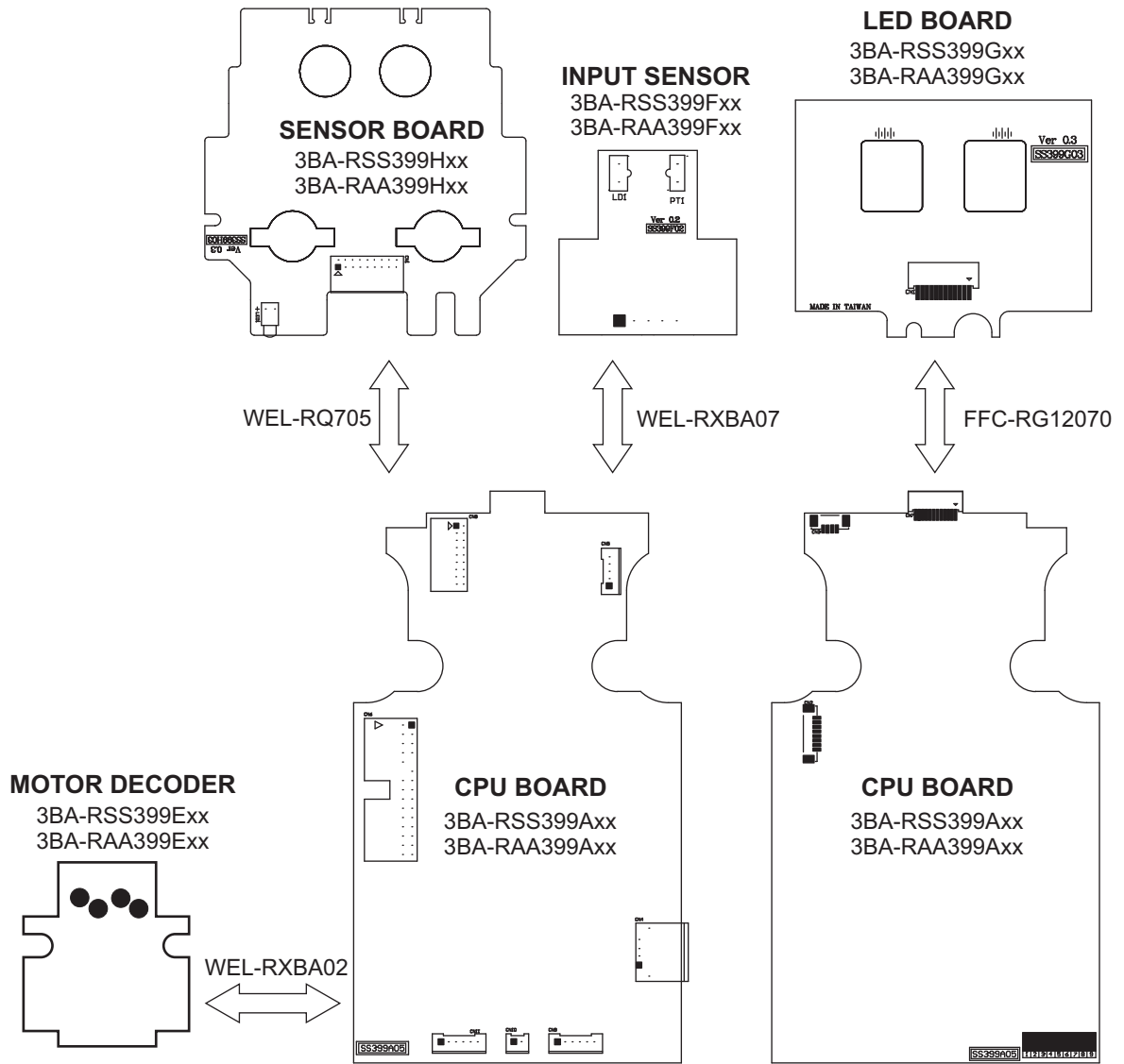

(Figure.93)

7. Model Number Configuration

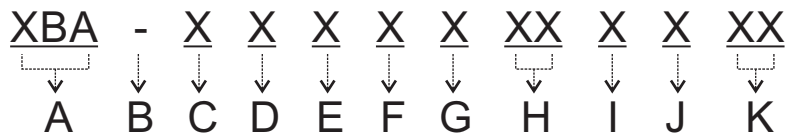

A: Model

B: Retention code

C: Voltage

D: Bill Box Capacity

E: Bezel

F: Coating method

G: Interface

H: Currency

I: Denominations

J: Customer

K: Software Version

(A): Mode

Code	Model
XBA	XBA Series

(Table.8)

(B): Retention code

Code	
-	Retention code

(Table.9)

(C): Voltage

Code	Voltage
1	DC 12V
2	DC 24V
3	DC 34V
4	AC 24V / DC 34V

(Table.10)

(D): Bill Box Capacity

Code	Bill Box Capacity
2	200 Bills
4	400 Bills

(Table.11)

(E): Bezel

Code	Bezel
D	Standard Bezel (Two-Sided)
T	T-Bezel

(Table.12)

(F): Coating method

Code	Coating method
P	PVD
N	Non-PVD

(Table.13)

(G): Interface

Code	Interface
M	MDB
P	Pulse
R	ICT002

(Table.14)

(H): Currency : EU. Euro

(I): Denominations

Code	Denominations
1	1 Denomination
2	2 Denominations
3	3 Denominations
4	4 Denominations
5	5 Denominations
6	6 Denominations
7	4 Denominations

(Table.15)

(J): Customer

Code	Customer

(Table.16)

(K): Software Version : 00~99

ict Taiwan

International Currency Technologies Corporation

Ji-Hong Building, No 24, Alley 38, Lane 91, Nei-hu Rd., Sec. 1, Taipei, Taiwan, R.O.C.

Tel: 886-2-2797-1238 · Fax: 886-2-2797-1634

sales@ictgroup.com.tw (For Sales) · rma@ictgroup.com.tw (For Customer Service)

Website: www.ictgroup.com.tw



www.ictgroup.com.tw